

TRAILER

Hot Water - Diesel or Gas Powered - Diesel/Oil Heated

LANDA®

Operator's Manual

MODELS: TR-6000
1.103-804.0

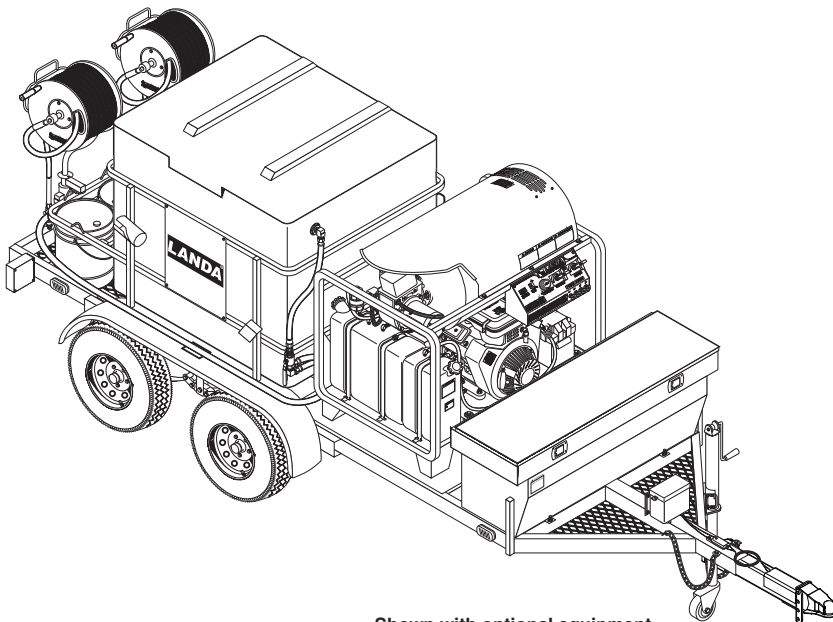

Shown with optional equipment

For the Landa Dealer nearest you, consult our web page at www.Landa.com

SHOP PRESSURE WASHER PARTS
shoppressurewasherparts.com | (888) 269-0172



8.913-956.0-T 10/18/21

Machine Data Label

Model Number _____

Serial Number _____

Date of Purchase _____

The model and serial numbers will be found on a decal attached to the machine. You should record both serial number and date of purchase and keep in a safe place for future reference.

Introduction

Thank you for purchasing this Pressure Washer. We reserve the right to make changes at any time without incurring any obligation.

Owner/User Responsibility:

The owner and/or user must have an understanding of the manufacturer's operating instructions and warnings before using this pressure washer. Warning information should be emphasized and understood. If the operator is not fluent in English, the manufacturer's instructions and warnings shall be read to and discussed with the operator in the operator's native language by the purchaser/owner, making sure that the operator comprehends its contents. Owner and/or user must study and maintain for future reference the manufacturers' instructions.

Save These Instructions

This manual should be considered a permanent part of the machine and should remain with it if machine is resold. When ordering parts, please specify model and serial number. Use only identical replacement parts. This machine is to be used only by trained operators.

Notice

This trailer is equipped to meet applicable U.S. Federal safety standards. Check local and state requirements regarding brakes and any additional equipment that may be required. Any modifications or additions including load-equalizing hitches, without written factory consent: usage in an abnormal manner including overloading voids all manufacturers' warranties and liability.

WARNING: This Owner's Manual contains safety information and instructions for your trailer. You must read this manual before loading or towing your trailer. You must follow all safety precautions and instructions.

AVERTISSEMENT: Ce manuel de l'utilisateur contient des informations en matière de sécurité et des instructions pour la remorque. Lire le présent manuel avant de charger ou de remorquer la remorque. Suivre toutes les précautions de sécurité et les directives.

Machine Data Label 2
Introduction 2
Table of Contents 3

Important Trailer Safety Information

Referencing the Utility Trailer in this Manual 4
Tire Safety 4
Basic Tire Maintenance 4
Identifying Your Recommended Tire Pressure and
Maximum Load Carrying Capacity for Your Trailer .
4
Understanding Tire Pressure and Load Limits 4
Tire Size 5
Safety Tips 5
Never Tow the Trailer Before Checking: 5
Tow Vehicles 5
Trailer Ball & Couplers 6
Before Towing: 6
Variable Height Bracket: 6
Bolting Instructions: 6
Maintenance 6
Hitch Coupler Troubleshooting 7
Coupler & Ball Engagement 7
Safety Chains 7
Load-Carrying Capacity 8

What To Check And How To Check

Proper Weight Distribution & Tongue Weight 9
Tongue Weight 9
Tire Pressure 9
Wheels 9
Wheel Lugs 9
Wheel Torque Requirements 9
Ball Coupler Hitches 10
Tires 10
Breakaway Switch & D.O.T. Wet Cell Battery 11
Breakaway Switch Mounted on an A-Frame 11
Check Breakaway System & Brakes Before Each Trip
11
Brakes 11
Burnishing the Brakes 11
Reporting Safety Defects 11

Maintenance

Preventative Maintenance 12

Parts

TR-6000 14
TR-6000 PGHW 18
Trailer Options & Accessories 22
Wiring Diagram 24

Important Trailer Safety Information

Referencing the Utility Trailer in this Manual

All references to the trailer or component parts to either left or right are made with the assumption that you are standing behind the trailer facing forward. Your left hand or right hand is the equivalent on the trailer.

Tire Safety

The most common cause of trailer tire failure is under-inflation. Therefore, it is important that you always maintain the specified air pressure as indicated by the tire manufacturer on the tire's side-walls. This information can also be found on the tire label or the air pressure molded on the tire side-wall.

The most important things you can do to maintaining proper tire pressure are observe all tire and trailer maximum carrying capacities, avoid road hazards, and inspect the tires for cuts, slashes and other irregularities. These practices, along with other care and maintenance, can improve handling, help protect you and others from avoidable breakdowns and accidents, improve fuel economy, and increase the life of your tires.

Make tire safety a regular part of your trailer maintenance routine. The time you spend is minimal compared to the amount of time, inconvenience, and potential safety hazards that can occur from a flat tire or failure.

Basic Tire Maintenance

Properly maintained tires improve the load-carrying capability of your trailer. You can help avoid flat tires and tire failures by maintaining proper tire pressure, observing tire and trailer capacity limits, avoiding road hazards, and inspecting your tires regularly.

Identifying Your Recommended Tire Pressure and Maximum Load Carrying Capacity for Your Trailer

Both the tire placard and the VIN label are permanently attached on top of the frame of your trailer and have the required information printed on them. They also list the maximum load that can be placed on the trailer without exceeding the load limits of the tires or the trailers other components. These labels indicate the manufacturer's information including:

- Recommended tire size.
- Recommended tire inflation pressure.
- The maximum weight the trailer is designed to carry.
- Gross vehicle weight rating of the trailer.
- Gross axle weight rating of the trailer.

Understanding Tire Pressure and Load Limits

Tire inflation pressure is the level of air in the tire that provides it with the load-carrying capacity and affects the overall performance of the trailer. The tire inflation pressure is a number that indicates the amount of air pressure that is inside the tire. It is measured in pounds per square inch (PSI). The tire must be inflated to the air pressure as designated on the labels. Also listed on the labels is the air pressure in kilo Pascals (kPa), which is a metric measurement. Tire manufacturers determine the air pressure to maximize the amount of weight the tires can safely carry. The proper tire pressure for your trailer tires is referred to as the "recommended cold inflation pressure." It is difficult to obtain the recommended tire pressure if your tires are not cold when the reading is taken because the air will expand when it is warmed by towing down the road, thus increasing the air pressure inside. If air is added to a tire that is low the air pressure should never exceed the recommended pressure.

It is important to check your trailer's tire pressure at least once a month for the following reasons:

Most tires will naturally lose air over time.

Tires can lose air suddenly if driven over an object that punctures or cuts the tire. Sometimes a sharp blow from a pothole or curb can knock the tire loose from the rim causing immediate deflation.

Maintaining Proper Tire Pressure

Locate the recommended tire pressure on the trailer's tire information placard or owner's manual.

Record the tire pressure of all tires. If the tire pressure is too high in any of the tires, slowly release air by gently pressing on the tire valve stem with the edge of your tire gauge until you get the correct pressure.

If the tire pressure is too low, note the difference between the measured tire pressure and the correct tire pressure. These "missing" pounds of pressure are what you will need to add.

Add the missing pounds of air pressure to each tire that is under inflated.

Check all tires to make sure they have the same air pressure.

If you have been towing your trailer and think that a tire is under inflated, fill it to the recommended cold inflation pressure indicated on your trailer's tire label placard or the VIN label. You can also check the sidewall of the tire for a correct tire inflation pressure. Your tire will have a slightly lower air pressure because the tire is warm when you are inflating it, but it will be much better than to continue to tow it with the under inflation it may have had.

Once the trailer has been parked long enough to allow the tires to cool down, recheck the tire pressure and add additional air to return the tire pressure to the recommended level.

Tire Size

To maintain the trailer's carrying capacity and safety, purchase only the same size tires as what were originally supplied on the trailer.

Safety Tips

Slow down if you have to go over a pothole or other object in road.

Do not run over curbs and try not to strike the curb when parking.

For a free brochure visit:

www.nhtsa.dot.gov

IMPORTANT: Before towing this trailer be sure to read the instructions and warnings supplied in this manual. Also read the information supplied with your tow vehicle so you know and understand its limitations.

Never Tow the Trailer Before Checking:

- Coupler and latch assembly show no signs of wear or damage.
- Coupler hitch and hitch ball are of the same size.
- Coupler and safety chains are safely secured to the hitch.
- Check all fasteners for proper tightness.
- Load is securely tied down to the trailer.
- Wheel lug nuts are properly tightened to the right torque.
- Wheel bearings are properly adjusted and maintained.
- Load is within the maximum load carrying capacity of trailer.
- Tires are properly inflated and are road worthy.
- All trailer lighting is working properly.
- Tire pressure and tire condition
- Wheel lugs*
- Bearing lube and tightness
- Hitch
- Safety chains
- 12V running lights
- Distribution and security
- Caster up in travel position

* Check lug nuts for tightness before initial trip, at 10 miles, 25 miles and 50 miles. Recheck every 3 months or 3000 miles.

NOTE: Checking all of the above steps before every trip is key for safety.

IMPORTANT: The load must be distributed equally on the bed of the trailer if possible. Heavy, concentrated loads may cause damage or possible failure of the trailer.

WARNING: Loads placed on the trailer must be securely tied to the trailer. Always use appropriate tie downs designed to restrict loads from moving when properly attached. Failure to do so will allow shifting of the load causing potential trailer failure and/or loss of the load and personal injury.

AVERTISSEMENT: Les charges placées sur la remorque doivent être solidement attachées à la remorque. Toujours utiliser des arrimages appropriés conçus pour empêcher les charges de bouger lorsqu'elles sont bien attachées. Le non-respect de cette consigne permettra le mouvement de la charge, entraînant une défaillance potentielle de la remorque et/ou une perte de la charge et des lésions corporelles.

This trailer is equipped to meet all applicable federal safety standards in effect the day of manufacture. Check local and state requirements regarding any additional equipment that may be required.

The addition of optional equipment to your trailer may increase the total weight of your trailer package to where it now exceeds the maximum load carrying capacity of the trailer.

Tow Vehicles

WARNING: Serious injury or property damage can result if the total weight of your loaded trailer exceeds the capacity of the hitch and/or your tow vehicle.

AVERTISSEMENT: Des blessures graves ou de dommages à la propriété peuvent survenir si le poids total de la remorque chargée excède la capacité de l'attelage et/ou du véhicule remorqueur.

It is very important that you know and understand the towing capabilities of your tow vehicle. This is especially true with the braking abilities of the tow vehicle. You should check with your authorized dealer to see what the capabilities are for the total towing load and the maximum allowable tongue weight for the vehicle you plan on using for towing.

It is also important that the lighting system in the tow vehicle has sufficient capacity support the additional load the trailer lighting will add to the system. A heavy duty flasher may be required to make your turn signals function properly.

Important Trailer Safety Information

Trailer Ball & Couplers

WARNING: Failure to properly engage the hitch ball in the coupler ball socket and securely lock the coupler latch mechanism can cause the trailer to become detached from the tow vehicle while traveling, which may cause serious injury or property damage.

AVERTISSEMENT: Le non-respect d'engager correctement la boule d'attache dans la cavité de la boule de l'attelage et de verrouiller solidement le mécanisme du loquet de l'attelage pourrait mener la remorque à se détacher du véhicule remorqueur pendant le déplacement, ce qui pourrait causer des blessures graves ou des dommages à la propriété.

Ball diameter for which rating (GVWR) shall not exceed the gross trailer weight marked on the trailer coupler.

The hitch balls have the rated load they are capable of towing stamped into the top of the ball.

Make sure the ball that you use to tow your trailer has the same capacity rating as the coupler.

Do not use a different size ball than the size the coupler is designed to use.

Class	Coupler	Ball Diameter
II	3,500# GVWR	2"
III	5,000# GVWR	2"
IV	8,000# GVWR	2 5/16"

Before Towing:

Check mounting bracket hardware for wear and proper tightness. Replace bent, broken, or worn hardware. Tighten hardware to 75-94 ft. lbs. Use only the hardware provided with the Trailer. If replacement hardware is needed, order replacement kit 8.924-356.0.

Make sure that the trailer safety chains are properly connected to the towing vehicle and trailer according to SAE J684. See Safety Chain information in your manual.

Make sure that all trailer lighting is hooked up and working properly.

Warning: Failure to follow all installation instructions could result in coupler failure.

AVERTISSEMENT: Le non-respect de toutes les directives d'installation pourrait entraîner une panne du coupleur.

Variable Height Bracket:

Coupler operation must not be impaired in any way. Do not use if coupler operation is impaired.

Bolting Instructions:

Align holes in coupler and mounting bracket. NOTE: Coupler must be secured to mounting bracket using two sets of holes in the mounting bracket. Insert two (2) 5/8"x4.5", grade 5 bolts through desired mounting bracket holes and coupler. For each bolt, Place one (1) washer at the bolt head side and another at the bolt thread side before assembling the nuts. Tighten lock nuts to 90-96 ft. lbs. After installation, ensure coupler operation is not impaired in any way. Do not use if coupler operation is impaired. The hardware provided with the trailer has a self-lubricating coating which is taken into account for the tightening torque above, and is lower than standard hardware and also is more consistent with re-torque specifications to first-torque than standard hardware. Order replacements with the 8.924-356.0 replacement kit, or consult your hardware vendor for applicable, higher, torques for the application.

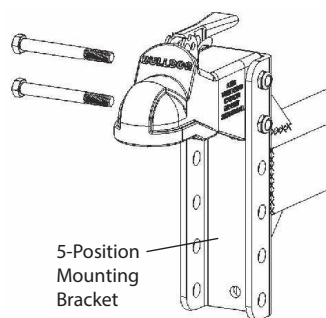

Maintenance

Keep ball pocket and mechanism clean. The following procedures should be performed at least annually:

Check set screw torque Grease ball pocket

Oil pivot points with SAE 30 wt. motor oil

Inspect retaining pin and replace if necessary

Operation

To Couple:

1. Block trailer wheels.
2. Align hitch ball beneath coupler.
3. Open coupler locking lever. While holding locking lever open, lower the coupler over the hitch ball until ball is fully seated into the ball pocket.
4. If locking lever is pinned open, remove pin. Move locking lever to the closed position. Check that the latch is engaged by lifting up on back of locking lever. Also, check that the hitch ball is fully seated and ball clamp is below the ball. If the ball is not seated with lever in the closed position and latch engaged, DO NOT TOW.

Repeat the above steps.

5. **OPTIONAL:** Place a 5/16" pin or lock in hole shown
To Uncouple:

1. Block trailer wheels.
2. Open locking lever. While holding locking lever fully open, raise trailer off of hitch ball.

NOTE: A 5/16" diameter pin can be used to hold the locking lever open.

Hitch Coupler Troubleshooting

If the coupler becomes damaged it must be repaired or replaced before towing. When the coupler is placed on the ball, the latch should close firmly. Keep the latch mechanism lightly oiled and clean. Items to check for are as follows:

1. Latch does not grasp ball securely:
 - Check the ball size. Make sure the ball and coupler are the same size.
2. Latch does not snap into full latch position:
 - Check adjustment. Latch mechanism may be too tight.
 - Check to see that the coupler housing has not been damaged, keeping the ball hitch from fitting completely into the housing as designed.
3. Keep the tongue blocked up when not in use so the coupler and mechanism are not in the ground being exposed to dirt and moisture.
4. Apply a small amount of an automotive grease to the ball before hitching coupler to prevent wear of the two parts during towing.
5. Make sure the latch safety pin is in position before towing.

Coupler & Ball Engagement

If the coupler and towing ball resist attempts to make engagement, do not force latch assembly. Instead, check the ball diameter to verify that it conforms to Society of Automotive Engineers (SAE) specifications. Standard two-inch diameter ball should be within the limits of 2.000-inches to 1.970-inches. Balls larger than 2.000-inches will not readily fit the coupler. A two-piece coupler ball is not recommended.

If the coupler becomes damaged it must be repaired or replaced before towing. When the coupler is placed on the ball, the latch should close firmly. Keep the latch mechanism lightly oiled and clean.

Improper engagement of the coupler and ball can cause damage if the vehicles separate in transit, thus, caution must be exercised to insure a secure hook-up. Lower the coupler onto the ball with the coupler latch in the vertical position. Continue to lower the trailer tongue until the jack clears the ground, then flip the coupler latch to its locked

(horizontal) position. At this point visually observe that the ball is fully engaged in the ball hitch. An even better check to make sure the two are fully engaged is to raise the tongue of the trailer again using the jack. Raise until the ball hitch connection starts to raise the rear of the tow vehicle. If the connection was not properly made, the ball and socket will separate as the tongue of the trailer is raised.

Safety Chains

Listed in the chart below are the different class sizes of safety chains and the rated load each chain must be capable of withstanding. Your trailer is equipped with safety chains that meet the requirements of D.O.T Regulation 393.70.

TRAILER CLASS	TRAILER WEIGHT GVWR IN LBS.	MINIMUM BRAKING STRENGTH IN LBS.
I	to 2,000	2,000
II	2,000 to 3,500	3,500
III	3,500 to 5,000	5,000
IV	5,000 to 7,000	7,600

WARNING: Failure to properly attach safety chains between the trailer and tow vehicle can result in a runaway trailer.

AVERTISSEMENT: Le non-respect de fixer correctement les chaînes de sécurité entre la remorque et le véhicule remorqueur peut mener à l'emballement de la remorque.

WARNING: To avoid accidents, before trailering:

AVERTISSEMENT: Pour éviter les accidents avant de procéder à un remorquage

- Hitch only to ball size marked on coupling.
- Ball clamp must capture ball and lever or hand wheel is fully clamped.
- Cross safety chains under coupling.
- Allow only enough slack for turns.

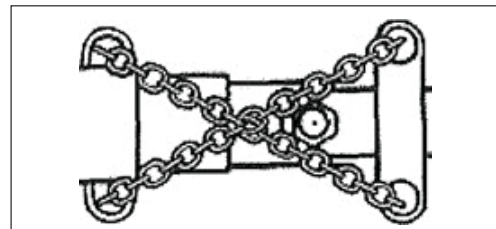

Bottom View

Important Trailer Safety Information

The safety chains on your trailer are an added insurance that it will not become detached from the tow vehicle. All safety chains are provided with an added clasp to keep them from becoming accidentally detached from the tow vehicle. Your trailer hitch on the tow vehicle should have two attaching holes or rings for attaching the safety chains, preferably one on each side of the ball hitch. Crisscross the chains under the tongue, the chain on the left side of the trailer tongue attached to the right side of the ball hitch, the chain on the right side of the trailer tongue attached to the left side of the ball hitch.

This prevents the trailer tongue from dropping to the road should the coupler or ball hitch fail. The chains should be rigged as tight as possible with just enough slack to allow tight turns to be made. This can be accomplished by twisting the chain hook in a clockwise or counterclockwise direction thus twisting the link spacing and making the chain shorter. Also by keeping your chains as short as possible you prevent them from dragging on the road and wearing the chain links. If for any reason you find it necessary to replace a safety chain, use only original equipment.

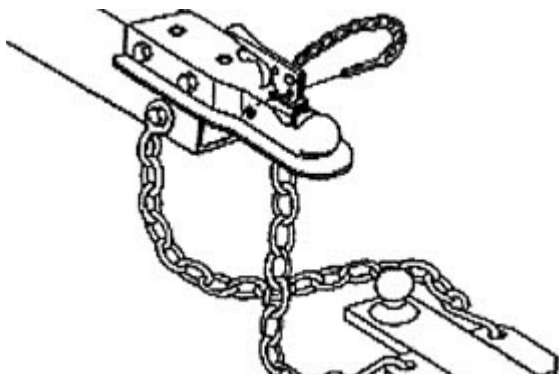

Load-Carrying Capacity

Located on the front left-hand side of the frame, (either the inside or the outside) is the VIN (Vehicle Identification Number) tag. It will show the GVWR (Gross Vehicle Weight Rating) which is the maximum load that can be applied to the tires on the trailer. The GVWR and the carrying capacity of the trailer are based on the tire size installed on the trailer.

The GVWR is the maximum carrying capacity of the trailer with its respective tires. It may not necessarily equal the total GVWR of the trailer less the empty weight of the trailer because there may be another controlling factor such as frame strength that reduces the carrying capacity to what is listed on the VIN tag.

The tire label will list the tire size that was installed on the trailer as original equipment when it was sold to you, the consumer. It also lists the maximum carrying capacity of the trailer.

What To Check And How To Check

IMPORTANT: *The total weight of the load must never exceed the weight of cargo listed on the tire label and/or the maximum load carrying capacity listed on the VIN tag on your trailer. The GVWR (Gross Vehicle Weight Rating) listed is the maximum total weight of the trailer with accessories and all cargo allowable to be carried on the tires that are installed on the trailer.*

WARNING: *Fishtailing caused from improper tongue weight on the tow vehicle hitch ball can cause loss of control of the tow vehicle and resulting serious injury or property damage.*

AVERTISSEMENT: *Une embardée causée par un poids de l'attelage inapproprié sur la boule d'attache du véhicule remorqueur peut causer une perte de contrôle du véhicule remorqueur et causer des blessures graves et des dommages à la propriété*

CAUTION: *The maximum load applied to the trailer must never exceed the carrying capacity of the trailer as stated on the VIN label and/or the tire placard. Doing so may cause failure of one or more component parts of the trailer causing potential damage to the trailer and/ or a potential accident. All concentrated loads must be spread over as large an area as possible to eliminate potential damage to the decking.*

ATTENTION: *La charge maximale appliquée à la remorque ne doit jamais excéder la capacité de charge de la remorque comme mentionné sur l'étiquette NIV et/ou le flanc du pneu. Agir de la sorte risquerait de causer une défaillance d'une ou plusieurs composantes de la remorque, causant des dommages potentiels à la remorque et/ou un accident potentiel. Toutes les charges concentrées doivent être réparties sur une surface aussi large que possible pour éliminer tout dommage potentiel au patio.*

Shown on next page is an example of the tire label that is placed on your trailer showing the items just discussed above. Once you have familiarized yourself with the information supplied on the example tire label and VIN tag, check the tire size and capacity of your trailer as shown on the VIN tag on your trailer.

TIRE AND LOADING INFORMATION RENSEIGNEMENTS SUR LES PNEUS ET LE CHARGEMENT			
The weight of cargo should never exceed XXXX kg or XXXX lbs			
TIRE	SIZE	COLD TIRE PRESS.	
REAR	XXXXXXXX	XXX KPA (XX PSI)	
INTER	XXXXXXXXXX		
FRONT	XXXXXX		
SPARE	XXXXXX		
			SEE OWNERS MANUAL FOR ADDITIONAL INFORMATION VOIR LE MANUEL DE L'USAGER POUR PLUS DE RENSEIGNEMENTS
MANUFACTURED BY: KARCHER NORTH AMERICA INC.		DATE OF MFG.: XX/XXXX	
GVWR (XXXX KG (XXXX LB))			
GAWR (EACH AXLE)	WITH TIRES	RIMS AT	COLD
XXXX KG (XXXX LB)	XXXX	XXXX	XXX KPA (XX PSI) SINGLE
THIS VEHICLE CONFORMS TO ALL APPLICABLE U.S. FEDERAL MOTOR VEHICLE SAFETY STANDARDS IN EFFECT ON THE DATE OF MANUFACTURE SHOWN ABOVE.			
V.I.N.: XXXXXXXXXXXXXXXXXXXX		TYPE: TRAILER	TRX-XXXX

Proper Weight Distribution & Tongue Weight

Ensuring that your trailer has the proper GVWR is very important. Once that has been established and you have the load on the trailer it is equally important that you have proper weight distribution.

Tongue Weight

The tongue weight on your trailer is 10%-15% of the total weight of the trailer and all the cargo that it is carrying. This is the amount of weight that is then transferred to the tow vehicle through the ball hitch.

Example: The total weight of the trailer with load is 2500 pounds. The tongue weight should not be less than 250 pounds (10%).

Too light of tongue weight can cause the trailer to “fish-tail” (sway Weight Rating) as you travel down the highway. This creates excessive strains on the tow vehicle, hitch and on the trailer itself. It can very easily lead to an accident.

To adjust for too light of a tongue weight the load must be shifted for-ward with respect to the axle. This will increase the weight that is transferred to the tongue. Adjustments should be made until the tongue weight falls within 10% -15% recommended range. Likewise, if you have too much tongue weight adjust the weight backwards with respect to the axle until the tongue weight falls in the recommended range

Tow vehicles vary on how much tongue weight they can support for proper towing.

Tire Pressure

Proper air pressure for your tires is printed on the sidewall. Check pressure while tires are cold. Do not raise or lower pressure to meet load. Pressure other than recommended pressure will lead to excessive tire wear or tire failure. Balancing recommended.

Wheels

Check wheels for hole elongation or “out of round”. This condition can be caused by lug nuts not being tight or being too tight. Trailer wheels can be damaged by chuck holes or curb jumping. You may not be aware of the road shock to the wheels without periodic checks. Replace any wheel that is bent. Replace any wheel if you see elongation of the bolt holes.

Wheel Lugs

Wheel lug nuts must be tightened with a torque wrench. Refer to the chart below for proper torque.

1. Start all bolts or nuts by hand to prevent cross threading.

2. Tighten bolts or nuts following sequence at right.

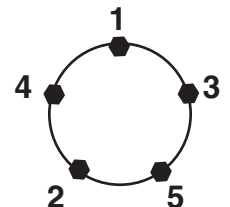

3. The tightening of the fasteners should be done in stages.

Following the recommended sequence, tighten fasteners per wheel torque chart below.

4. Wheel nuts/bolts should be torqued before first road use and after each wheel removal. Check and re-torque after the first 10 miles, 25 miles and again at 50 miles. Check periodically thereafter.

Wheel Torque Requirements

WHEEL SIZE	TORQUE SEQUENCE		
	1st Stage	2nd Stage	3rd Stage
15"	20 - 25	50 - 60	80-90

What To Check And How To Check

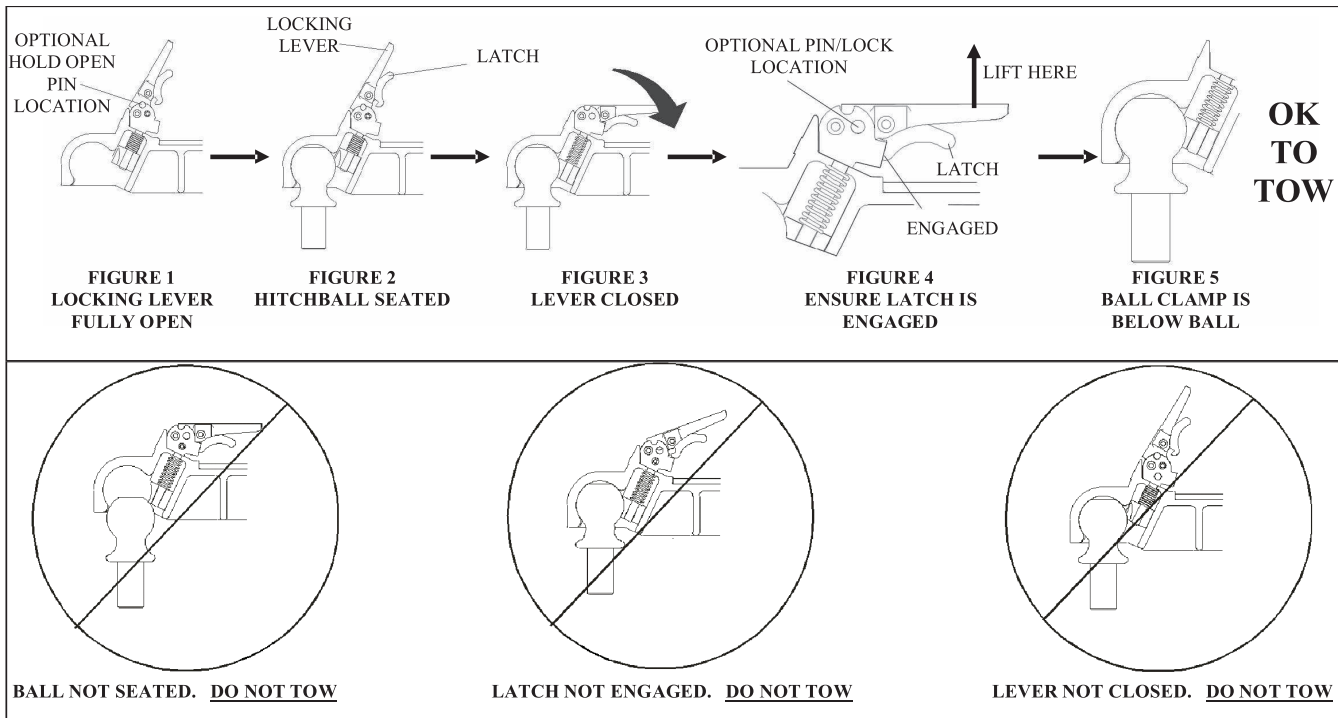

Ball Coupler Hitches

Coupler assembly includes a latch lever and latch lever safety pin or hitch pin. Be sure the latch lever is locked and the pin properly secured before moving your trailer. The pin can be engaged fully only if ball is properly seated in the coupler.

Tires







Before mounting tires onto wheels make certain that the rim size and contour is approved for the tire as shown in the Tire and Rim Association Yearbook or the tire manufacturer's catalog. Also make sure the tire will carry the rated load. If the load is not equal on all tires due to trailer weight distribution, use the tire rated for the heaviest wheel position.

NOTE: The capacity rating molded into the sidewall of the tire is not always the proper rating for the tire if used in a trailer application. Use the following guideline:

1. LT and ST tires: use the capacity rating molded into the tire.
2. Passenger Car Tires: Use the capacity rating molded into the tire sidewall divided by 1.10.

Use tire mounting procedures as outlined by the Rubber Manufacturer's Association or the tire manufacturers.

NOTE: Tire wear should be checked frequently because once a wear pattern becomes firmly established in a tire it is difficult to stop, even if the underlying cause is corrected.

WEAR PATTERN		CAUSE	ACTION
	Center Wear	Over Inflation	Adjust pressure to particular load per tire catalog.
	Edge Wear	Under Inflation	Adjust pressure to particular load per tire catalog.
	Side Wear	Loss of camber or overloading	Make sure load doesn't exceed axle rating. Align at alignment shop.
	Toe Wear	Incorrect toe-in	Align at alignment shop.
	Cupping	Out of balance	Check bearing adjustment and balance tires.
	Flat Spots	Wheel lockup & tire skidding	Avoid sudden stops when possible and adjust brakes.

Breakaway Switch & D.O.T. Wet Cell Battery

After hitching to the tow vehicle, pull the safety pin on the breakaway switch. Check to see if system is operational. Push safety pin back in to its original position.

Check battery fluid level every 60-90 days. Remove cover. There are two fill caps. Refill with distilled water only.

Breakaway Switch Mounted on an A-Frame

Attach breakaway switch cable securely in a straight line to the tow vehicle. Locate attachments so little "slack" is left in the cable, but enough slack to allow for turning without disengaging the pin. The cable will activate brakes the instant a trailer becomes disengaged. Brake adjustment is critical to stopping a disengaged trailer.

Check Breakaway System & Brakes Before Each Trip

1. Disconnect 12V plug from tow vehicle.
2. Pull breakaway pin.
3. While pin is pulled, move tow vehicle forward. Brake should be on and wheels locked.
4. Replace pin and secure to tow vehicle. Do not loop over hitch ball.
5. Plug 12V connector into tow vehicle receptacle.
6. Test brakes with brake controller.

NOTE: When disconnecting trailer from tow vehicle, make sure to replace safety pin.

Brakes

Your trailer is equipped with electric brakes.

Complete service and repair information for the electric brakes is found in the Axle Break Service Manual that is furnished with your trailer,

NOTE: It is important to strictly adhere to the axle break instructions for brake service and repair. In this way, you are protecting the validity of all applicable warranties.

Burnishing the Brakes

Brakes on a new trailer may tend to "grab" or pulsate. This is normal. To correct the situation, pull the trailer with the trailer brake control slightly engaged a short distance (about 1000 ft or until trailer does not grab or pull to one side anymore). This action smooths down the brake bands.

NOTE: Do not lock up the wheels.

Reporting Safety Defects

If you believe that your trailer has a defect which could cause a crash or could cause injury or death, you should immediately inform the National Highway Traffic Safety Administration (NHTSA) in addition to notifying Landa.

If NHTSA receives similar complaints, it may open an investigation, and if it finds that a safety defect exists in a group of trailers, it may order a recall and remedy campaign. However, NHTSA cannot become involved in individual problems between you, your dealer or Landa.

To contact NHTSA, you may either call the Auto Safety Hotline toll-free at 1-888-327-4236 (TTY: 1-800-424-9153) or write to:

NHTSA
1200 New Jersey Avenue, SE
Washington, DC 20590

You can also obtain other information about motor vehicle safety from the <http://www.safercar.gov>

Breakaway Battery on A-Frame

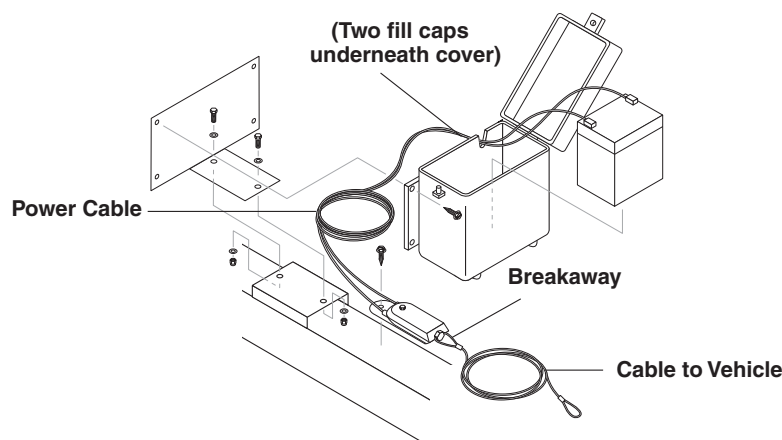

Maintenance

Preventative Maintenance

This trailer was produced with the best available materials and quality craftsmanship. However, you as the owner, have certain responsibilities for the correct care of the equipment. Attention to regular preventative maintenance procedures will assist in preserving the performance of your equipment.

MAINTENANCE SCHEDULE		
Tire Air Pressure	Inflate to proper pressure indicated on sidewall	Every Trip
Wheel Lugs, Bolts & Nuts	Tighten to proper torque specifications	Every 3000 mi or 3 mos.*
Wheel	Check for damage and or out-of-round	Every 6000 mi or 6 mos.
Coupler Ball	Check for sufficient lube. Check lock mechanism. Check for unusual wear.	Every trip
Safety Chains at Hitch Ball	Check for abrasion, distortion and general integrity of links.	Every trip
Coupler	Check for proper fastening & hitch pin in position and secure.	Every trip
Brakes	Check for proper adjustment & operation	Every trip
Breakaway Switch	Test switch operation and connections	Every trip
Breakaway Battery	Pull switch pin, check charge indicator light	Every trip
Load Distribution	Check load distribution & security	Every trip
Leveling Jacks	Check fastenings. Lube.	Every trip
Welds	Check all weld beads for cracks or separations	Every 6000 mi. or 6 mos.
Hinges	Grease zerks with a Lithium complex grease	Every 3000 mi. or 3 mos.
Tie Down Devices	Check for fracturing, distortion and improper anchoring.	Every 3000 mi., or 3 mos.
Electrical: Lights & Signals	Check to make sure all are working properly. Replace burned out bulbs.	Every trip

* Check lug nuts for tightness before initial trip, at 10 miles, 25 miles and 50 miles. Recheck at least every 3 months or 3000 miles

Axles, Hubs and Brakes

Your Landa trailer is equipped with Dexter Component Axles. The Dexter Owner's Manual is included in the materials received with your trailer. Maintenance for axles, hubs and brakes is extremely important for protecting the longevity of your trailer. It is extremely important for your personal safety and the protection of others. Follow the Dexter service recommendations exactly as described.

Please, never shortcut axle, hub and brake service and maintenance.

Parts

LANDA TRAILER

TR-6000
1.103-804.0

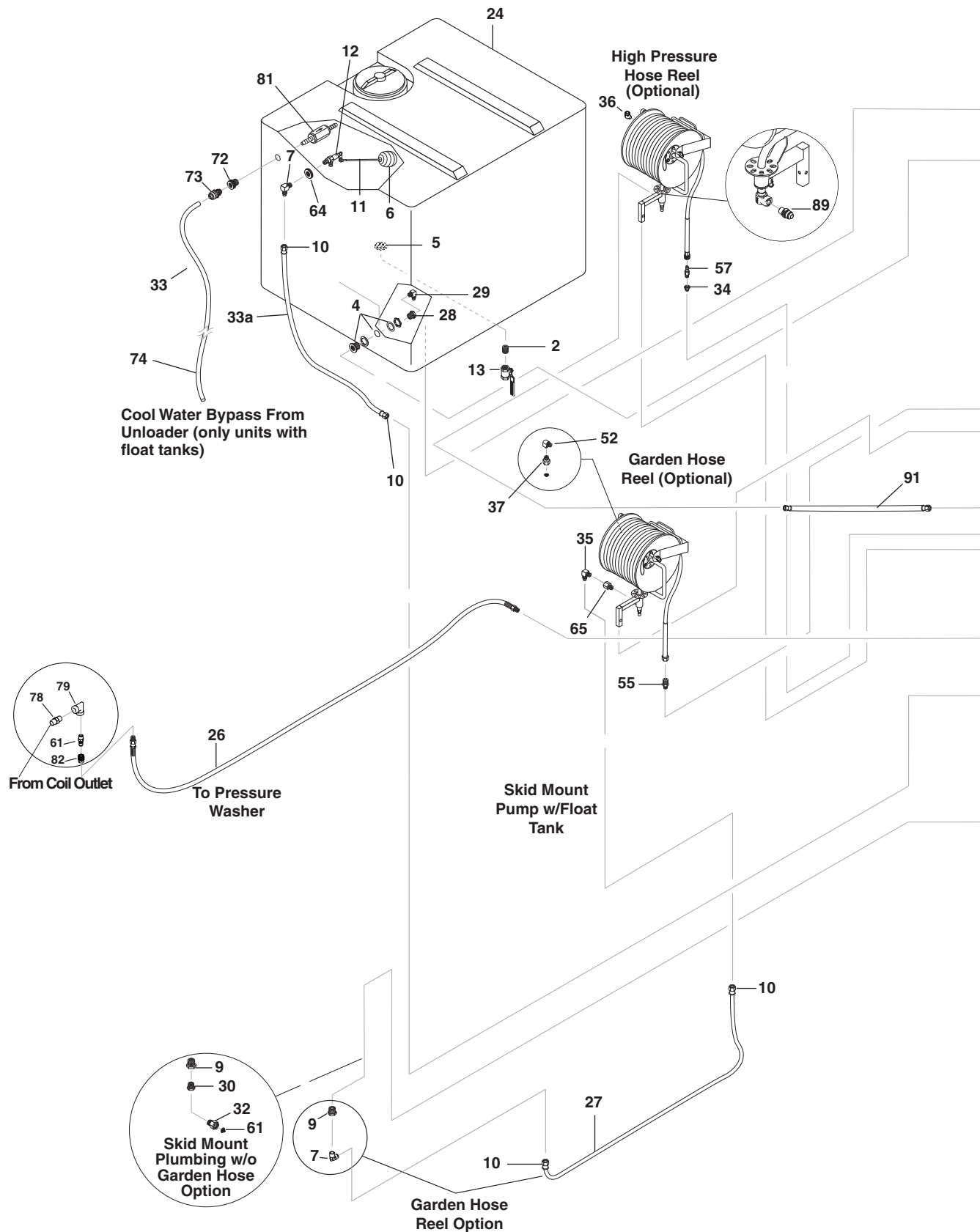

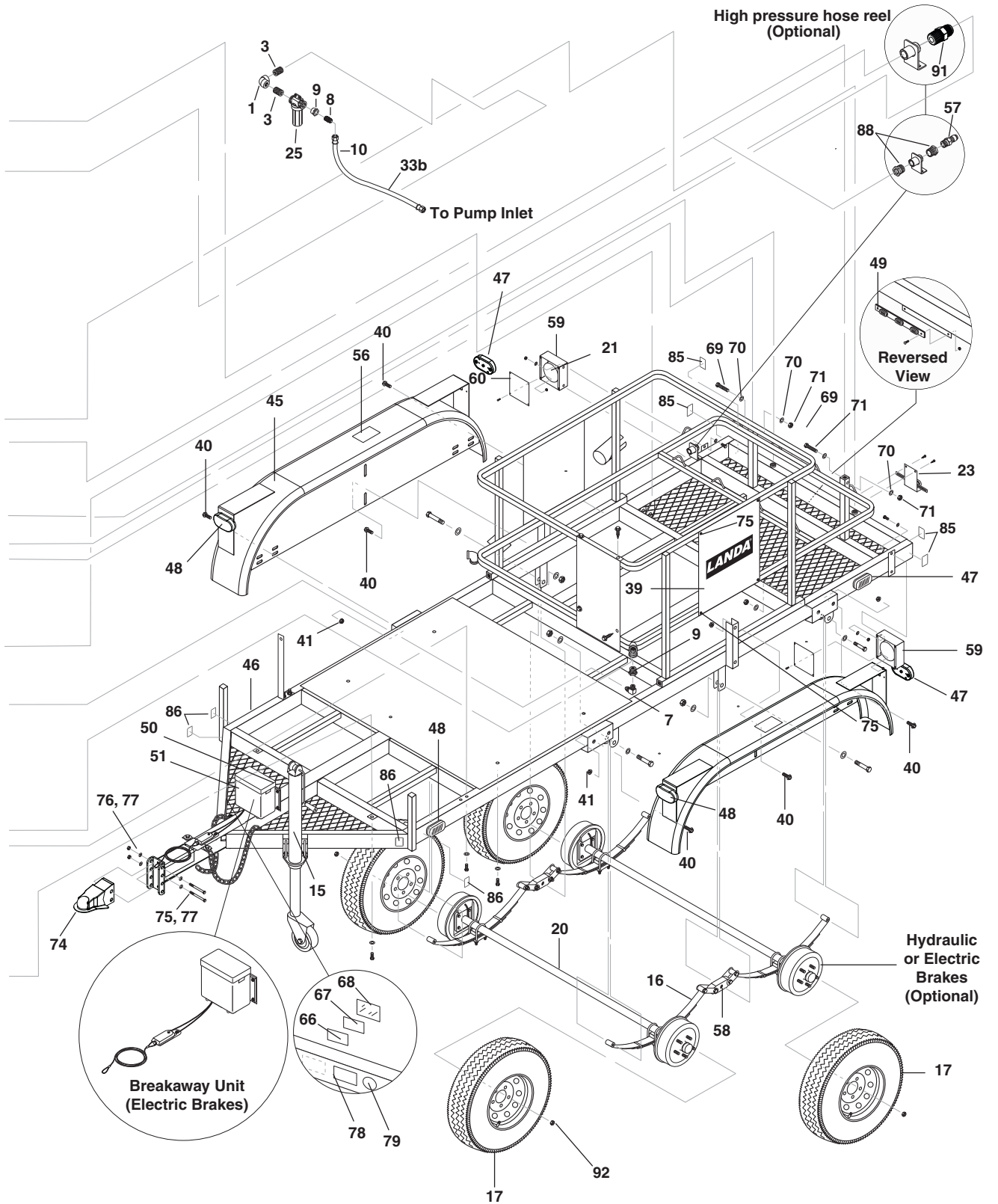

TR-6000

REF	PART NO.	QTY	DESCRIPTION	NOTES
1	8.706-376.0	1	ELBOW, 1" FIPT X FIPT, PVC 80	
2	8.706-424.0	1	NIPPLE, 1.5 X CLOSE, PVC 80	
3	8.706-439.0	2	NIPPLE, 1", PVC 80, CLOSE	
4	8.706-484.0	1	BULKHEAD, 1", POLYPRO	
5	8.758-129.0	1	BULKHEAD 1-1/2" POLYPRO BANJO	
6	8.706-512.0	1	BALL, FLOAT, BLACK PLASTIC	
7	8.757-503.0	3	ELBOW BRASS 3/4 SAE (M) X 3/4 NPTF (M)	
8	8.757-808.0	3	NIPPLE, 3/4" JIC X 3/4" PIPE	
9	8.757-672.0	3	BUSHING, 1" X 3/4" BARSTOCK	
10	9.802-152.0	3	SWIVEL, 3/4" SAE FEM PUSH-ON	
11	8.707-025.0	1	STEM, 10" FLOAT	
12	8.749-329.0	1	VALVE, 3/4" PLASTIC FLOAT	
13	8.707-342.0	1	VALVE, 1.5" BALL, FPT X FPT POLYPROPYLENE	
15	8.707-485.0	1	JACK, SWIVEL W/CASTER, 1500 LB.	
16	8.753-334.0	2	LEAF SPRINGS, 3500 LB., SW4B (PAIR)	
17	8.725-529.0	4	WHEEL/TIRE ASSY, 15" WHEEL ST205/75D15 TIRE	
18	8.707-497.0	6 ft.	CHAIN, 5/16 ZINC PLATED	
-	9.802-724.0	2	BOLT, 3/8" X 1-1/2" NC, HH, SS	NOT SHOWN
-	8.718-988.0	2	WASHER, 7/16", FLAT, SAE	NOT SHOWN
-	9.802-811.0	4	WASHER, 3/8" X 1-1/2" FENDER	NOT SHOWN
-	8.719-024.0	2	WASHER, 3/8", SS LOCK	NOT SHOWN
-	8.719-089.0	2	NUT, 3/8", HEX, NC, SS	NOT SHOWN
19	8.707-498.0	2	HOOK, "S", 5/16" ZINC PLATED	NOT SHOWN
20	8.759-373.0	2	AXLE 3500LB 73" ELECTRIC BRAKES	
-	8.759-374.0	2	AXLE 3500LB 73" HYDRAULIC BRAKES	
21	8.707-512.0	2	LAMP, STOP/TAIL/TURN, RED FLUSH MNT	
22	8.707-510.0	1	CONNECTOR, SOCKET, 7-PRONG	NOT SHOWN
-	8.707-511.0	1	PLUG, 7 PRONG	
23	8.707-513.0	1	LAMP, LICENSE W/HOLDER	
24	8.707-525.0	1	TANK, 330 GAL. HDPE CONSTR.	
25	8.707-526.0	1	STRAINER, 1" T-LINE, TRAILERS	
26	8.918-206.0	1	HOSE, 3/8" X 125", 2 WIRE, SWIVEL X SWI	PGDC ONLY
-	8.918-207.0	1	HOSE, 3/8" X 150", 2 WIRE, SWIVEL X SWI	PDHW ONLY
27	9.802-261.0	7.08 ft.	HOSE, 3/4" PUSH-ON	LOW PRESSURE HOSE OPTION
28	8.706-928.0	1	BUSHING, 1" X 1/2" BLACK POLY	
29	9.802-131.0	1	ELBOW, 1/2" JIC X 1/2", 90°	
30	8.757-486.0	1	BUSHING, 3/4" X 1/2", BRASS	
31	8.706-829.0	1	ELBOW, 1/2" STREET, BRASS	
32	8.757-203.0	1	SWIVEL, 1/2" M-NPTF x 3/4" GHF	
33a	9.802-261.0	4 ft.	HOSE, 3/4" PUSH-ON, /FT	
33b	9.802-261.0	1.67 ft.	HOSE, 3/4" PUSH-ON, /FT	
34	8.706-917.0	1	BUSHING, 1/2" X 3/8" BRASS	HIGH PRESSURE OPTION
35	8.757-202.0	1	ELBOW BRASS 3/4 SAE (M) X 1/2 NPTF (M)	
36	8.757-551.0	1	ELBOW STREET STEEL 3/8" 45°	
37	8.757-800.0	1	SWIVEL BRASS 3/8 NPTF (M) X 3/4 GHF	
38	9.802-206.0	1	CLAMP, HOSE	
39	8.912-401.0	2	PLATE, SIGNAGE, TRAILERS	OPTION
40	9.802-767.0	12	SCREW, 3/8" X 3/4" HH NC WHIZ LOC	
41	9.802-781.0	12	NUT, 3/8", FLANGE WHIZ LOC, NC	
42	8.706-846.0	1	TEE, 3/4" FEMALE PIPE	
43	9.802-794.0	8	NUT, CAGE, 1/4" X 12 GA	
44	8.706-881.0	1	NIPPLE, 3/4" PIPE X 1/2" PIPE	
45	8.924-311.0	2	ASSY, TANDEM FENDER TR-6000 W/ LIGHT BRACKETS	
46	8.924-295.0	1	WLMT, FRAME, TR-3500, ADJST HEIGHT	
-	8.924-347.0	1	WLMT, FRAME, TR-3500 HYDRAULIC	

REF	PART NO.	QTY	DESCRIPTION	NOTES
47	8.707-507.0	4	LAMP, SIDE MARKER, RED	
48	8.707-508.0	4	LAMP, SIDE MARKER, AMBER	
49	8.707-509.0	1	LAMP, IDENTIFICATION BAR	
50	8.912-403.0	1	BRACKET, BREAKAWAY TRAILER	
51	8.707-506.0	1	BREAKAWAY KIT W/BATTERY	
52	8.757-482.0	1	ELBOW, STREET, 3/8", 45°, BRASS	
53	8.707-233.0	1	VALVE, 1" BALL, BRASS	
54	9.802-064.0	3	GROMMET, RUBBER NOZZLE HOLDER	NOT SHOWN
55	8.706-968.0	1	FITTING, 3/4" GARDEN HS X 1/2"	
56	8.900-522.0	2	LABEL, WARNING DO NOT STAND OR STEP	
57	9.802-171.0	2	COUPLER, 3/8" PLUG, MALE, STEEL/ZINC	(1 OPTIONAL)
58	8.759-362.0	8	BOLT U 2.375"X5.5"X0.5" 4202-1	NOT SHOWN
59	8.912-398.0	2	BRACKET TAIL LIGHT	
60	8.912-399.0	2	COVER, LIGHT BRACKET	
61	9.804-016.0	1	FILTER SCREEN WASHER, GARDEN HOSE/30MESH	
62	9.802-132.0	1	ELBOW, 3/4" JIC X 1/2", 90°	
63	8.706-117.0	2	NIPPLE, 1" CLOSE, BLACK	
64	9.802-052.0	1	BULKHEAD, 3/4" POLYPRO	
65	8.706-992.0	1	ADAPTER, 1/2" X 3/8"	
66	8.749-879.0	2.5 x 7"	ADHESIVE, 10" ROLL	
67	-	1	VIN PLATE	
68	9.807-349.0	1	LABEL, CLEAR LEXAN	
69	9.802-730.0	2	BOLT, 3/8" X 2-1/2" GR5 ZINC	
70	9.802-807.0	4	WASHER, 3/8", SAE, FLAT ZINC	
71	9.802-779.0	2	NUT, 3/8", ESNA, NC	
72	8.750-743.0	1	BULKHEAD, 1/2" POLY	
73	9.802-514.0	1	STRAIN RELIEF, LT, Str, 1/2 NPT,,23-.45D	
74	-	-	COOL BYPASS HOSE FROM PUMP	
75	9.802-799.0	8	SCREW, #14 X 1", TEK BLK, ZINC	OPTION
74	8.755-306.0	1	COUPLER, 2-5/16TH IN BALL, ADJST HGT	
75	8.755-310.0	2	5/8-11 X 4.5 IN. GRADE 5 BOLT, ECOGUARD COATED	
76	8.755-309.0	2	5/8 INCH GRADE 9 LOCKNUT, ECOGUARD COATED	
77	8.755-311.0	4	5/8 INCH SAE FLAT WASHER, ECOGUARD COATED	
78	-	1	TIRE PLACARD LABEL	
-	9.803-483.0	1	LABEL, CLEAR LEXAN, 2.75" X 5.0"	
79	8.755-291.0	1	LABEL, NATM	
80	9.800-034.0	1	LABEL CLEAR LEXAN 4.30" X 4.70"	NOT SHOWN
81	8.709-369.0	1	CHECK VALVE PVC 1/4 BARB x BAR	ONLY ON UNITS WITH FLOAT TANKS
82	9.802-166.0	1	COUPLER 3/8" SOCKET, FEMALE, BRASS	
83	8.705-974.0	1	NIPPLE, 3/8" HEX STEEL-P/N-C3069X6	
84	8.706-167.0	1	ELBOW, 3/8" FPT, 90 DGR, P/N-TF3509X6	
85	8.757-910.0	4	RED REFLECTIVE LABEL B489R	
86	8.757-911.0	4	AMBER REFLECTIVE LABEL B489A	
87	8.932-968.0	1	LABEL, INTENDED FOR OUTDOOR USE - USA	
88	8.757-513.0	2	BUSHING, 1/2" NPTF(M) X 3/8" NPTF(F),STEEL	
89	8.757-655.0	1	ADAPTER STEEL 1/2 JIC (M) X 3/8 NPTF (M)	
90	8.757-508.0	1	ADAPTER STEEL 1/2 SAE (M) X 1/2 NPTF (M)	
91	8.918-425.0	1	HOSE, 3/8" X 29",2 WIRE, PRESSURE LO	
92	8.759-371.0	20	NUT LUG 0.5625"-18 60 DEG CONE	
93	8.759-363.0	4	PLATE UBOLT 2.375 RD 1.75" SPRING 4202-3	NOT SHOWN
94	8.759-364.0	16	NUT HEX 0.5" 4201-2	NOT SHOWN
95	8.759-365.0	16	WASHER LOCK 0.5" 4201-4	NOT SHOWN
96	8.759-368.0	14	BOLT SHACKLE 0.5625"X3" 4101-5	NOT SHOWN
97	8.759-369.0	14	NUT HEX TOP LOCK 0.5625" 4101-6	NOT SHOWN
98	8.759-372.0	2	BAR EQUALIZER EQ-104 NOT SHOWN	NOT SHOWN
99	8.759-379.0	8	STRAP SHACKLE 3.125" 4101-2C	NOT SHOWN

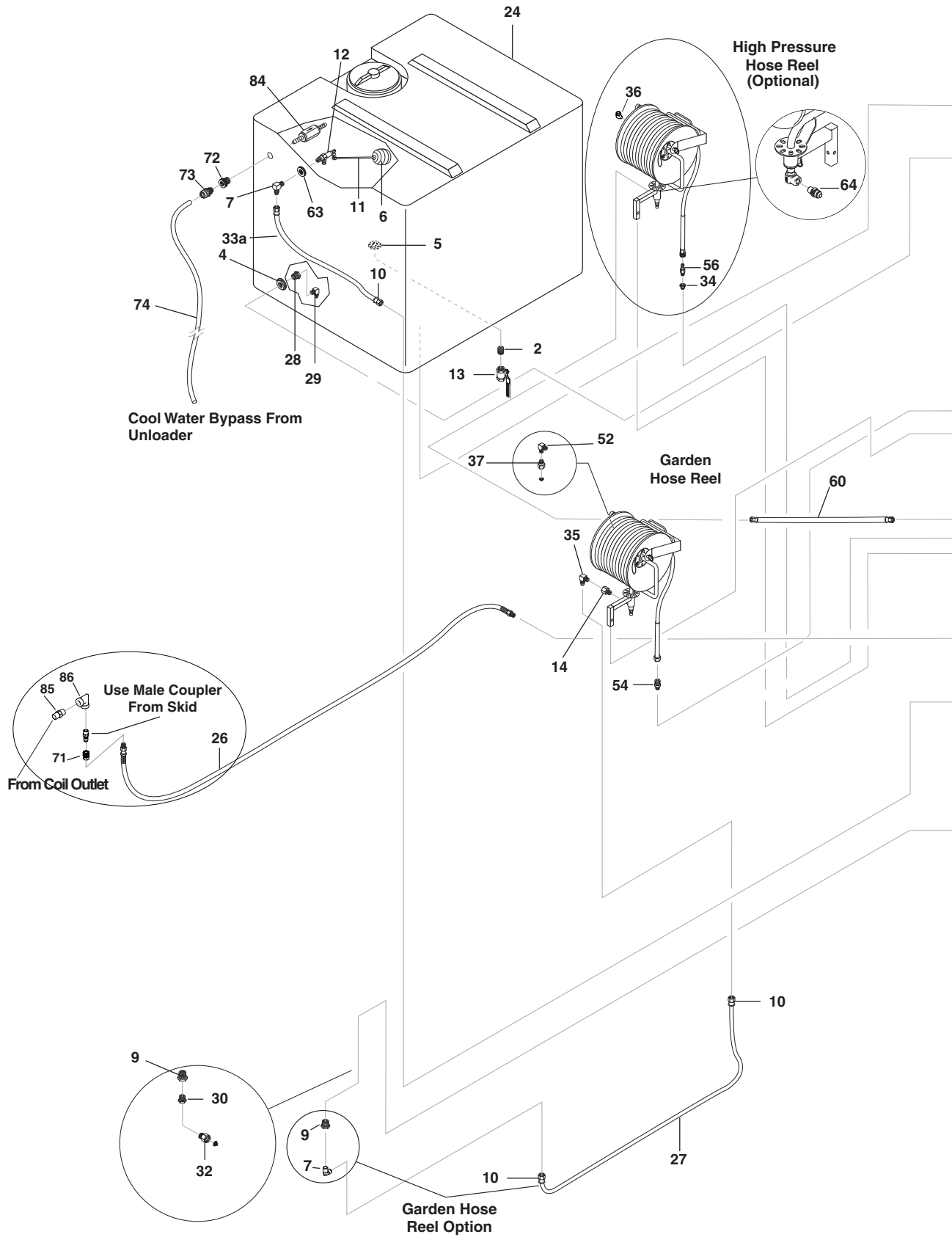

TR-6000 PGHW

REF	PART NO.	QTY	DESCRIPTION	NOTES
1	8.706-376.0	1	ELBOW, 1" FIPT X FIPT, PVC 80	
2	8.706-424.0	1	NIPPLE, 1.5 X CLOSE, PVC 80	
3	8.706-439.0	2	NIPPLE, 1", PVC 80, CLOSE	
4	8.706-484.0	1	BULKHEAD, 1" POLYPRO, #60427	
5	8.758-129.0	1	BULKHEAD 1-1/2" POLYPRO BANJO	
6	8.706-512.0	1	BALL, FLOAT, BLACK PLASTIC	
7	9.803-557.0	3	ELBOW, 3/4" SAE X 3/4", 90°	
8	8.706-899.0	1	NIPPLE, 3/4" JIC X 3/4" PIPE	
9	8.706-929.0	3	BUSHING, 1" X 3/4" BARSTOCK	
10	9.802-152.0	4	SWIVEL, 3/4" SAE FEM, PUSH-ON	
10	9.802-152.0	6	SWIVEL, 3/4" SAE FEM, PUSH-ON	LOW PRESSURE HOSE OPTION
11	8.707-025.0	1	STEM, 10" FLOAT	
12	8.749-329.0	1	VALVE, 3/4" PLASTIC FLOAT	
13	8.707-342.0	1	VALVE, 1.5" BALL, FPT X FPT POLYPROPYLENE	
14	8.706-992.0	1	ADAPTER, 1/2" X 3/8"	
15	8.707-485.0	1	JACK, SWIVEL W/CASTER, 1500 LB.	
16	8.753-334.0	2	LEAF SPRINGS, 3500 LB., SW4B (PAIR)	
17	8.725-529.0	4	WHEEL/TIRE ASSY, 15" WHEEL, ST205/75D15 TIRE	
18	8.707-497.0	6 ft.	CHAIN, 5/16 ZINC PLATED	
-	9.802-724.0	2	BOLT, 3/8" X 1-1/2" NC, HH, SS	NOT SHOWN
-	9.802-807.0	4	WASHER, 3/8", SAE, FLAT ZINC	NOT SHOWN
-	9.802-812.0	4	WASHER, 3/8" x 1-1/2", FENDER, SAE	NOT SHOWN
-	9.802-780.0	2	NUT, 3/8" STAINLESS, ESNA, NC	NOT SHOWN
19	8.707-498.0	2	HOOK, "S", 5/16" ZINC PLATED	NOT SHOWN
20	8.759-373.0	2	AXLE 3500LB 73" ELECTRIC BRAKES	
-	8.759-374.0	2	AXLE 3500LB 73" HYDRAULIC BRAKES	
21	8.707-512.0	2	LAMP, STOP/TAIL/TURN, RED,	
22	8.707-510.0	1	CONNECTOR, SOCKET, 7-PRONG	NOT SHOWN
-	8.707-511.0	1	PLUG, 7 PRONG	
23	8.707-513.0	1	LAMP, LICENSE W/HOLDER	
24	8.707-525.0	1	TANK, 330 GAL. HDPE CONSTR.	
25	8.707-526.0	1	STRAINER, 1" T-LINE, TRAILERS	
26	8.918-206.0	1	HOSE, 3/8" X 125", 2 WIRE, SWIVEL X SWI	
27	9.802-261.0	7 ft.	HOSE, 3/4" PUSH-ON	LOW PRESSURE OPTION
28	8.706-928.0	1	BUSHING, 1" X 1/2" BLACK POLY	
29	9.802-131.0	1	ELBOW, 1/2" JIC X 1/2", 90°	
30	8.706-925.0	1	BUSHING, 3/4" X 1/2" PIPE	
31	8.706-829.0	1	ELBOW, 1/2" STREET, BRASS	
32	9.802-146.0	1	SWIVEL, 1/2" MP X 3/4" GHF W/S	
33a	9.802-261.0	4 ft.	HOSE, 3/4" PUSH-ON, /FT	
33b	9.802-261.0	1.67 ft.	HOSE, 3/4" PUSH-ON, /FT	
34	8.706-917.0	1	BUSHING, 1/2" X 3/8" BRASS	HIGH PRESSURE OPTION
35	9.802-132.0	1	ELBOW, 3/4" JIC X 1/2" MPT	
36	9.802-041.0	1	ELBOW, 3/8" STL, STREET, 45°	
37	9.802-147.0	1	SWIVEL, 3/8" MP X 3/4" GHF W/S	
38	9.802-206.0	1	CLAMP, HOSE	NOT SHOWN
39	8.912-401.0	1	PLATE, SIGNAGE, TRAILERS	
40	9.802-767.0	12	SCREW, 3/8" X 3/4" WHIZ LOC	
41	9.802-781.0	12	NUT, 3/8", FLANGE WHIZ LOC, NC	
42	8.706-846.0	1	TEE, 3/4" FEMALE PIPE	
43	9.802-794.0	8	NUT, CAGE, 1/4" X 12 GA	NOT SHOWN
44	8.706-881.0	1	NIPPLE, 3/4" PIPE X 1/2" PIPE	
45	8.924-311.0	2	ASSY, TANDEM FENDER TR-6000 W/ LIGHT BRACKETS	
46	8.924-295.0	1	WLMT, FRAME, TR-3500, ADJST HEIGHT	
-	8.924-347.0	1	WLMT, FRAME, TR-3500, HYDRAULIC	

REF	PART NO.	QTY	DESCRIPTION	NOTES
47	8.707-507.0	4	LAMP, SIDE MARKER, RED	
48	8.707-508.0	4	LAMP, SIDE MARKER, AMBER	
49	8.707-509.0	1	LAMP, IDENTIFICATION BAR	
50	8.912-403.0	1	BRACKET, BREAKAWAY TRAILER	NOT SHOWN
51	8.707-506.0	1	BREAKAWAY KIT W/BATTERY	
52	8.706-834.0	1	ELBOW, 3/8" STREET, 45 DGR, BRASS	
53	9.802-064.0	3	GROMMET, RUBBER, NOZZLE HOLDER	NOT SHOWN
54	8.706-968.0	1	FITTING, 3/4" GARDEN HS X 1/2"	
55	8.900-522.0	2	LABEL, CLP WARNING, DO NOT STAND OR STEP	
56	9.802-171.0	2	COUPLER, 3/8" PLUG, MALE, STEEL/ZINC	(1 OPTIONAL)
57	8.759-362.0	8	BOLT U 2.375"X5.5"X0.5" 4202-1	NOT SHOWN
58	8.912-398.0	2	BRACKET TAIL LIGHT	
59	8.912-399.0	2	COVER, LIGHT BRACKET	
60	8.918-425.0	1	HOSE, 3/8" X 29", 2 WIRE, PRESSURE LO	
61	9.802-132.0	1	ELBOW, 3/4" JIC X 1/2", 90°	
62	8.757-508.0	1	ADAPTER STEEL 1/2 SAE (M) X 1/2 NPTF (M)	
63	9.802-052.0	1	BULKHEAD, 3/4" POLYPRO	
64	8.757-655.0	1	ADAPTER STEEL 1/2 JIC (M) X 3/8 NPTF (M)	
65	8.749-879.0	1	ADHESIVE, 10" ROLL, 2.5" X 7"	
66	-	1	VIN PLATE	
67	9.807-349.0	2	LABEL, CLEAR LEXAN	
68	9.802-730.0	2	BOLT, 3/8" X 2-1/2" GR5 ZINC	
69	9.802-807.0	4	WASHER, 3/8", SAE, FLAT ZINC	
70	9.802-779.0	2	NUT, 3/8", ESNA, NC	
71	9.802-166.0	1	COUPLER 3/8" SOCKET, FEMALE, BRASS	
72	8.750-743.0	1	BULKHEAD, 1/2" POLY	
73	9.802-514.0	1	STRAIN RELIEF, LT, Str, 1/2 NPT, .23-.45D	
74	-	-	COOL BYPASS HOSE FROM PUMP	
75	8.916-826.0	1	GUARD, EXHAUST, TRAILER	
76	9.802-799.0	12	SCREW, #14 X 1", TEK BLK, ZINC	
77	8.755-306.0	1	COUPLER, 2-5/16TH IN BALL, ADJST HGT	
78	8.755-310.0	2	5/8-11 X 4.5 INCH GRADE 5 BOLT, ECOGUARD COATED	
79	8.755-309.0	2	5/8 INCH GRADE 9 LOCKNUT, ECOGUARD COATED	
80	8.755-311.0	4	5/8 INCH SAE FLAT WASHER, ECOGUARD COATED	
81	-	1	TIRE PLACARD LABEL	
82	8.755-291.0	1	LABEL, NATM	
83	9.800-034.0	1	LABEL CLEAR LEXAN 4.30" X 4.70"	
84	8.709-369.0	1	CHECK VALVE PVC 1/4 BARB x BAR	
85	8.705-974.0	1	NIPPLE, 3/8" HEX STEEL-P/N-C3069X6	
86	8.706-167.0	1	ELBOW, 3/8" FPT, 90 DGR, P/N-TF3509X6	
87	8.757-910.0	4	RED REFLECTIVE LABEL B489R	
88	8.757-911.0	4	AMBER REFLECTIVE LABEL B489A	
89	8.932-968.0	1	LABEL, INTENDED FOR OUTDOOR USE - USA	
90	8.757-513.0	2	BUSHING, 1/2"NPTF(M) X 3/8"NPTF(F),STEEL	
91	8.759-371.0	20	NUT LUG 0.5625"-18 60 DEG CONE	
92	8.759-363.0	4	PLATE UBOLT 2.375 RD 1.75" SPRING 4202-3	NOT SHOWN
93	8.759-364.0	16	NUT HEX 0.5" 4201-2	NOT SHOWN
94	8.759-365.0	16	WASHER LOCK 0.5" 4201-4	NOT SHOWN
95	8.759-368.0	14	BOLT SHACKLE 0.5625"X3" 4101-5	NOT SHOWN
96	8.759-369.0	14	NUT HEX TOP LOCK 0.5625" 4101-6	NOT SHOWN
97	8.759-372.0	2	BAR EQUALIZER EQ-104	NOT SHOWN
98	8.759-379.0	8	STRAP SHACKLE 3.125" 4101-2C	NOT SHOWN

Trailer Options & Accessories

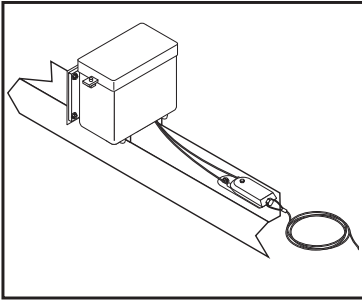

Electric Breakaway Brake Kit

Brakes

PART NO.	DESCRIPTION	FITS THESE MODELS
8.902-437.0	KIT, ELECTRIC BRAKES (ONE AXLE)	TR-6000
8.902-438.0	KIT, SURGE BRAKES (ONE AXLE)	TR-6000
8.707-506.0	KIT, BREAKAWAY, ELECTRIC BRAKES	ALL MODEL

Landa Hose Reel Kits (Hose NOT Included)

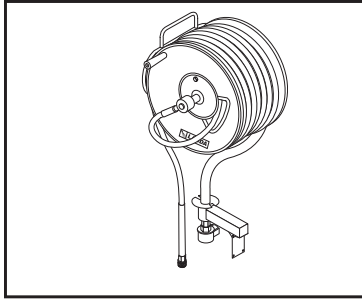

Hose Reel

PART NO.	DESCRIPTION	FITS THESE MODELS
8.902-447.0	KIT, FOR 100' OF 3/8" HIGH PRESSURE HOSE	ALL MODELS
8.902-448.0	KIT, FOR 200' OF 3/8" HIGH PRESSURE HOSE	ALL MODELS
8.902-449.0	KIT, FOR 100' OF 3/4" GARDEN HOSE	ALL MODELS

Chemical Rack

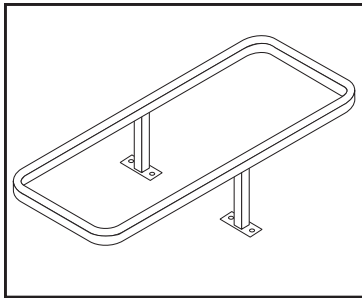

Chemical Rack

PART NO.	DESCRIPTION	FITS THESE MODELS
8.912-409.0	2-5 GAL. BUCKET CHEMICAL RACK	TR-3500, TR-6000

Mounting Kits

PART NO.	DESCRIPTION	FITS THESE MODELS
8.902-454.0	KIT, MOUNT & PLUMBING	SGHW, SDHW, PGHW, SEHW
8.902-456.0	KIT, MOUNT & PLUMBING	PGDC, MHP
25-1022	KIT, MOUNT & PLUMBING	MVP

Fuel Tank & Tool Box

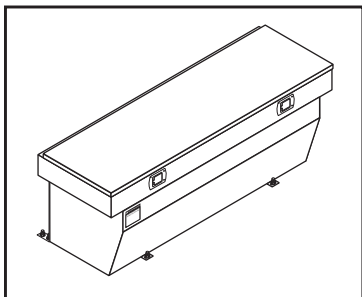

Fuel Tank & Tool Box

PART NO.	DESCRIPTION	FITS THESE MODELS
8.902-464.0	KIT, FUEL & TOOL, 45 GAL. TANK	TR-6000
8.902-465.0	KIT, FUEL & TOOL, 24 GAL TANK	TR-6000
8.707-521.0	KIT, FUEL & TOOL BOX ONLY, 45 GAL. TANK	TR-6000
8.707-522.0	KIT, FUEL & TOOL BOX, 24 GAL. TANK	TR-6000

Vinyl Skid Cover

PART NO.	DESCRIPTION	FITS THESE MODELS
2-9025	VINYL SKID COVER	SGHW, SDHW
2-9026	VINYL SKID COVER	PGHW, PGDC, SEHW
2-9029	VINYL SKID COVER	MVP

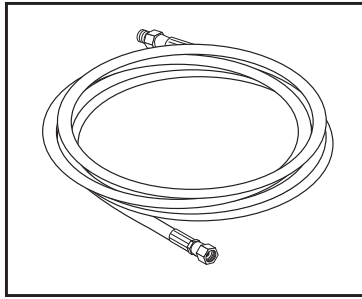

High Pressure Hose

High Pressure Hoses

PART NO.	DESCRIPTION	FITS THESE MODELS
8.739-028.0	3/8" X 100', 1-WIRE, TUFF-SKIN	
8.739-074.0	3/8" X 100', 2-WIRE, TUFF-SKIN	
8.739-220.0	3/8" X 100', 2-WIRE, TUFF-FLEX, BLUE	

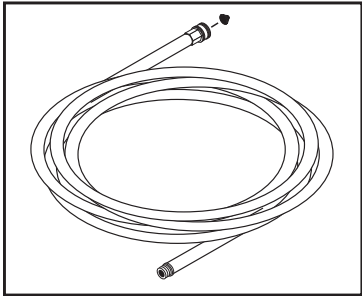

Garden Hose

Garden Hoses

PART NO.	DESCRIPTION	FITS THESE MODELS
8.711-798.0	50' X 3/4"	
8.711-799.0	75' X 3/4"	
8.711-800.0	100' X 3/4"	

Chrome/Wheel Fender

PART NO.	DESCRIPTION	FITS THESE MODELS
8.902-466.0	UPGRADE TO CHROME WHEELS (PER PAIR)	All Models
8.902-468.0	UPGRADE TO CHROME FENDER ASSY. TANDEM AXLE (PER PAIR)	TR-6000
8.707-493.0	CHROME WHEEL WITH ST205/75R14/C TIRE (EACH)	All Models

Signage

PART NO.	DESCRIPTION	FITS THESE MODELS
8.902-469.0	SIGNAGE PLATE	ALL MODELS

WIRE COLOR & GAUGE

- (#1-WHITE/14 GAUGE)
- (#2-BLUE/12 GAUGE)
- (#3-GREEN/14 GAUGE)
- (#4-BLACK/10 GAUGE)
- (#5-RED/12 GAUGE)
- (#6-BROWN/14 GAUGE)
- (#7-YELLOW/14 GAUGE)

TRAILER

- (#1-WHITE) COMMON GROUND TO FRAME
- (#2-BLUE) ELECTRIC BRAKE
- (#3-GREEN) TAIL,RUNNING,LICENSE LIGHTS
- (#4-BLACK) AUXILIARY,DOME,CHARGE LINE
- (#5-RED) LEFT STOP & TURN LIGHTS
- (#6-BROWN) RIGHT STOP & TURN LIGHTS
- (#7-YELLOW) AUXILIARY (NOT USED)

TOW VEHICLE

- (#1) COMMON GROUND
- (#2) ELECTRIC BRAKE
- (#3) TAIL,RUNNING,LICENSE LIGHTS
- (#4) AUXILIARY,DOME,CHARGE LINE
- (#5) LEFT STOP & TURN LIGHTS
- (#6) RIGHT STOP & TURN LIGHTS
- (#7) AUXILIARY (NOT USED)

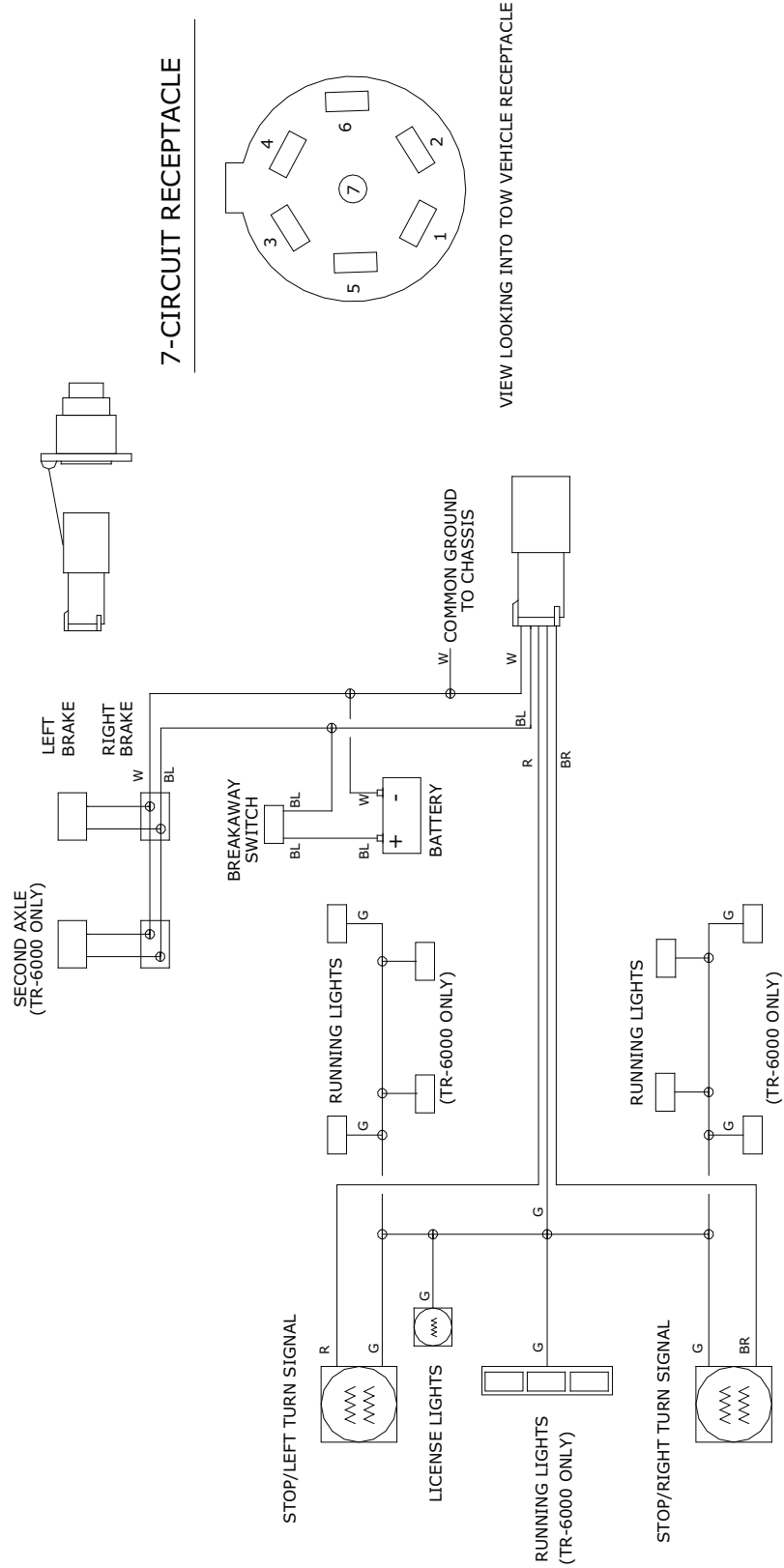

7-CIRCUIT RECEPTACLE

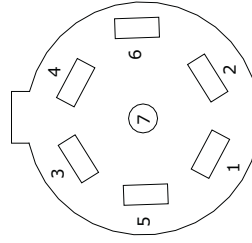

VIEW LOOKING INTO TOW VEHICLE RECEPTACLE

LANDA[®]

8.913-956.0 • Printed in U.S.A.