

KÄRCHER

makes a difference

SSG

English

02

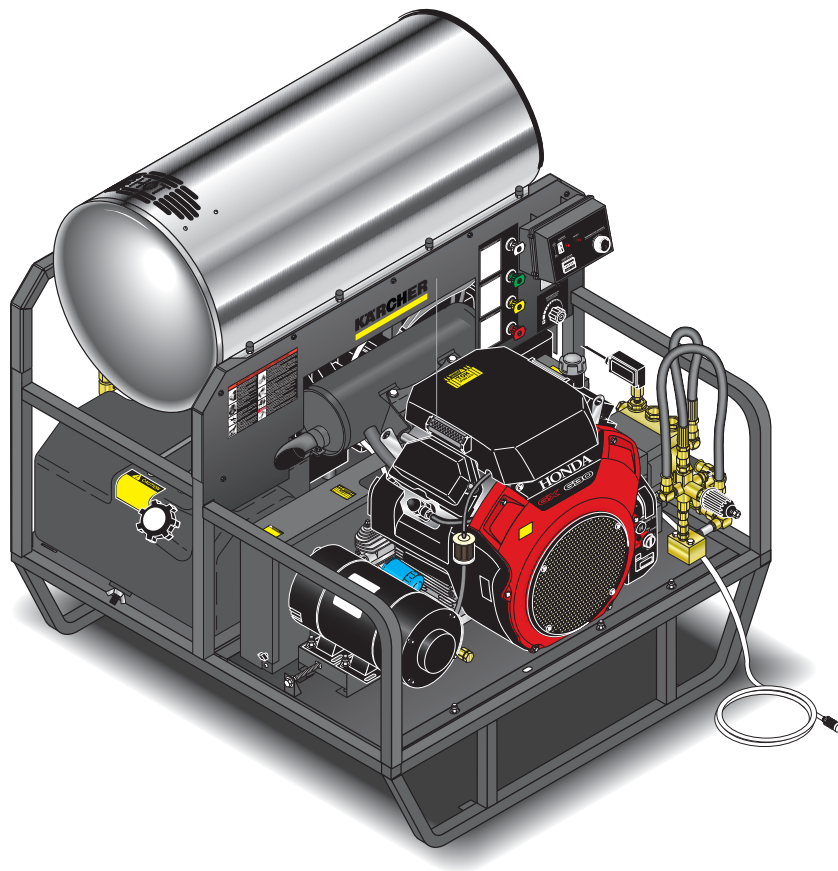

SHOP PRESSURE WASHER PARTS

shoppressurewasherparts.com | (888) 269-0172



Register
your product

www.kaercher.com/welcome



9.801-193.0-BD 01/03/22

Machine Data Label

Model:	_____
Date of Purchase:	_____
Serial Number:	_____
Dealer:	_____
Address:	_____
Phone Number:	_____
Sales Representative:	_____

MODELS:

SSG-403037E
1.110-579.0

SSG-503027E
1.110-580.0

SSG-503027E/G
1.110-581.0

SSG-503537E
1.110-582.0

SSG-503537E/G
1.110-583.0

SSG-603537E
1.110-584.0

SSG-603537E/G
1.110-585.0

SSG-503537E/G
1.110-603.0

Machine Data Label	2
Table of Contents	3
How To Use This Manual	4

Safety

Introduction & Safety Information	5
---	---

Operations

Component Identification	9
Assembly Instructions	10
Battery Installation	10
Operating Instructions	11
Detergents & General Cleaning Techniques	14
Thermal Pump Protection	14
Cleaning Tips	14
Rinsing	15
Shutting down & Cleaning Up	16
Storage	17
After Extended Storage	17
Engine Maintenance	17

Maintenance

Preventative Maintenance	18
Maintenance and Service	18
Oil Change Chart	22
Maintenance Chart	22
Troubleshooting	23

Parts

SSG	28
SSG Parts List	30
SSG Parts List	35
Float Tank	36
Control Panel	38
Hose & Spray Gun	40
Wayne Burner Specifications	41
Pump Specifications	41
Generator Specifications	41
Engine Specifications	41
Pump - 5-2300, 5-3000, 6-3200 KT.2 Series	42
Wayne EHASR DC Burner	44
Wayne Burner - AC	46
VRT 3 Unloader	48
Unloader Adjustment Procedures	49

How To Use This Manual

This manual contains the following sections:

- How to Use This Manual
- Safety
- Operations
- Maintenance
- Parts List

The HOW TO USE THIS MANUAL section will tell you how to find important information for ordering correct repair parts.

Parts may be ordered from authorized dealers. When placing an order for parts, the machine model and machine serial number are important. Refer to the MACHINE DATA box which is filled out during the installation of your machine. The MACHINE DATA box is located on the inside of the front cover of this manual.

Model: _____
Date of Purchase: _____
Serial Number: _____
Dealer: _____
Address: _____
Phone Number: _____
Sales Representative: _____

The model and serial number of your machine are located on the back of the machine.

The SAFETY section contains important information regarding hazardous or unsafe practices of the machine. Levels of hazards are identified that could result in product damage, personal injury, or severe injury resulting in death.

The OPERATIONS section is to familiarize the operator with the operation and function of the machine.

The MAINTENANCE section contains preventive maintenance to keep the machine and its components in good working condition. They are listed in this general order:

- Storage
- Maintenance
- Troubleshooting

The PARTS LIST section contains assembled parts illustrations and corresponding parts list. The parts lists include a number of columns of information:

- **REF** – column refers to the reference number on the parts illustration.
- **PART NO.** – column lists the part number for the part.
- **QTY** – column lists the quantity of the part used in that area of the machine.
- **DESCRIPTION** – column is a brief description of the part.
- **NOTES** – column for information not noted by the other columns.

NOTE: If a service or option kit is installed on your machine, be sure to keep the KIT INSTRUCTIONS which came with the kit. It contains replacement parts numbers needed for ordering future parts.

NOTE: The manual part number is located on the lower right corner of the front cover.

Introduction & Safety Information

Thank you for purchasing this Kärcher Pressure Washer. We reserve the right to make changes at any time without incurring any obligation.

Owner/User Responsibility:

The owner and/or user must have an understanding of the manufacturer's operating instructions and warnings before using this pressure washer. Warning information should be emphasized and understood. If the operator is not fluent in English, the manufacturer's instructions and warnings shall be read to and discussed with the operator in the operator's native language by the purchaser/owner, making sure that the operator comprehends its contents.

Owner and/or user must study and maintain for future reference the manufacturers' instructions.

The operator must know how to stop the machine quickly and understand the operation of all controls. Never permit anyone to operate the engine without proper instructions.

Save these Instructions:

This manual should be considered a permanent part of the machine and should remain with it if machine is resold.

When ordering parts, please specify model and serial number. Use only identical replacement parts.

This machine is to be used only by trained operators.



WARNING: To reduce the risk of injury, read operating instructions carefully before using.

AVERTISSEMENT : Pour réduire le risque de blessures, lire attentivement les instructions de fonctionnement avant l'utilisation.

1. Read the owner's manual thoroughly. Failure to follow instructions could cause malfunction of machine and result in death, serious bodily injury and/or property damage.
2. Know how to stop the machine and bleed pressure quickly. Be thoroughly familiar with the controls.
3. Stay alert — watch what you are doing.



WARNING: Keep wand, hose, and water spray away from electric wiring or fatal electric shock may result.

AVERTISSEMENT : Garder la lance, le boyau et le jet d'eau à l'écart de tout câblage électrique ou des chocs électriques mortels pourraient survenir.

4. All installations must comply with local codes. Contact your electrician, plumber, utility company or the selling distributor for specific details.

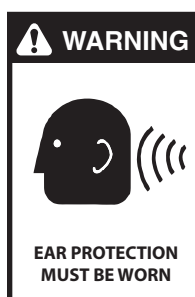

WARNING: This machine exceeds 85 db appropriate ear protection must be worn.

AVERTISSEMENT : Cette machine excède 85 dB et une protection de l'ouïe appropriée doit être portée.



WARNING: High pressure spray can cause paint chips or other particles to become airborne and fly at high speeds. To avoid personal injury, eye, hand and foot safety devices must be worn.

AVERTISSEMENT : Un jet haute pression peut écailler la peinture ou provoquer l'émission d'autres particules dans l'air et leur projection à hautes vitesses. Pour éviter les lésions corporelles, une protection des yeux, du visage, des mains et des pieds doit être portée lors de l'utilisation de cet équipement.

5. Eye, hand, and foot protection must be worn when using this equipment.
6. Keep operating area clear of all persons.



WARNING: Flammable liquids can create fumes which can ignite, causing property damage or severe injury.

AVERTISSEMENT : Des liquides inflammables peuvent produire des vapeurs qui peuvent s'enflammer, causant ainsi des dommages à la propriété ou des blessures graves.

WARNING: Risk of explosion — Operate only where open flame or torch is permitted.

AVERTISSEMENT : Risque explosion - Utiliser uniquement dans des endroits où l'utilisation d'une flamme nue ou d'une torche est permise.



WARNING: Risk of fire — Do not add fuel when the product is operating or still hot.

AVERTISSEMENT : Risque d'incendie - Ne pas ajouter de carburant pendant que la machine fonctionne ou est encore chaude.

WARNING: Do not use gasoline crankcase draining or oil

containing gasoline, solvents or alcohol. Doing so will result in fire and/or explosion.

AVERTISSEMENT : Ne pas utiliser d'essence, de drainage du carter de moteur ou d'essence contenant de l'huile, de solvants ou de l'alcool. Agir de la sorte risquerait de créer un incendie et/ou une explosion.

WARNING: Risk of fire — Do not spray flammable liquids

AVERTISSEMENT : Risque d'incendie - Ne pas pulvériser de liquides inflammables.

7. Allow engine to cool for 1-2 minutes before refueling. If any fuel is spilled, make sure the area is dry before testing the spark plug or starting the engine. (Fire and/or explosion may occur if this is not done.)

Gasoline engines on mobile or portable equipment shall be refueled:

- a. outdoors;
- b. with the engine on the equipment stopped;
- c. with no source of ignition within 10 feet of the dispensing point; and

- d. with an allowance made for expansion of the fuel should the equipment be exposed to a higher ambient temperature.

In an overfilling situation, additional precautions are necessary to ensure that the situation is handled in a safe manner.

WARNING: Risk of injury. Disconnect battery ground terminal before servicing.

AVERTISSEMENT : Risque de blessures - Débrancher la borne de mise à la terre de la batterie avant de procéder à des opérations d'entretien.

8. When in use, do not place machine near flammable objects as the engine is hot.
9. Oil burning appliances shall be installed only in locations where combustible dusts and flammable gases or vapors are not present. Do not store or use gasoline near this machine.
10. Use No. 1 or No. 2 heating oil (ASTM D306) only. NEVER use gasoline in your fuel oil tank. Gasoline is more combustible than fuel oil and could result in a serious explosion. NEVER use crankcase or waste oil in your burner. Fuel unit malfunction could result from contamination.
11. Do not confuse gasoline and fuel oil tanks. Keep proper fuel in proper tank.



WARNING: Risk of injury. Hot surfaces can cause burns. Use only designated gripping areas of spray gun and wand. Do not place hands or feet on non-insulated areas of the pressure washer.

AVERTISSEMENT : Risque de blessures - Les surfaces chaudes peuvent causer des brûlures. Utiliser uniquement

les zones de prise désignées du pistolet pulvérisateur et de la lance. Ne pas placer les mains ou les pieds sur des endroits non isolés de la laveuse à pression.

12. Transport/Repair with fuel tank EMPTY or with fuel shut-off valve OFF.



CAUTION: Hot discharge fluid. Do not direct discharge stream at people or animals or severe injury or death will result.

ATTENTION : Liquide de décharge chaud. Ne pas décharger directement le jet vers des personnes ou des animaux, car cela risquerait de causer des

blessures graves ou même la mort.

WARNING: This machine produces hot water and must have insulated components attached to protect the operator.

AVERTISSEMENT : Cette machine produit de l'eau chaude et doit comporter des composants isolés attachés pour protéger l'opérateur.

- To reduce the risk of injury, close supervision is necessary when a machine is used near children. Do not allow children to operate the pressure washer. This machine must be attended during operation.



WARNING: Grip cleaning wand securely with both hands before starting. Failure to do this could result in injury from a whipping wand.

AVERTISSEMENT : Agripper la lance de nettoyage avec les deux mains avant de commencer. Le non-respect de cette consigne pourrait mener à des blessures causées par le

mouvement violent de la lance.

- Never make adjustments on machine while in operation.
- Be certain all quick coupler fittings are secured before using pressure washer.



WARNING: High pressure developed by these machines will cause personal injury or equipment damage. Keep clear of nozzle. Use caution when operating. Do not direct discharge stream at people, or severe injury or death will result.

AVERTISSEMENT : La haute pression générée par ces machines causera des lésions corporelles ou des dommages à l'équipement. Se tenir à l'écart de la buse. Faire preuve de prudence lors de l'utilisation. Ne pas décharger directement le jet vers des personnes ou des animaux, car cela risquerait de causer des blessures graves ou même la mort.



WARNING: Protect machine from freezing.

AVERTISSEMENT : Protéger la machine contre le gel.

16. To keep machine in best operating conditions, it is important you protect machine from freezing. Failure to protect machine from freezing could cause malfunction of the machine

and result in death, serious bodily injury, and/or property damage. Follow storage instructions specified in this manual.

- Inlet water must be clean fresh water and no hotter than 90°F.

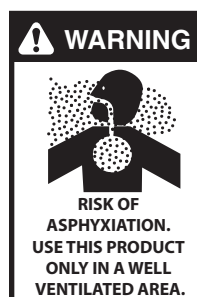

WARNING: Risk of asphyxiation. Running this product indoors can result in death due to carbon monoxide, a poisonous gas you cannot see or smell. Never operate indoors, even if windows and doors are open. Only use outdoor and far away from windows, doors, and openings or vents.

AVERTISSEMENT: Risque d'asphyxie : L'utilisation de ce produit à l'intérieur peut causer la mort par monoxyde de carbone, un gaz toxique incolore et inodore. Ne jamais utiliser à l'intérieur, même si les fenêtres et les portes sont ouvertes. Utiliser uniquement à l'extérieur et à l'écart des fenêtres, des portes et des ouvertures ou fentes de ventilation.

- Avoid installing machines in small areas or near exhaust fans. Adequate oxygen is needed for combustion or dangerous carbon monoxide will result.
- Manufacturer will not be liable for any changes made to our standard machines or any components not purchased from us.
- The best insurance against an accident is precaution and knowledge of the machine.



WARNING: Be extremely careful when using a ladder, scaffolding or any other relatively unstable location. The cleaning area should have adequate slopes and drainage to reduce the possibility of a fall due to slippery surfaces.

AVERTISSEMENT : Faire preuve d'une extrême prudence au moment d'utiliser une

échelle, des échafaudages ou toute autre surface relativement instable. La zone de nettoyage doit avoir une pente et un drainage adéquats pour réduire la possibilité d'une chute due à une surface glissante.



Follow the maintenance instructions specified in the manual.

21. Do not allow acids, caustic or abrasive fluids to pass through the pump.
22. Never run pump dry or leave spray gun closed longer than 1-2 minutes.
23. Machines with shut-off spray gun should not be operated with the spray gun in the off position for extensive periods of time as this may cause damage to the pump.
24. Protect discharge hose from vehicle traffic and sharp objects. Inspect condition of high pressure hose before using or bodily injury may result.
25. Before disconnecting discharge hose from water outlet, turn burner off and open spray gun to allow water to cool below 100° before stopping the machine. Then open the spray gun to relieve pressure. Failure to properly cool down or maintain the heating coil may result in a steam explosion.
26. Do not overreach or stand on unstable support. Keep good footing and balance at all times.
27. Do not operate this machine when fatigued or under the influence of alcohol, prescription medications, or drugs.
28. In oil burning models, use only kerosene, No. 1 home heating fuel, or diesel. If diesel is used, add a soot remover to every tankful.



WARNING: If connection is made to a potable water system, the system shall be protected against back flow.

AVERTISSEMENT: Si une connexion est établie avec un réseau d'eau potable, le réseau doit être protégé contre le retour d'eau.

Component Identification

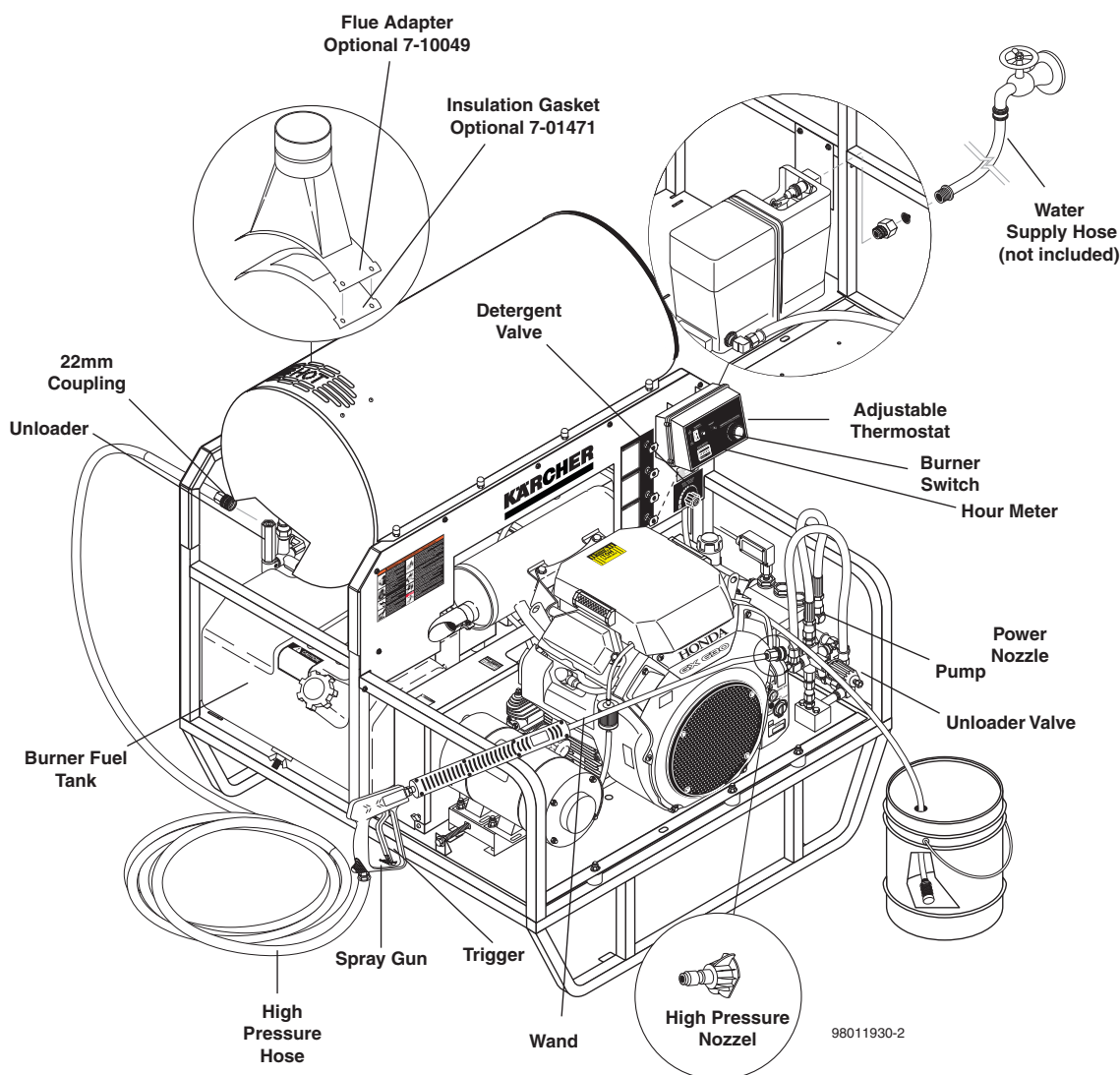

Pump — Delivers a specific gpm to the high pressure nozzle which develops pressure.

Starter Grip— Used for starting the engine manually.

Spray Gun — Controls the application of water and detergent onto cleaning surface with trigger device. Includes safety latch.

Unloader Valve— Safety device which allows pressure to be released when spray gun is closed.

High Pressure Hose — Connect one end to water pump discharge nipple and the other end to spray gun.

Adjustable Thermostat — Safety control which prevents temperatures from going above adjustable setting.

Wand — Must be connected to the spray gun.

NOTE: If trigger on spray gun is released for more than 2 minutes, warm water will discharge from pump protector onto floor. This system prevents internal pump damage.

NOTE: If flue adapter is installed, the burner assembly air adjustment must be adjusted.

Operations

Assembly Instructions

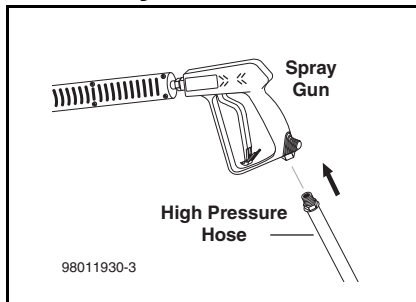

STEP 1: Attach the high pressure hose to the spray gun by threading twist connect onto spray gun inlet. Use teflon tape or sealant

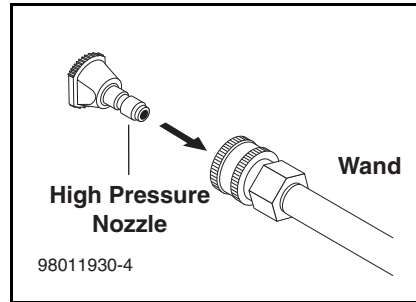

STEP 2: Remove Wand end and first place the o-ring followed by the high pressure nozzle as shown. Replace end of wand.

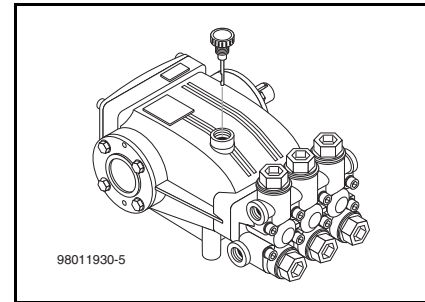

STEP 3: Remove shipping cap and install oil dipstick (Depending on type of shipping, dipstick may already be installed). Check pump oil level by using dipstick or observe oil level in oil window (if equipped). Use 30 wt. non detergent oil.

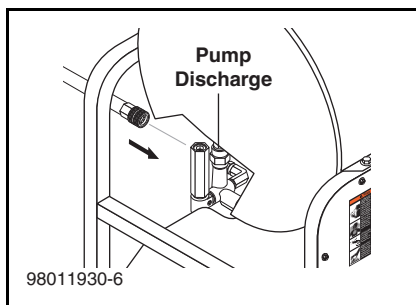

STEP 4: Connect the high pressure hose to the pump discharge fitting. Thread twist connect to discharge fitting by turning clockwise.

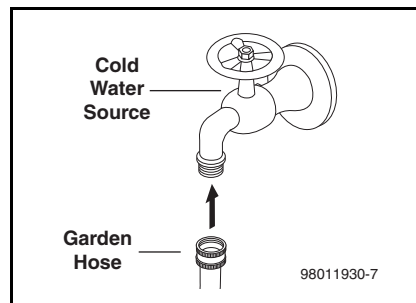

STEP 5: Connect garden hose to the cold water source.

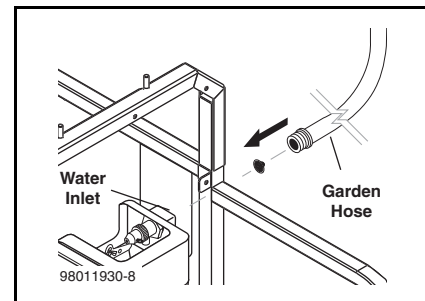

STEP 6: Check inlet filters, remove debris, then connect the garden hose to pump water inlet.

CAUTION: Do not run the pump without water or pump damage will result.

ATTENTION : Ne pas faire fonctionner la pompe sans eau ou endommager la pompe.

Battery Installation

Local purchase of battery will be the responsibility of the owner, except when the machine is purchased with a factory installed battery option (8.904-051.0). Automotive type 12 Volt Group 24 battery is recommended for placement within the weather resistant box. Follow safety and installation instructions furnished with the battery.

Red Cable is attached to battery (+) positive terminal, black cable is connected to battery (-) negative terminal.

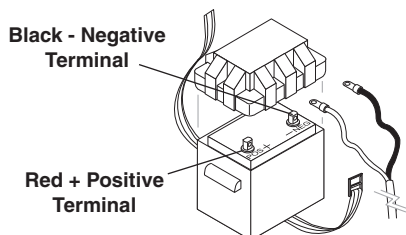

Operating Instructions

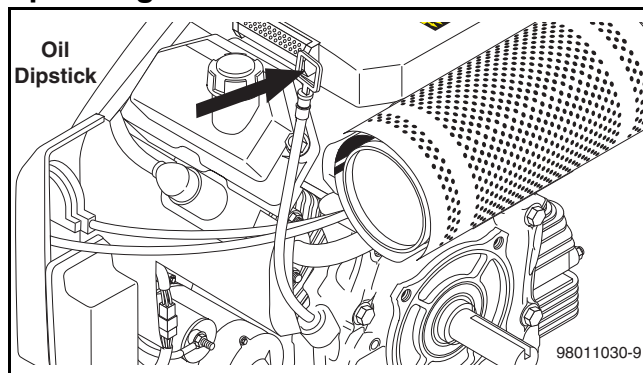

STEP 1: Check engine oil level. Oil level should be level to the fill markings on the dipstick. Be sure the machine is level when checking the oil level. (Refer to the engine's operating manual included with machine.) We recommend that the oil be changed after the first 5 hours of use, then once every 100 hours. Note: Improper oil levels will cause low oil sensor to shut off engine.

CAUTION: Do not run engine with high or low oil levels as this will cause engine damage.

ATTENTION : Ne pas faire fonctionner le moteur si le niveau d'huile est trop haut ou trop bas, car cela risquerait d'endommager le moteur.

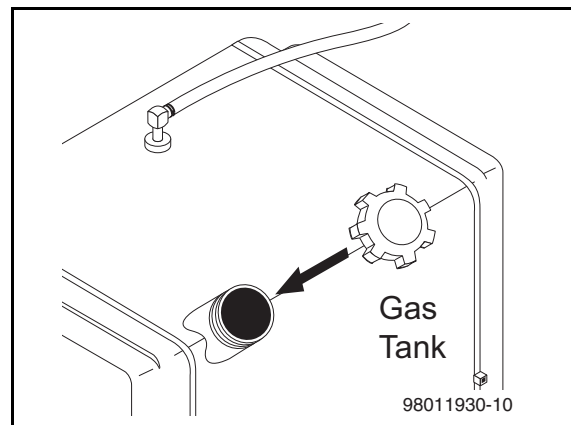

STEP 2: Fill gas tank with unleaded gasoline. Do not use leaded gasoline.

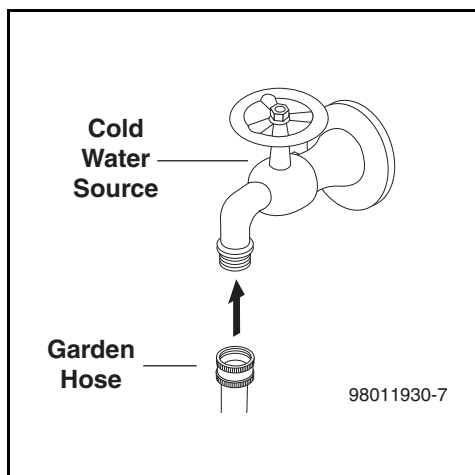

STEP 3: Connect garden hose to the cold water source and turn water on completely. Never use hot water.

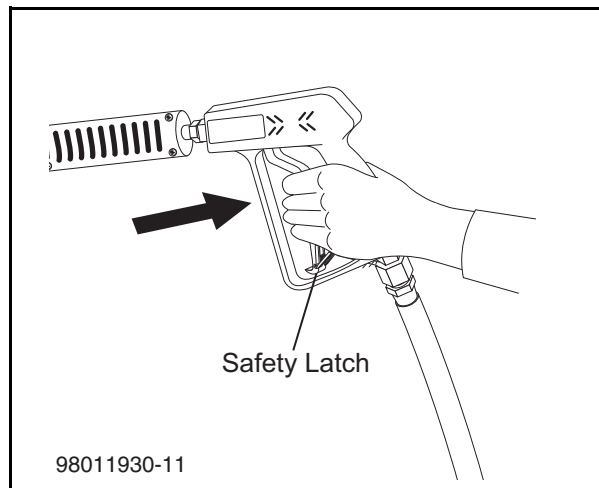

STEP 4: Before installing pressure nozzle, trigger spray gun to eliminate trapped pressure. Then run machine, allowing water to flush through the system until clear. Engage the safety latch before inserting high pressure nozzle.

Operations

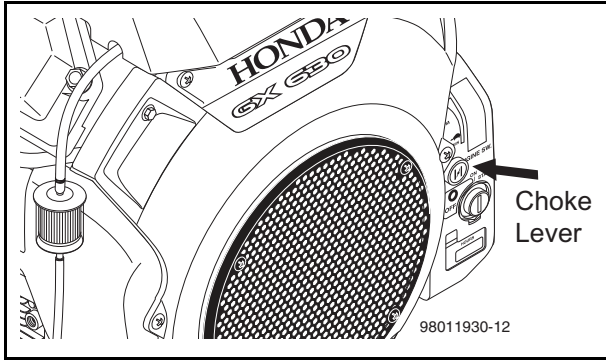

STEP 5: Pull the choke lever out to the "Choke" position (on a warm engine, leave the choke lever in the run position). Push the choke lever to the "Closed" position. To restart a warm engine, leave the choke lever in the "Open" position.

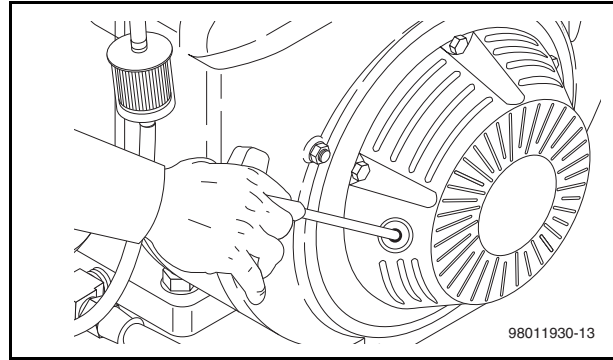

STEP 6: (Non-Electric Start Models) Pull the starter grip. If the engine fails to start after 2 pulls, squeeze the trigger gun to release pressure and repeat step. Return starter gently. After the engine warms up enough to run smoothly, move choke to run position and throttle to fast position.

WARNING: Starter cord kickback (rapid retraction) can result in bodily injury. Kickback will pull hand and arm toward engine faster than you can let go. Always relieve spray gun pressure before pulling starter cord. Pull starter cord slowly until resistance is felt, then pull rapidly

AVERTISSEMENT : Le retour du cordon de lancement (rétraction rapide) peut causer des lésions corporelles. La rétraction rapide de la corde du démarreur (recul) attire la main et le bras vers le moteur plus vite qu'il n'est possible de lâcher la corde. Toujours réduire la pression du pistolet pulvérisateur avant de tirer sur le cordon de lancement. Tirer lentement sur le cordon de lancement jusqu'à ce qu'une résistance soit sentie, puis tirer rapidement.

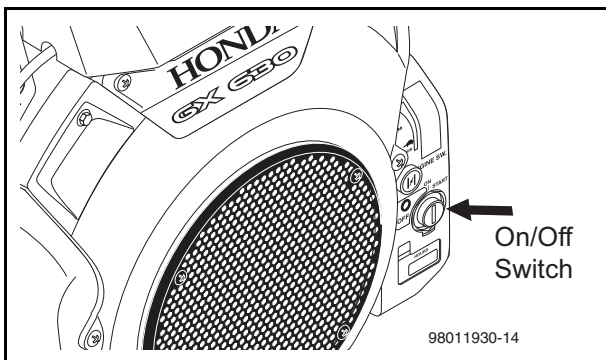

STEP 7: (Electric Start Models) Turn the engine switch to "Start" position.

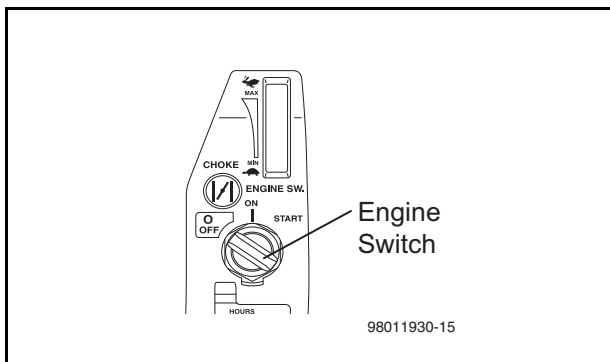

STEP 8: (Electric Start Models) Turn the key to the START position, and hold it there until the engine starts. If the engine fails to start within 5 seconds, release the key, and wait at least 10 seconds before operating the starter again.

Using the electric starter for more than 5 seconds at a time will over heat the starter motor and can damage it.

When the engine starts, release the key, allowing it to return to the ON position. If the choke knob has been pulled to the CLOSED position to start the engine, gradually push it to the OPEN position as the engine warms up.

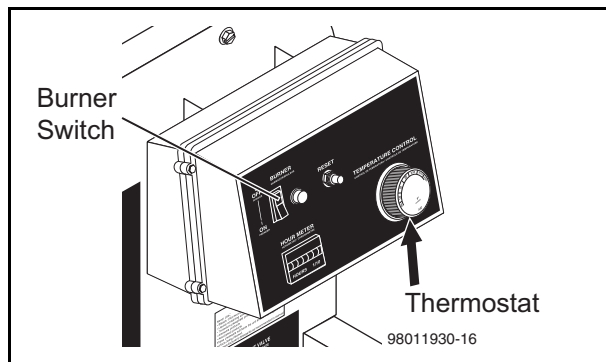

STEP 9: Turn the burner switch "ON". Turn thermostat dial to the 210° mark.

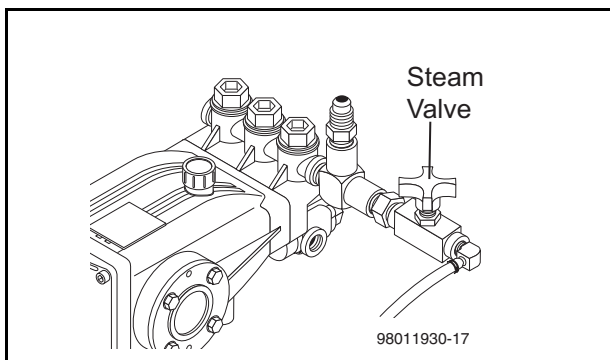

STEP 10: (Pump Steam Option)

- a. Operate machine as instructed.
- b. Open steam valve counterclockwise, which will lower pressure.
- c. Turn thermostat knob to 250°F.
- d. When steam is no longer desired, Turn steam valve clockwise and thermostat knob to 200°F.

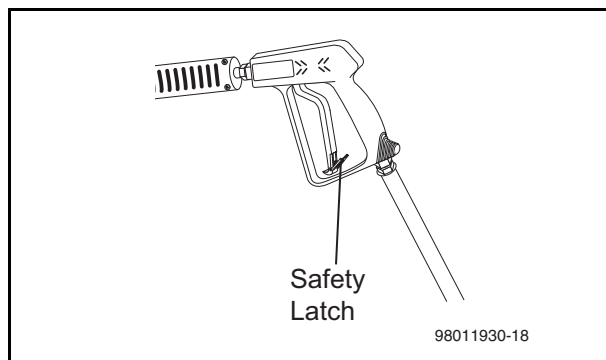

WARNING! Never replace nozzle without engaging the safety latch on the spray gun trigger.

AVERTISSEMENT : Ne jamais remplacer les buses sans d'abord mettre le dispositif de sécurité sur la détente du pistolet pulvérisateur.

Detergents & General Cleaning Techniques



WARNING: Some detergents may be harmful if inhaled or ingested, causing severe nausea, fainting or poisoning. The harmful elements may cause property damage or severe injury. Read msds before handling.

AVERTISSEMENT : Certains détergents peuvent être dangereux s'ils sont inhalés ou

ingérés, provoquant de fortes nausées, des évanouissements et l'empoisonnement. Les éléments dangereux peuvent causer des dommages à la propriété ou des blessures graves. Lire la fds avant la manipulation.

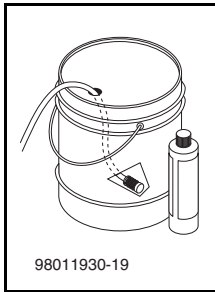

STEP 1: Use detergent designed specifically for pressure washers. Household detergents could damage the pump. Prepare detergent solution as required by the manufacturer. Fill a container with pressure washer detergent. Place the filter end of detergent suction tube into the detergent container.

STEP 2: Open detergent metering valve.

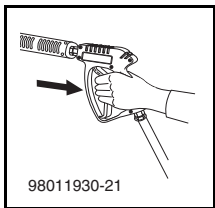
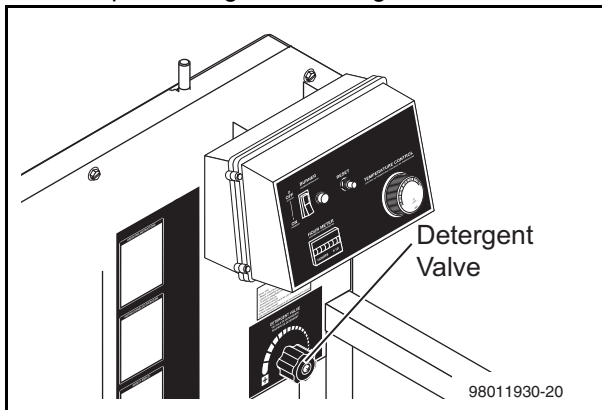

STEP 3: Detergent will be drawn into the pump and coil and discharged under pressure. Never use anything that will damage the pump and coil.

STEP 4: With the engine running, pull trigger to operate machine. Liquid detergent is drawn into the machine and mixed with water. Apply detergent to work area. Do not allow detergent to dry on surface.

IMPORTANT: You must flush the detergent from your machine after each use by placing the suction tube into a bucket of clean water and then running the pressure washer for 1-2 minutes.

Thermal Pump Protection

If you run the engine on your pressure washer for 3-5 minutes without pressing the trigger on the spray gun, circulating water in the pump can reach high temperatures. When the water reaches this temperature, the pump protector engages and cools the pump by discharging the warm water onto the ground. This thermal device prevents internal damage to the pump.

Cleaning Tips

Pre-rinse cleaning surface with fresh water. Place detergent suction tube directly into cleaning solution and apply to surface at low pressure (for best results, limit your work area to sections approximately 6 feet square and always apply detergent from bottom to top). Allow detergent to remain on surface 1-3 minutes. Do not allow detergent to dry on surface. If surface appears to be drying, simply wet down surface with fresh water. If needed, use brush to remove stubborn dirt. Rinse at high pressure from top to bottom in an even sweeping motion keeping the spray nozzle approximately 1 foot from cleaning surface. Use overlapping strokes as you clean and rinse any surface. For best surface cleaning action spray at a slight angle.

Recommendations:

- Before cleaning any surface, an inconspicuous area should be cleaned to test spray pattern and distance for maximum cleaning results.
- If painted surfaces are peeling or chipping, use extreme caution as pressure washer may remove the loose paint from the surface.
- Keep the spray nozzle a safe distance from the surface you plan to clean. High pressure wash a small area, then check the surface for damage. If no damage is found, continue to pressure washing.

CAUTION - Never use:

- Bleach, chlorine products and other corrosive chemicals
- Liquids containing solvents (i.e., paint thinner, gasoline, oils)
- Tri-sodium phosphate products
- Ammonia products
- Acid-based products

These chemicals will harm the machine and will damage the surface being cleaned.

ATTENTION : Ne jamais utiliser :

- Eau de Javel, produits à base de chlore et autres produits chimiques corrosifs
- Liquides contenant des solvants (c.-à-d. diluant à peinture, essence, huiles, etc.)
- Produits à base de tripolyphosphate de sodium
- Ammoniac ou produits à base d'acide

Rinsing

It will take a few seconds for the detergent to clear. Apply safety latch to spray gun. Remove black soap nozzle from the quick coupler. Select and install the desired high pressure nozzle.

NOTE: You can also stop detergent from flowing by simply removing detergent siphon tube from bottle.

Operations

Shutting down & Cleaning Up

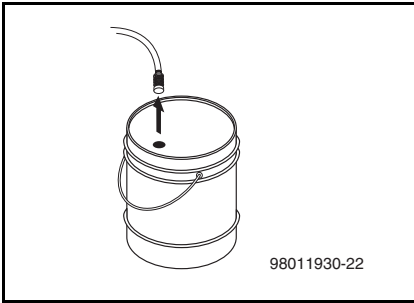

STEP 1: Remove detergent suction tube from container and insert into one gallon of fresh water. Open detergent metering valve. Pull trigger on spray gun and siphon water for one minute. Close detergent valve. Turn burner switch off and continue spraying, allowing the water to cool to below 100°F.

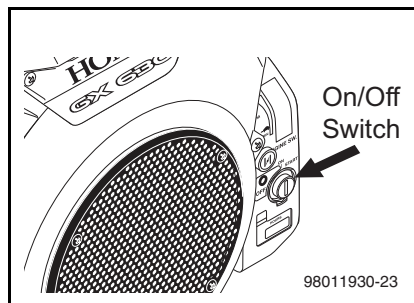

STEP 2: Turn off the engine.

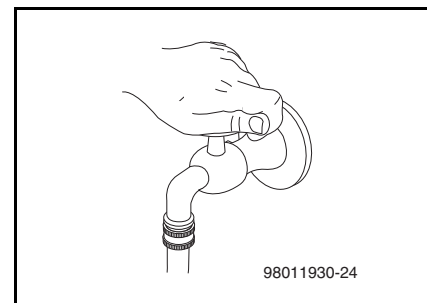

STEP 3: Turn off water supply.

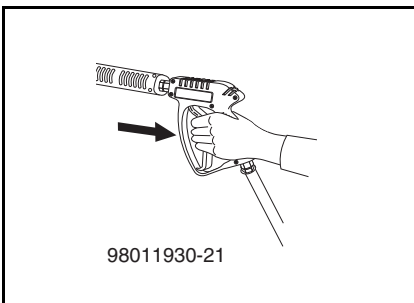

STEP 4: Press trigger to release water pressure.

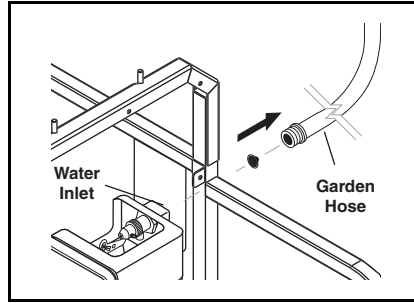

STEP 5: Disconnect the garden hose from the water inlet on the machine.

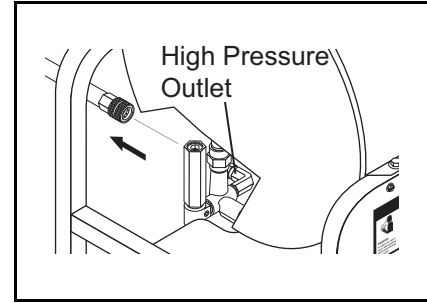

STEP 6: Disconnect the high pressure hose from high pressure outlet.



STEP 7: Engage the spray gun safety latch.

Storage

CAUTION: Always store your pressure washer in a location where the temperature will not fall below 32°F (0°C). The pump in this machine is susceptible to permanent damage if frozen. **FREEZE DAMAGE IS NOT COVERED BY WARRANTY.**

ATTENTION : Toujours entreposer la laveuse à pression dans un endroit où la température ne sera pas inférieure à 0 °C (32 °F). La pompe sur cette machine est susceptible de subir des dommages si elle est exposée au gel. **LES DOMMAGES DUS AU GEL NE SONT PAS COUVERTS PAR LA GARANTIE.**

1. Stop the pressure washer, squeeze spray gun trigger to release pressure.
2. Detach water supply hose and high pressure hose.
3. Turn on the machine for a few seconds, until remaining water exits. Turn engine off immediately.
4. Drain the gas and oil from the engine.
5. Do not allow high pressure hose to become kinked.
6. Store the machine and accessories in a room which does not reach freezing temperatures.

CAUTION: Failure to follow the above directions will result in damage to your pressure washer.

ATTENTION : Le non-respect des directives ci-dessus entraînera des dommages à la laveuse à pression.

When the pressure washer is not being operated or is being stored for more than one month, follow these instructions:

1. Replenish engine oil to upper level.
2. Drain gasoline from fuel tank, fuel line, fuel valve and carburetor.
3. Pour about one teaspoon of engine oil through the spark plug hole, pull the starter grip several times and replace the plug. Then pull the starter grip slowly until you feel increased pressure which indicates the piston is on its compression stroke and leave it in that position. This closes both the intake and exhaust valves to prevent rusting of cylinder.
4. Cover pressure washer and store in a clean, dry place that is well ventilated away from open flame or sparks.

NOTE: Use of a fuel additive, such as STA-BIL®, or an equivalent, will minimize the formulation of fuel deposits during storage. Such additives may be

added to the gasoline in the fuel tank of the engine, or to the gasoline in a storage container.

After Extended Storage

CAUTION: Prior to restarting, thaw out any possible ice from pressure washer hoses, spray gun or wand.

ATTENTION : Avant de redémarrer, faire fondre la glace se trouvant sur les boyaux, le pistolet pulvérisateur ou la lance de la laveuse à pression.

Engine Maintenance

During the winter months, rare atmospheric conditions may develop which will cause an icing condition in the carburetor. If this develops, the engine may run rough, lose power and may stall. This temporary condition can be overcome by deflecting some of the hot air from the engine over the carburetor area. **NOTE:** Refer to the engine manufacturer's manual for service and maintenance of the engine.

Preventative Maintenance

1. Check to see that water pump is properly lubricated.
2. Follow winterizing instructions to prevent freeze damage to pump and coils.
3. Always neutralize and flush detergent from system after use.
4. If water is known to have high mineral content, use a water softener in your water system, or de-scale as needed.
5. Do not allow acidic, caustic or abrasive fluids to be pumped through system.
6. Always use high grade quality cleaning products.
7. Never run pump dry for extended periods of time.
8. Use clean fuel: kerosene, No. 1 fuel oil, or diesel. Clean or replace fuel filter every 100 hours of operation. Avoid water contaminated fuel as it will damage the fuel pump.
9. If machine is operated with smoky or eye burning exhaust, coils will soot up, not letting water reach maximum operating temperature.
10. Never allow water to be sprayed on or near engine or burner assembly or any electrical component.
11. Periodically delime coils as per instructions.
12. Check to see that engine is properly lubricated.

It is advisable, periodically, to visually inspect the burner. Check air inlet to make sure it is not clogged or blocked. Wipe off any oil spills and keep equipment clean and dry.

The flow of combustion and ventilating air to the burner must not be blocked or obstructed in any manner.

The area around the pressure washer should be kept clean and free of combustible materials, gasoline and other flammable vapors and liquids.

Maintenance and Service

Unloader Valves:

Unloader valves are preset and tested at the factory before shipping. Occasional adjustment of the unloader may be necessary to maintain correct pressure.

Adjusting Unloader Valves:

Tampering with the factory setting may cause personal injury and/or property damage and will void the manufacturer's warranty.

Winterizing Procedure:

Damage due to freezing is not covered by warranty. Adhere to the following cold weather procedures whenever the washer must be stored or operated outdoors under freezing conditions.

During winter months, when temperatures drop below 32°F, protecting your machine against freezing is necessary. Store the machine in a heated room. If this is not possible then mix a 50/50 solution of anti-freeze and water in the float tank. Turn the engine on to siphon the anti-freeze mixture through the machine. If compressed air is available, an air fitting can be screwed into the float tank by removing the float tank strainer and fitting. Then inject the compressed air. Water will be blown out of the machine when the trigger on the spray gun is opened.

High Limit Hot Water Thermostat:

For safety, each machine is equipped with a temperature sensitive high limit control switch. In the event that the water should exceed its operating temperature, the high limit control will turn the burner off until the water cools then it will automatically reset itself. The thermostat sensor is located on the discharge side of the heating coil. The thermostat control dial is located on the control panel.

Pumps:

Before running the pump check the pump crankcase for a proper oil level. A proper oil level is indicated by the red dot in the sightglass or between the high and low marks on the dipstick. Use only SAE 30 non-detergent oil. Change the initial oil after the first 50 hours and then change the oil every 500 hours or every three months.

When draining oil, clean inside of crankcase to remove all impurities.

CAUTION: When operating in damp places or with high temperature fluctuations oil must be changed immediately.

ATTENTION : Lorsque l'appareil est utilisé dans des endroits humides ou où les températures fluctuent fortement, l'huile doit être changée immédiatement.

Cleaning of Coils:

In alkaline water areas, lime deposits can accumulate rapidly inside the heating coil. This growth is increased by the extreme heat build up in the coil. The best

preventative for liming conditions is to use high quality cleaning detergents. In areas where alkaline water is an extreme problem, periodic use of Coil Conditioner will remove lime and other deposits before coil becomes plugged. (See Deliming instructions for use of Coil Conditioner.)

Deliming Coils:

Periodic flushing of coils or optional float tank is recommended.

1. Fill a container with 4 gallons of water, then add 1 lb. of deliming powder. Mix thoroughly. Pour mixture into float tank.
2. Remove wand assembly from spray gun and put spray gun into float tank. Secure the trigger on the spray gun into the open position.
3. Turn engine on, allowing solution to be pumped through coils back into the float tank. The solution should be allowed to circulate 2- 4 hours or until the color changes.
4. After circulating solution, flush the entire system with fresh water. Clean out float tank and then reinstall wand assembly to spray gun.

Removal of Soot from Heating Coil:

In the heating process, fuel residue in the form of soot deposits may develop between the heating coil pipe, and block air flow which will affect burner combustion. When soot has been detected on visual observation, the soot on the coil must be washed off after following the coil removal steps (See Coil Removal section).

Fuel:

Use clean fuel oil that is not contaminated with water and debris. Replace fuel filter and drain tank every 100 hours of operation.

Use No.1 or No 2 Heating Oil (ASTM D306) only. NEVER use gasoline in your burner fuel tank. Gasoline is more combustible than fuel oil and could result in a serious explosion. NEVER use crankcase or waste oil in your burner. Fuel unit malfunction could result from contamination.

Fuel Control System:

This machine utilizes a fuel solenoid valve located on the fuel pump to control the flow of fuel to the combustion chamber. The solenoid, which is normally closed, is activated by a flow switch when water flows through it. When the operator releases the trigger on the spray gun, the flow of water through the flow switch stops, turning off the electrical current to the fuel solenoid.

The solenoid then closes, shutting off the supply of fuel to the combustion chamber. Controlling the flow of fuel in this way gives an instantaneous burn-or-no-burn situation, thereby eliminating high and low water temperatures and the combustion smoke normally associated with machines incorporating a spray gun. Periodic inspection, to insure that the fuel solenoid valve functions properly, is recommended. This can be done by operating the machine and checking to see that the burner is not firing when the spray gun is in the OFF position.

Rupture Disk:

If pressure from pump or thermal expansion should exceed safe limits, the rupture disk will burst allowing high pressure to be discharged through hose to ground. When disk ruptures it will need to be replaced. The Rupture Disk should be replaced every two years.

Fuel Pressure Adjustment:

To adjust fuel pressure, first install a pressure gage into the port just after the pump fuel exit. Turn the adjusting screw (located at the regulator port) clockwise to increase, and counterclockwise to decrease. Do not exceed 200 psi or lower the pressure below 130 PSI, when checked at the post-pump pressure port.

The fuel pressure may need to be adjusted due to altitude. For every 500 ft altitude above sea level, the boiling point of water goes down 1 °F. At high altitude environments, this boiling point change may require the heat input to be lowered so the water input does not turn to steam earlier than at the factory settings and activate the pressure sensors and pressure relief equipment when the unit is operated and much higher altitudes from factory settings or local dealer site settings. Check with your dealer before making local site fuel pressure adjustments.

Also, as ambient temperature changes seasonally, the fuel temperature in the feed tank and air temperature inlet can impact fuel flow. In more extreme temperatures, this local-site adjustment may also require different fuel nozzles for fuel inlet temperatures that are at seasonal extremes (higher or lower) in locations where the temperature changes are beyond moderate temperatures of between 40°F and 90°F. Colder temperatures will make for a thicker flow and less fine a fuel spray while hotter temperatures will make for a thinner flow a more fine spray with the same nozzle. Consider alternate nozzle configurations from the baseline factory-supplied nozzle for operating in such temperature extremes if performance is not meeting needs with air band and fuel pressure settings alone.

NOTE: When changing fuel pump, a by-pass plug must be installed in return line port or fuel pump will not prime

Burner Nozzle:

Keep the tip free of surface deposits by wiping it with a clean, solvent saturated cloth, being careful not to plug or enlarge the nozzle. For maximum efficiency, replace the nozzle each season.

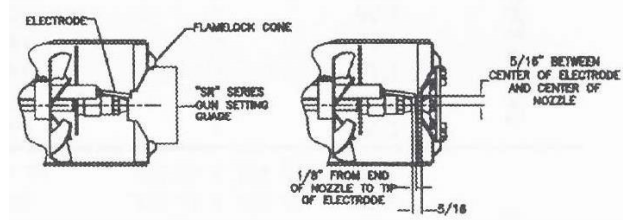

Electrode Setting

SR Series Gage

KNA Part # 8.717-379.0

Oil Burner

Burner Air Adjustment: The oil burner on this machine is preset for operation at altitudes below 500 feet. If operated at higher altitudes, it may be necessary to adjust the air band for a #1 or #2 smoke spot on the Bacharach scale.

To adjust, start machine and turn burner ON. Loosen two locking screws found on the air band and close air band until black smoke appears from burner exhaust vent. Note air band position. Next, slowly open the air band until white smoke just starts to appear. Turn air band halfway back to the previously noted position. Tighten locking screws.

For higher altitudes, the air band opening may need to be increased; for lower altitude, the air band may need to be decreased.

For higher humidity, the air band opening may need to be increased; for lower relative humidity, the air band may need to be decreased.

For higher ambient temperatures the air band opening may need to be increased; for lower ambient temperatures, the air band opening may need to be decreased.

Adjust to your operating location's environment as needed for best smoke spot and performance compliant with local, state, and federal regulations.

Caution: If white smoke appears from burner exhaust vent during start-up or operation, discontinue use and readjust air bands.

NOTE: If a flue is installed, have a professional serviceman adjust your burner for a #1 or #2 smoke spot on the Bacharach scale.

Coil Removal:

Removal of coil because of freeze breakage, or to clean soot from it can be done quickly and easily.

1. Disconnect hose from pump to inlet side of the coil.
2. Carefully disconnect the thermostat sensor making sure you do not crimp the capillary tube.
3. Remove burner assembly from combustion chamber.
4. Remove the 3-3/8" bolts from each side of coil and tank assembly (these bolts are used to fasten tank to chassis).
5. Remove fittings connected to the 1/2" pipe nipples from inlet and discharge sides of coil.
6. Remove top tank wrap, bend back insulation tabs and fold back blanket.
7. Remove bolts that hold down coil to bottom wrap.
8. Remove coil.
9. Replace or repair any insulation found to be torn or broken.

Remove insulation retainer plates.

Coil Reinstallation:

Reinstall new or cleaned coil by reversing Steps 9 through 1.

Troubleshooting

PROBLEM	POSSIBLE CAUSE	SOLUTION
LOW OPERATING PRESSURE	Faulty pressure gauge	Install new gauge.
	Insufficient water supply	Use larger supply hose; clean filter at water inlet.
	Old, worn or incorrect spray nozzle	Match nozzle number to machine and/or replace with new nozzle.
	Belt slippage	Tighten or replace; use correct belt.
	Plumbing or hose leak	Check plumbing system for leaks. Retape leaks with teflon tape.
	Faulty or misadjusted unloader valve	Adjust unloader for proper pressure. Install repair kit when needed.
	Worn packing in pump	Install new packing kit.
	Fouled or dirty inlet or discharge valves in pump	Clean inlet and discharge valves.
	Worn inlet or discharge valves	Replace with valve kit.
	Obstruction in spray nozzle	Remove obstruction.
	Leaking pressure control valve	Rebuild or replace as needed.
	Slow engine RPM	Set engine speed at proper specifications.
	Pump sucking air	Check water supply and possibility of air seepage.
	Valves sticking	Check and clean or replace if necessary.
Unloader valve seat faulty	Check and replace if necessary.	
BURNER WILL NOT LIGHT	Little or no fuel	Fill tank with fuel.
	Improper fuel or water in fuel	Drain fuel tank and fill with proper fuel.
	Clogged fuel line	Clean or replace.
	Plugged fuel filter	Replace as needed.
	Misadjusted burner air bands	Readjust air bands for clean burn.
	Little or no fuel pressure from fuel pump	Increase fuel pressure to specification and/or replace fuel pump. Test with pressure gauge.
	Faulty burner transformer	Test transformer for proper arc between contacts. Replace as needed.
	Disconnected or short in electrical wiring	All wire contacts should be clean and tight. No breaks in wire.
	Flex coupling slipping on fuel pump shaft or burner motor shaft	Replace if needed.
	On-Off switch defective	Check for electrical current reaching burner assembly with burner switch on.
	Heavy sooting on coil and burner can cause interruption of air flow and shorting of electrodes	Clean as required.
	Improper electrode setting	Check and reset according to diagram in Operator's Manual.
	Fuel not reaching combustion chamber	Check fuel pump for proper flow. Check solenoid flow switch on machines with spray gun control, for proper on-off fuel flow control.
	Clogged burner nozzle	Clean as required.

Maintenance

PROBLEM	POSSIBLE CAUSE	SOLUTION
BURNER WILL NOT LIGHT	Thermostat faulty or slow engine speed	Increase engine RPM to increase voltage.
	Flow switch malfunction	Remove, test for continuity and replace as needed.
	Flow solenoid malfunction	Replace if needed.
FLUCTUATING PRESSURE	Valves worn	Check and replace if necessary.
	Blockage in valve	Check and replace if necessary.
	Pump sucking air	Check water supply and air seepage at joints in suction line.
	Worn piston packing	Check and replace if necessary.
MACHINE SMOKES WHILE BURNER UNIT IS RUNNING OR UNIT SMOKES AT COLD-START ONLY WHEN BURNER IS OFF	Improper fuel or water in fuel	Drain tank and replace contaminated fuel
	Improper air adjustment	Readjust air bands on burner assembly
	Fuel pressure is low <140 psi for burner	Adjust fuel pump pressure to specifications
	Burner nozzle is plugged or dirty	Replace nozzle. Check parts breakdown for nozzle size
	Burner nozzle spray pattern is faulty	Replace nozzle. Check parts breakdown for nozzle size
	Heavy accumulation of soot on coils and burner assembly	Remove coils and burner assembly, clean thoroughly Call local dealer
	Misaligned electrode setting	Realign electrodes to specifications
	Obstruction in smoke stack	Check for insulation blockage or other foreign objects
	Low engine RPM	Increase RPM to correct specs. See serial plate
	Fuel Pressure is too high for clean burn (fuel PSI above 140 and below 200) and smokes when burner is off	Reduce fuel pressure PSI/Increase air band set for cleaner without max water heat loss
LOW WATER TEMPERATURE	Improper fuel or water in fuel	Replace with clean and proper fuel.
	Low fuel pressure	Increase fuel pressure.
	Weak fuel pump	Check fuel pump pressure. Replace pump if needed.
	Fuel filter partially clogged	Replace as needed.
	Soot build-up on coils not allowing heat transfer	Clean coils.
	Improper burner nozzle	See specifications.
WATER TEMPERATURE TOO HOT	Incoming water to machine warm or hot	Lower incoming water temperature.
	Fuel pump pressure too high	See specifications for proper fuel pressure.
	Fuel pump defective	Replace fuel pump.
RELIEF VALVE LEAKS WATER	Relief valve defective	Replace or repair

PROBLEM	POSSIBLE CAUSE	SOLUTION
WATER TEMPERATURE TOO HOT	Detergent line sucking air	Tighten all clamps. Check detergent lines for holes.
	Defective temperature switch	Replace.
	Incorrect fuel nozzle size	See specifications for proper fuel nozzle.
	Insufficient water supplied	Check water G.P.M. to machine.
	Restricted water flow	Check nozzle for obstruction, proper size.
PUMP NOISY	Air in suction line	Check water supply and connections on suction line.
	Broken or weak inlet or discharge valve springs	Check and replace if necessary.
	Excessive matter in valves	Check and clean if necessary.
	Worn bearings	Check and replace if necessary.
PRESENCE OF WATER IN OIL	Oil seal worn	Check and replace if necessary.
	High humidity in air	Check and change oil twice as often.
WATER DRIPPING FROM UNDER PUMP	Piston packing worn	Check and replace if necessary.
	O-Ring plunger retainer worn	Check and replace if necessary.
	Cracked piston	Check and replace if necessary.
	Pump protector	Lower water supply pressure. Do not run with spray gun closed longer than 2 minutes
OIL DRIPPING	Oil seal worn	Check and replace if necessary.
EXCESSIVE VIBRATION IN DELIVERY LINE	Irregular functioning of the valves	Check and replace if necessary.
DETERGENT NOT DRAWING	Air leak	Tighten all clamps. Check detergent lines for holes.
	Restrictor in float tank is missing	Replace restrictor. Check for proper orifice in restrictor.
	Filter screen on detergent suction hose plugged	Clean or replace.
	Dried up detergent plugging metering valve	Disassemble and clean thoroughly.
	High viscosity of detergent	Dilute detergent to specifications.
	Hole in detergent line(s)	Repair hole.
	Low detergent level	Add detergent, if needed.
PUMP RUNNING NORMALLY BUT PRESSURE LOW ON INSTALLATION	Pump sucking air	Check water supply and possibility of air seepage.
	Valves sticking	Check and clean or replace if necessary.
	Nozzle incorrectly sized	Check and replace if necessary (See serial plate for proper size).
	Unloader valve seat faulty	Check and replace if necessary.
	Worn piston packing	Check and replace if necessary.
BURNER MOTOR WILL NOT RUN	Fuel pump seized	Replace fuel pump.
	Burner fan loose or misaligned	Position correctly, tighten set screw.
	Defective control switch	Replace switch.
	Loose wire	Check and replace or tighten wiring.
	Defective burner motor	Replace motor.

Parts

SSG

SSG-403037E - 1.110-579.0

SSG-503027E - 1.110-580.0

SSG-503027E/G - 1.110-581.0

SSG-503537E - 1.110-582.0

SSG-503537E/G - 1.110-583.0

SSG-603537E - 1.110-584.0

SSG-603537E/G - 1.110-585.0

SSG-503537E/G - 1.110-603.0

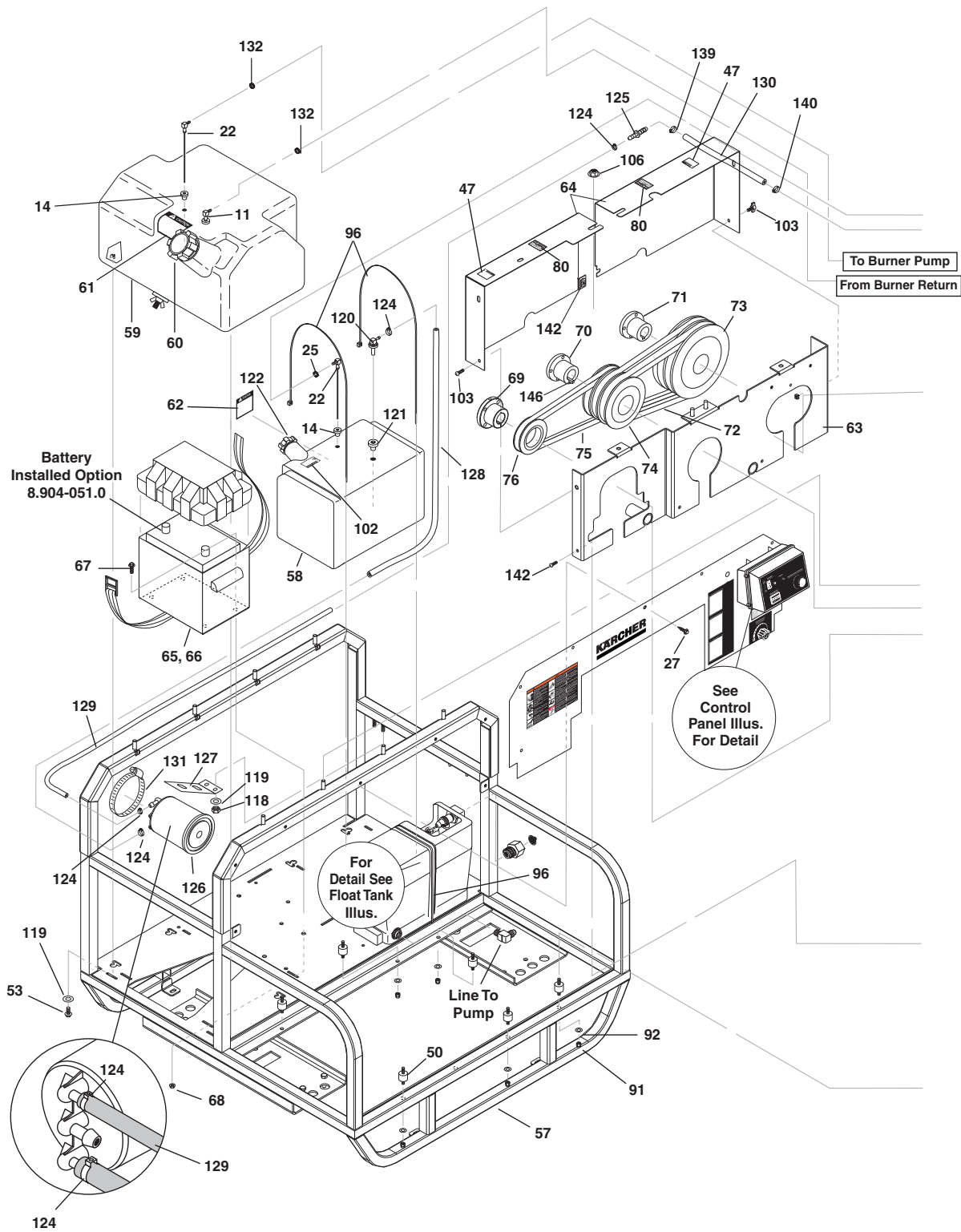

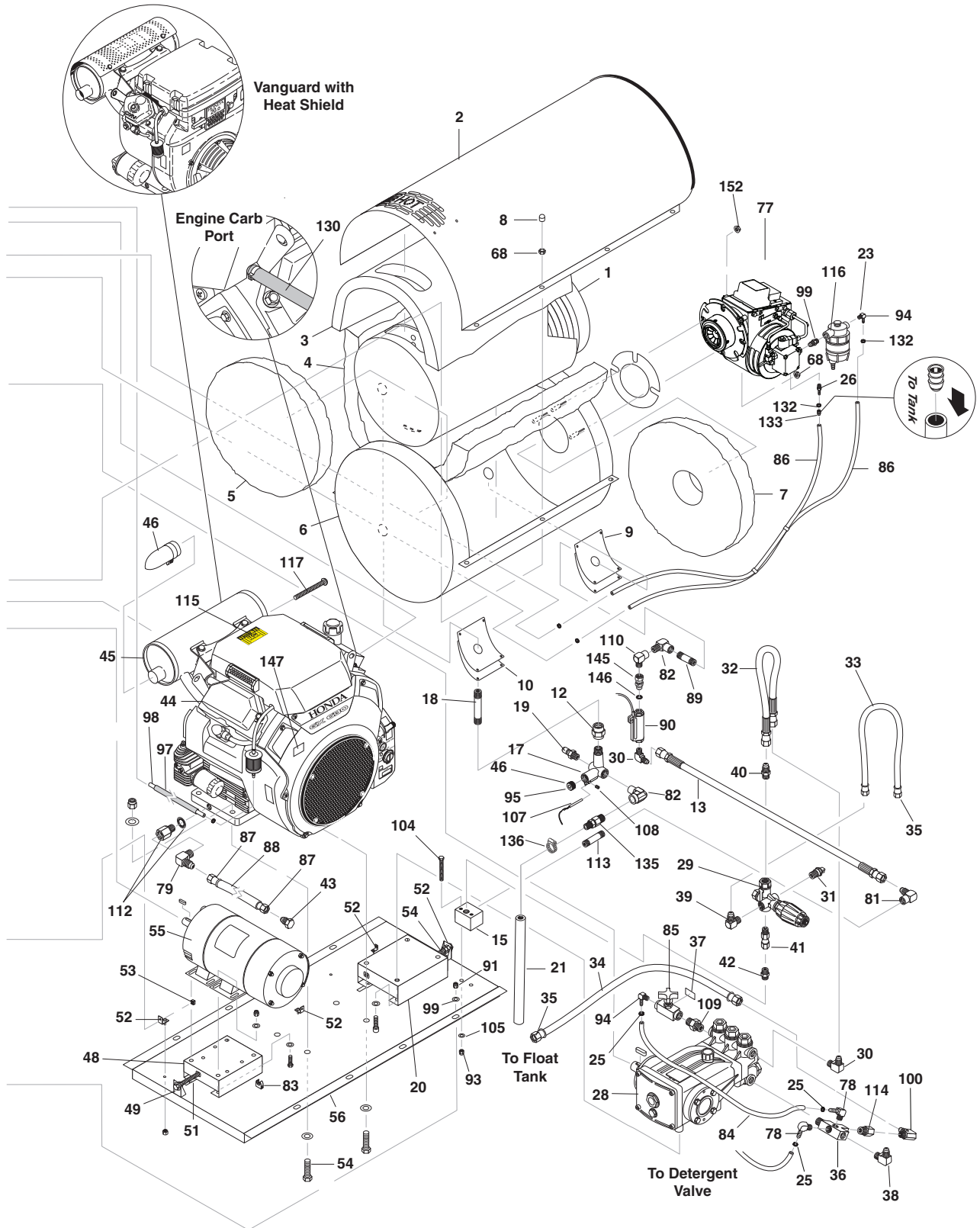

SSG Parts List

REF	PART NO.	QTY	DESCRIPTION	NOTES
1	9.803-014.0	1	COIL, RODLESS	
2	9.803-005.0	1	TOP WRAP, SS	
-	9.802-071.0	2 ft.	TRIM	NOT SHOWN
3	9.802-902.0	1	INSULATION/BLANKET, DIE CUT 28" X 24"	
4	9.802-896.0	1	INSULATION/BLANKET, NO FOIL, 24" X 57"	
5	9.802-883.0	1	INSULATION, BURNER HEAD, NO HOLE	
6	9.803-006.0	1	WELDMENT, BOTTOM WRAP	
-	9.802-727.0	2	BOLT, 3/8" - 16 X 1-3/4"	NOT SHOWN
-	9.802-807.0	2	WASHER, 3/8", SAE, FLAT ZINC	NOT SHOWN
7	9.802-894.0	1	INSULATION, BURNER HEAD, W/HOLE	
8	8.750-435.0	8	CAP, BLACK VINYL .364 X 1/2	
9	8.933-009.0	2	GASKET, BURNER PLATE	
10	9.803-132.0	2	PLATE, INSULATION RETAINER	
-	9.802-797.0	8	SCREW, SS #10, HH TEK	NOT SHOWN
11	9.802-054.0	1	ELBOW, ZINC	
12	8.706-141.0	1	COUPLING, 1/2" STEEL PIPE	
13	8.918-428.0	1	HOSE 3/8" X 48", 2 WIRE PRESSURE	
14	9.802-053.0	2	BUSHING, RUBBER	1.110-579.0
-	9.802-053.0	3	BUSHING, RUBBER	ALL MODELS EXCEPT 1.110-579.0
15	9.802-869.0	1	BLOCK, UNLOADER, 1/2" X 1/2", BRASS	
16	8.706-944.0	1	HOSE BARB, 3/8" BARB, ML PIPE	
17	8.757-240.0	1	MANIFOLD, COIL OUTLET DISCHARGE, W/TAG	
18	8.757-231.0	1	NIPPLE, 1/2" X 3", TAGGED	
19	9.802-171.0	1	NIPPLE, 3/8" X 3/8" NPT, MALE	
20	9.803-013.0	1	RAIL, PUMP	
-	9.802-099.0	3	WASHER, SNUBBING	
-	9.802-779.0	3	NUT, 3/8", ESNA, NC	
21	9.802-260.0	2 ft	HOSE 5/8"	
22	9.803-531.0	2	DIPTUBE, PLASTIC, 10.00" LONG	ALL MODELS EXCEPT 1.110-579.0
-	9.803-531.0	1	DIPTUBE, PLASTIC, 10.00" LONG	1.110-579.0
23	8.725-306.0	1	FILTER, FUEL OIL/H2O SEPARATOR	
24	8.756-874.0	1	ADAPTER, G 1/2-14 X 1/2-14 NPTF	
25	6.390-126.0	5	CLAMP, HOSE	
26	8.757-199.0	1	HOSE BARB, 1/4" BARB x 1/4" M-NPTF, BRASS	
27	8.750-246.0	7	SCREW, 1/4" X 1/2" NC, WHIZ LOC BLK CAD	
28	-	-	PUMP	SEE SPECIFICATION PAGES
29	8.750-299.0	1	UNLOADER VRT3, 8 GPM @ 4500 PSI	
30	8.757-616.0	2	ADAPTER 1/2 JIC (M) X 3/8 BSPP (M) 90°	
31	8.707-254.0	1	PUMP PROTECTOR, 3/8" FNPT	
32	8.918-421.0	1	HOSE, PRESSURE, 3/8" X 16"	
33	9.802-259.0	17"	HOSE, 1/2" PUSH ON	
34	9.802-261.0	2 ft.	HOSE, 3/4" PUSH ON	
35	9.802-151.0	4	SWIVEL, 1/2" JIC, PUSH ON	

REF	PART NO.	QTY	DESCRIPTION	NOTES
36	8.757-710.0	1	TEE STREET BRASS 1/2" W/ 2 HOLES 1/8"	
37	8.758-414.0	1	LABEL, OPEN FOR STEAM	
38	8.757-391.0	1	ELBOW, 1/2" M SAE x 1/2" NPTF (M)	
39	8.757-262.0	1	ELBOW, 1/2" SAE 45° X 3/8" NPTF(M) BRASS	
40	8.757-655.0	1	ADAPTER STEEL 1/2" JIC X 3/8" NPTF(M)	
41	8.757-656.0	1	ADAPTER SWIVEL STEEL 1/2 JICX3/8 NPTF(M)	
42	8.757-508.0	1	ADAPTER, 3/4"-16SAE X 1/2" NPTF(M),STEEL	
43	9.802-126.0	1	PLUG, 1/2" FLARE	ALL EXCEPT 1.110-579.0
-	9.802-125.0	1	PLUG, 1/4" MJIC	1.110-579.0
44	-	-	ENGINE, SEE SPECIFICATION PAGES	
45	8.750-497.0		MUFFLER, HONDA, GX630/GX660,RIGHT 1	HONDA
-	8.739-597.0	2	BOLT, FLANGE, M8 X 20	HONDA NOT SHOWN
-	9.802-672.0	1	MUFFLER	VANGUARD NOT SHOWN
-	9.802-830.0	4	SCREW, HH, 1/4" - 20 X 1/2"	VANGUARD NOT SHOWN
-	9.802-754.0	5	SCREW, HH, WL, 1/4" - 20 X 1/2"	VANGUARD NOT SHOWN
-	9.802-867.0	1	MUFFLER GUARD	VANGUARD NOT SHOWN
-	9.802-868.0	2	BRACE	VANGUARD NOT SHOWN
-	9.803-011.0	1	SHIELD, HEAT	VANGUARD NOT SHOWN
-	9.802-775.0	3	NUT, 1/4" FLANGE, ZINC	VANGUARD NOT SHOWN
-	9.802-794.0	2	NUT, CAGE, 1/4" X 12 GAUGE	VANGUARD NOT SHOWN
46	8.915-387.0	1	DEFLECTOR, EXHAUST 1-3/8"	HONDA
-	9.802-798.0	1	SCREW, #10 - 1/2" TEK, HH, SS, 1-3/8" DEFLECTOR	HONDA NOT SHOWN
47	8.758-329.0	2	LABEL, WARNING EXPOSED PULLEYS	(581.0, 583.0, 585.0, 603.0)
-	8.758-329.0	1	LABEL, WARNING EXPOSED PULLEYS	(579.0, 580.0, 582.0, 584.0)
48	9.803-004.0	1	PUMP/RAIL GENERATOR	GENERATOR UNITS ONLY
-	9.802-099.0	3	WASHER, SNUBBING	GENERATOR UNITS ONLY
-	9.802-779.0	3	NUT, 3/8", ESNA, NC	GENERATOR UNITS ONLY
49	9.803-009.0	1	BRACKET, BELT TENSION	
-	9.803-009.0	2	BRACKET, BELT TENSION	W/GENERATOR NOT SHOWN
-	9.802-776.0	2	NUT, 5/16", ESNA, NC	NOT SHOWN
-	9.802-776.0	4	NUT, 5/16", ESNA, NC	W/GENERATOR NOT SHOWN
-	9.802-710.0	2	BOLT, 5/16", NC 2	NOT SHOWN

SSG Parts List

REF	PART NO.	QTY	DESCRIPTION	NOTES
-	9.802-710.0	4	BOLT, 5/16", NC 2	W/GENERATOR NOT SHOWN
-	9.802-804.0	2	WASHER, 5/16", FLAT	NOT SHOWN
-	9.802-804.0	4	WASHER, 5/16", FLAT	W/GENERATOR NOT SHOWN
50	9.802-060.0	6	MOUNT, RUBBER	
51	9.802-733.0	1	BOLT, 3/8" X 3-1/2" SAE	
-	9.802-733.0	2	BOLT, 3/8" X 3-1/2" SAE	W/GENERATOR
-	9.802-789.0	1	NUT, 3/8" HEX, NC	NOT SHOWN
-	9.802-789.0	2	NUT, 3/8" HEX, NC	W/GENERATOR NOT SHOWN
-	9.802-807.0	2	WASHER, 3/8", SAE, FLAT	NOT SHOWN
-	9.802-807.0	4	WASHER, 3/8", SAE, FLAT	W/GENERATOR NOT SHOWN
-	9.802-814.0	1	WASHER, 3/8" SPLIT RING LOCK, ZINC	NOT SHOWN
-	9.802-814.0	2	WASHER, 3/8" SPLIT RING LOCK, ZINC	W/GENERATOR NOT SHOWN
52	9.802-872.0	3	TAB, BELT GUARD	
-	9.802-753.0	3	SCREW, 1/4-20 x 3/4" WHIZ LOC	NOT SHOWN (579.0, 580.0, 582.0, 584.0)
-	9.802-773.0	3	Nut 1/4-20 ESNA NC	(581.0, 583.0, 585.0, & 603.0)
-	9.802-802.0	3	WASHER, 1/4" FLAT SAE ZINC	NOT SHOWN (581.0, 583.0, 585.0, & 603.0)
-	8.925-562.0	3	BRACKET ASSEMBLY MOUNT SSG/HDS	W/GENERATOR
-	9.802-794.0	6	NUT, CAGE, 1/4" X 12 GA	NOT SHOWN (579.0, 580.0, 582.0, 584.0)
53	9.802-754.0	4	SCREW, 1/4" 20 X 1/2" HH, WL	
54	9.802-728.0	4	BOLT, 3/8" X 2" NC HH	HONDA
-	9.802-716.0	4	BOLT, 5/16" X 2" NC, HH	VANGUARD
-	9.802-807.0	8	WASHER, 3/8" SAE, FLAT	NOT SHOWN HONDA
-	9.802-779.0	4	NUT, 3/8" ESNA, NC	NOT SHOWN HONDA
-	9.802-776.0	4	NUT, 5/16" ESNA, NC	NOT SHOWN VANGUARD
-	8.718-980.0	8	WASHER, 5/16" FLAT, SAE (780452)	NOT SHOWN VANGUARD
55	8.757-639.0	1	GENERATOR, TB2400	(581.0, 583.0, 585.0, & 603.0)
-	8.752-150.0	1	CORD, MOLDED	NOT SHOWN W/GENERATOR
56	9.802-999.0	1	WELDMENT, SUB-FRAME	
57	8.928-242.0	1	ASSY, FRAME, SUPER SKID	
-	8.928-306.0	1	ASSY, FRAME, SUPER SKID	1.110-603.0
58	8.752-915.0	1	FUEL TANK, 7.25 GALLON (ENGINE)	ALL EXCEPT 1.110-579.0
59	8.706-615.0	1	FUEL TANK, 8 GALLON (BURNER)	
60	9.802-089.0	1	CAP, FUEL, PLASTIC	
61	8.758-341.0	1	LABEL DIESEL BLACK ON YELLOW	
62	8.758-350.0	1	LABEL THIS TANK FOR GAS ONLY	

REF	PART NO.	QTY	DESCRIPTION	NOTES
63	8.925-563.0	1	BELT GUARD PLATE ASSEMBLY MILD STEEL HDS	(581.0, 583.0 585.0, 603.0)
-	9.803-002.0	1	WELDMENT, FACE PLATE, SHORT, BLACK	1.110-579.0, 1.110-580.0, 1.110-582.0, 1.110-584.0
64	8.925-564.0	1	BELT GUARD PUMP MILD STEEL SSG/HDS	(581.0, 583.0 585.0, 603.0)
-	8.925-567.0	1	BELT GUARD ASSEMBLY GEN SSG/HDS	(581.0, 583.0 585.0, 603.0)
-	9.803-001.0	1	WELDMENT, BELT GUARD, SHORT, BLACK	1.110-580.0, 1.110-582.0, 1.110-584.0
-	9.803-015.0	1	WELDMENT, BELT GUARD, SHORT, BLACK, W/O RELIEF	1.110-579.0
65	9.802-077.0	1	BATTERY BOX, LARGE	
66	9.802-076.0	1	PLATE, BATTERY BOX, LARGE	
67	9.802-767.0	4	SCREW, 3/8" X 3/4" HH NC WHIZ LOC	
68	9.802-781.0	13	NUT, 3/8", FLANGE WHIZ LOC	
69	-	1	GENERATOR BUSHING	GENERATOR SEE SPECIFICATION PAGES
70	-	1	ENGINE BUSHING	SEE SPECIFICATION PAGES
71	-	1	PUMP BUSHING	SEE SPECIFICATION PAGES
72	-	-	BELT, PUMP	SEE SPECIFICATION PAGES
73	-	-	PULLEY, PUMP	SEE SPECIFICATION PAGES
74	-	-	PULLEY, ENGINE	SEE SPECIFICATION PAGES
75	-	-	BELT, GENERATOR	SEE SPECIFICATION PAGES
76	-	-	PULLEY, GENERATOR	SEE SPECIFICATION PAGES
77	-	-	BURNER ASSEMBLY	SEE SPECIFICATION PAGES
-	9.802-519.0	1	STRAIN RELIEF, 1/2"	NOT SHOWN
78	8.757-204.0	2	HOSE BARB, 1/4" BARB X 1/8" M-NPTF, 90°	
79	8.757-509.0	1	ELBOW, 3/4"-16 SAE X 3/8" NPTF(M), STEEL	ALL MODELS EXCEPT 1.110-579.0
-	9.802-154.0	1	PLUG, PUSH-ON, OIL DRAIN	1.110-579.0
80	8.758-328.0	2	LABEL HOT/CALIENTE W/ARROWS	(581.0, 583.0, 585.0, 603.0)
-	8.758-328.0	1	LABEL HOT/CALIENTE W/ARROWS	(579.0, 580.0, 582.0, 584.0)
81	8.757-363.0	1	ELBOW, 90°, 3/4-16 JIC X 1/2 NPTF (F) 90	
82	8.757-239.0	2	ELBOW, 3/8" MPT X 1/2" FPT ST, W/ TAG	
83	9.802-203.0	1	CLAMP, 1/2" RO-CLIP	ALL EXCEPT 1.110-579.0
84	9.802-254.0	20"	HOSE, 1/4" PUSH-ON	
85	9.802-187.0	1	VALVE, FLOW CONTROL W/METERING	
86	9.802-254.0	2	HOSE, 1/4" PUSH-ON, FUEL LINE (60")	
87	9.802-151.0	2	SWIVEL, 1/2" JIC FEMALE ALL EXCEPT	ALL EXCEPT 1.110-579.0
-	9.802-153.0	1	SWIVEL, 1/4" JIC FEM, PUSH-ON	(579.0)
88	9.802-259.0	12"	HOSE, 1/2" PUSH-ON	
-	9.802-254.0	12"	HOSE, 1/4" PUSH-ON, /FT	(579.0)
89	8.757-405.0	1	NIPPLE, 1/2" X 2-1/2", W/SLNT	
90	8.933-006.0	1	SWITCH, MV60	

SSG Parts List

REF	PART NO.	QTY	DESCRIPTION	NOTES
91	9.802-776.0	12	NUT, 5/16", ESNA, NC	
92	8.718-980.0	12	WASHER, 5/16" FLAT, SAE (780452)	
93	9.802-779.0	2	NUT, 3/8" ESNA, NC	
94	8.757-205.0	1	HOSE BARB, 1/4" BARB x 1/4" M-NPTF, 90°	
95	8.757-211.0	1	SEAL, BONDED, BSPP, 3/8" (-06)	
96	9.802-512.0	2	CABLE, TY, 48"	
97	9.802-587.0	30"	INSULATION, 1/2" FIBER SLEEVING	
98	9.802-254.0	60"	FUEL LINE, 1/4" X LO PERM	(582.0, 583.0, 584.0, 585.0, 603.0)
-	9.802-254.0	72"	FUEL LINE, 1/4" X LO PERM	(580.0, 581.0)
99	8.757-673.0	1	ADAPTER SWIVEL STEEL 1/4 JICX1/4 NPTF(M)	
100	8.757-202.0	1	ELBOW, 3/4" 45° SAE X 1/2" M-NPTF, BRASS	
102	8.758-346.0	1	LABEL DANGER COOL ENGINE	
103	8.750-246.0	4	SCREW, 1/4" X 1/2" WHIZ LOC	
104	9.802-730.0	2	BOLT, 3/8" X 2-1/2" ZINC	
105	9.802-807.0	2	WASHER, 3/8", SAE, FLAT	
106	9.802-778.0	2	NUT, 5/16" WHIZ LOC FLANGE	(581.0, 583.0, 585.0, 603.0)
107	8.750-099.0	1	THERMOSTAT 302°F	
108	9.196-012.0	1	SCREW, 10-24 X 1/4"	
109	8.757-774.0	1	ADAPTER 3/8 BSPP (M) X 1/4 NPTF (M)	
110	9.802-042.0	1	ELBOW, 1/2 JIC X 3/8 FEM, 90DGR, ST	
111	8.757-241.0	1	PLUG, 3/8" ALLEN COUNTER SUNK, W/TAG	
112	8.750-737.0	1	ADAPTER, HONDA, M20-1.5 X 3/8 " FPT	(582.0, 583.0, 584.0, 585.0, 603.0)
113	8.757-232.0	1	NIPPLE, 1/2" X 4", TAGGED	
114	8.757-193.0	1	ADAPTER, 1/2" F-NPTF x 1/2" M-NPTF, BRASS	
115	8.758-328.0	1	LABEL HOT/CALIENTE W/ARROWS	
116	8.757-674.0	1	Adapter steel 1/4 JIC x 1/4 NPTF (M)	
117	8.718-781.0	1	SCREW, PAN HEAD	(582.0, 583.0, 584.0, 585.0)
118	9.802-775.0	2	NUT, 1/4" FLANGE, ZN	ALL MODELS EXCEPT (579.0)
119	9.802-802.0	4	WASHER, 1/4" FLAT, SAE ZINC	ALL MODELS EXCEPT (579.0)
120	8.751-059.0	1	VENT, REMOTE ASSEMBLY, CARB	ALL MODELS EXCEPT (579.0)
121	8.751-215.0	1	GROMMET REMOTE VENT, KELCH	ALL MODELS EXCEPT (579.0)
122	8.751-057.0	1	GAS CAP, W/GAUGE & TETHER	ALL MODELS EXCEPT (579.0)
123	9.802-753.0	3	SCREW, 1/4-20 x 3/4" WHIZ LOC	
124	8.753-066.0	4	CLAMP, 1 EAR, #7	
125	8.753-270.0	2	REDUCER, CONNECTOR 1/4" X 3/8"	HONDA
-	8.753-269.0	1	REDUCER, CONNECTOR 1/4 X 2/16"	VANGUARD NOT SHOWN
126	8.751-380.0	1	CARBON CANISTER, 850CC	ALL MODELSEXCEPT (579.0)
127	8.922-633.0	1	BRKT, 850CC CANISTER MOUNT, WRINKLE BLACK	ALL MODELSEXCEPT (579.0)

REF	PART NO.	QTY	DESCRIPTION	NOTES
128	9.802-254.0	12"	HOSE, 1/4" PUSH-ON	ALL MODELSEXCEPT (579.0)
129	9.802-254.0	52"	HOSE, 1/4" PUSH-ON	ALL MODELSEXCEPT (579.0)
130	8.711-785.0	6"	HOSE, 3/8" PUSH-ON	(582.0, 583.0, 584.0, 585.0)
131	8.752-918.0	1	CLAMP, HOSE, #64	ALL MODELS EXCEPT (579.0)
132	8.709-069.0	4	CLAMP, SCREW, 5/16" W , 1/4"-5/8" D, SS	
133	8.754-911.0	1	CHECK VALVE, 1 WAY, 1/4" BARB	
134	9.804-615.0	1	COVER, BATTERY TERMINAL, RED	
135	8.707-381.0	1	RUPTURE DISC ASSY, 8500#	
136	9.803-559.0	1	CLAMP, SCREW, 9/16" W, 1-1/4" OD, SS	
137	8.925-529.0	1	ADAPTER PLATE TB2400 MILD STEEL PGHW	
138	9.802-713.0	2	BOLT, 5/16" X 1-1/2", NC HH(612975)	
139	8.753-065.0	1	CLAMP, 1 EAR, 15.7MM- 18.5MM (#10)	(582.0, 583.0, 584.0, 585.0, 603.0)
140	8.753-066.0	1	CLAMP, 1 EAR, 12.6MM - 14.5MM (#7)	(580.0, 581.0)
141	9.802-779.0	4	NUT, 3/8", ESNA, NC	
142	9.802-753.0	4	SCREW, 1/4-20 X 3/4" WHIZ LOC	(581.0, 583.0, 585.0, 603.0)
-	9.802-753.0	3	SCREW, 1/4-20 X 3/4" WHIZ LOC	NOT SHOWN (579.0, 580.0, 582.0, 584.0)
143	9.802-720.0	4	BOLT, 3/8" X 1", NC HH	
144	9.802-710.0	1	SCREW 5/16" X 1" NC	
145	8.757-364.0	1	ADAPTER, 3/4-16 (F) JIC X G 3/8-19 (M)	
146	9.802-673.0	1	KEY, SHAFT, 16 HP VANGUARD	(579.0, 580.0, 582.0, 584.0)
-	9.802-959.0	1	KEY, 0.247 SQR X 2.125"	(581.0, 583.0, 585.0, 603.0)
147	8.758-377.0	1	LABEL, MAINTAIN ENGINE SPEED	(580.0, 581.0)
-	8.758-356.0	1	LABEL, RPM FACTORY SET	(579.0, 582.0, 583.0, 584.0, 585.0, 603.0)
148	9.802-771.0	1	SCREW, 10/32" X 3/4", BH SOC CS	
149	9.802-695.0	1	NUT, 10/32" KEPS	
150	9.802-701.0	2	BOLT 1/4-20	NOT SHOWN (HONDA RECTIFIER)
151	9.802-775.0	2	NUT 1/4-20	NOT SHOWN (HONDA RECTIFIER)
152	9.802-778.0	3	NUT, 5/16" WHIZ LOC FLANGE	

8.928-276.0

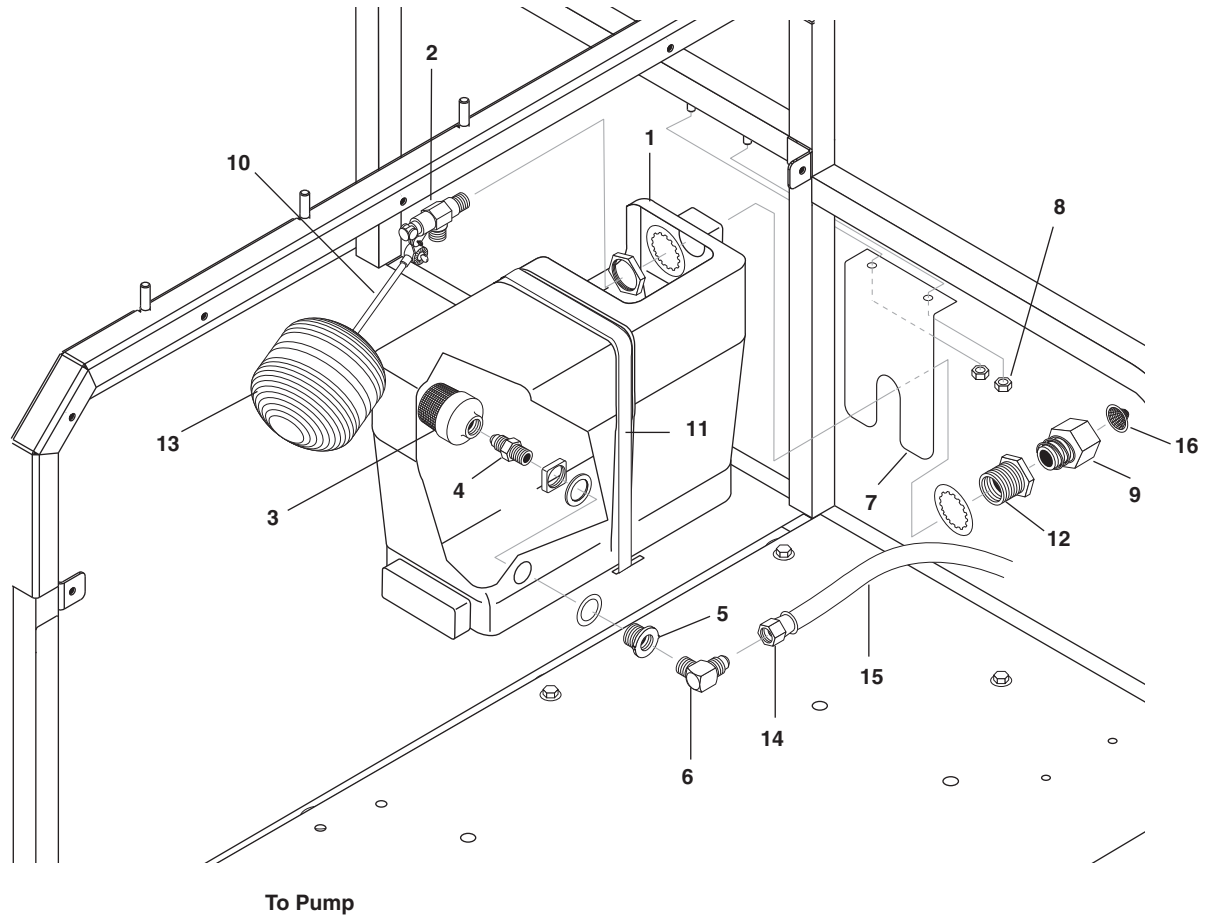

REF	PART NO.	QTY	DESCRIPTION	NOTES
1	9.804-042.0	1	TANK, FLOAT, 2-1/2 GALLON, BLANK	
2	8.749-328.0	1	VALVE, FLOAT PLASTIC	
3	9.802-162.0	1	STRAINER, 1/2" BASKET	
4	9.802-128.0	1	NIPPLE, 1/2" JIC X 1/2" MPT	
5	8.750-743.0	1	BULKHEAD, 1/2" POLYPRO	
6	8.757-202.0	1	ELBOW, 3/4" 45° SAE X 1/2" M-NPTF, BRASS	
7	8.928-239.0	1	BRACKET, FLOAT TANK SUPPORT	
8	9.802-775.0	2	NUT, 1/4" FLANGE, ZN	
9	8.757-203.0	1	SWIVEL, 1/2" M-NPTF x 3/4" GHF	
10	9.803-671.0	1	STEM, 5" FLOAT	
11	9.802-512.0	1	CABLE, TY, 48"	
12	8.707-000.0	1	CONNECTOR, 1/2" ANCHOR	
13	9.802-061.0	1	BALL, FLOAT, BLACK PLASTIC	
14	9.802-152.0	1	SWIVEL, 3/4" SAE FEM	
15	9.802-261.0	24"	HOSE, PUSH-ON, /FT	
16	9.804-016.0	1	FILTER SCREEN WASHER, GARDEN HOSE/ 30MESH	

Control Panel

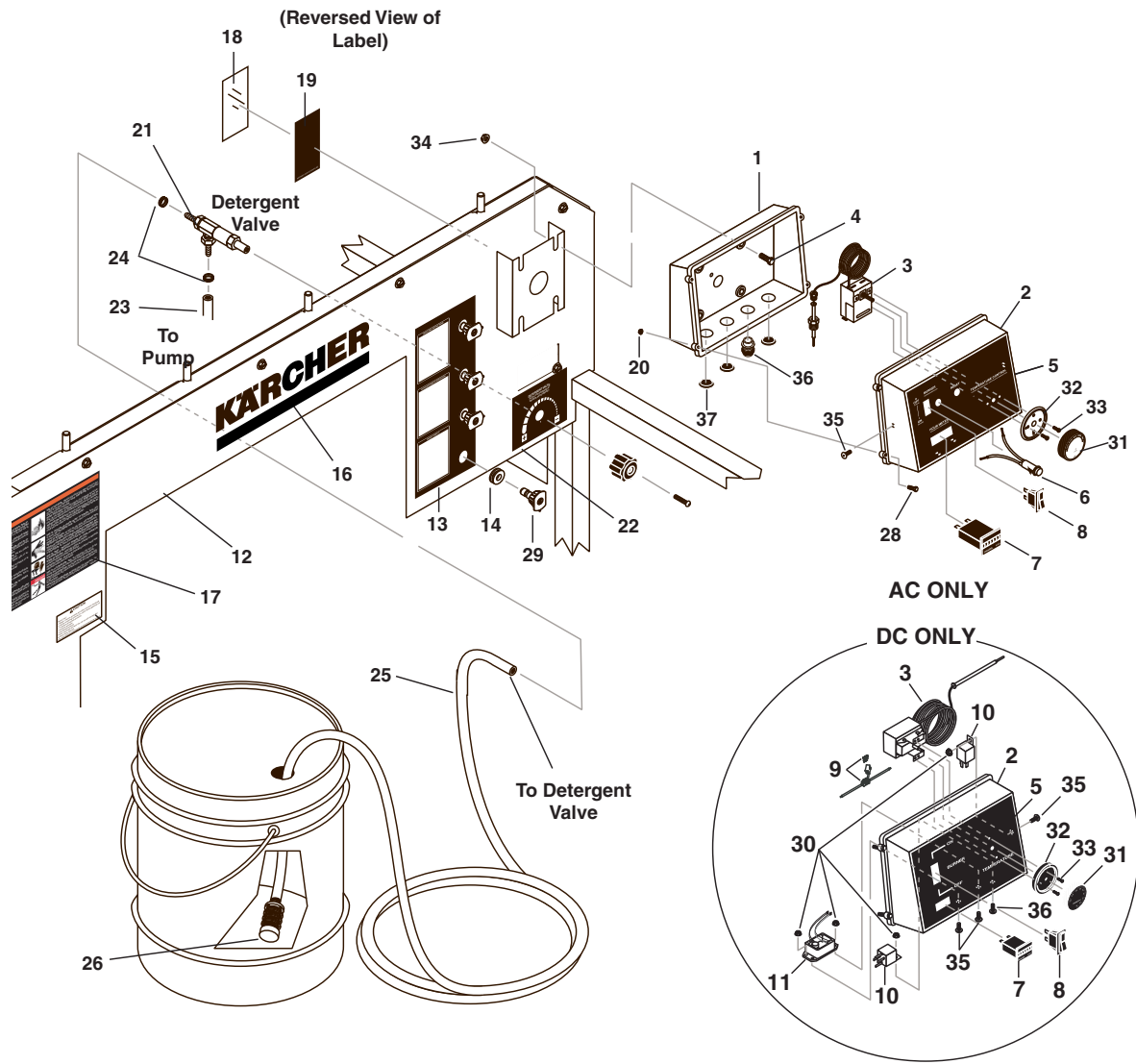

REF	PART NO.	QTY	DESCRIPTION	NOTES
1	9.803-693.0	1	BOX, PLASTIC, BACK	
2	9.802-482.0	1	BOX, PLASTIC, FRONT, FABRICATED	AC ONLY (581.0, 583.0, 585.0, 603.0)
-	8.719-947.0	1	BOX, PLASTIC, FRONT, 2 SQUARE HOLES	DC ONLY (579.0, 580.0, 582.0, 584.0)
3	8.750-094.0	1	THERMOSTAT, 302°F	
-	9.804-072.0	42"	WIRE, COVER	
4	9.802-700.0	4	BOLT, 1/4" X 3/4" HH NC	

REF	PART NO.	QTY	DESCRIPTION	NOTES
5	8.758-399.0	1	LABEL CONTROL BOX SUPER SKID	DC ONLY (579.0, 580.0, 582.0, 584.0)
-	8.758-561.0	1	LABEL ELECTRICAL BOX WITH OUT RESET SSG	(603.0 ONLY)
-	8.758-503.0	1	LABEL ELECTRICAL BOX WITHOUT RESET	AC ONLY (581.0, 583.0, 585.0) W/GENERATOR
6	9.802-456.0	1	12V INDICATOR LIGHT, GREEN	DC ONLY (579.0, 580.0, 582.0, 584.0)
-	9.802-455.0	1	120V INDICATOR LIGHT, GREEN	AC ONLY (581.0, 583.0, 585.0, 603.0)
7	9.802-283.0	1	HOUR METER	
8	9.802-453.0	1	SWITCH, CURVETTE	AC ONLY (581.0, 583.0, 585.0, 603.0)
-	8.716-036.0	1	SWITCH, ROCKER, 15A/12V, LT(875465)	DC ONLY (579.0, 580.0, 582.0, 584.0)
9	8.716-223.0	1	HOLDER, FUSE	DC ONLY (579.0, 580.0, 582.0, 584.0)
-	8.716-206.0	1	FUSE, ATC 30 AMP	DC ONLY (579.0, 580.0, 582.0, 584.0)
10	9.802-470.0	2	RELAY, 12 V DC, 40 AMP	DC ONLY (579.0, 580.0, 582.0, 584.0)
11	8.752-804.0	1	REGULATOR, 12VOLT DC	DC ONLY (579.0, 580.0, 582.0, 584.0)
12	8.928-241.0	1	ASSY, CONTROL PANEL	ALL EXCEPT 1.110-603.0
-	8.928-303.0	1	ASSY, CONTROL PANEL	1.110-603.0
-	9.802-762.0	1	SCREW, GROUND POST 10/32" X 1-1/4"	
-	8.706-735.0	1	BUSHING, 1" SNAP	
13	8.758-435.0	1	LABEL CONTROL PANEL SSG	ALL EXCEPT 1.110-603.0
-	8.758-564.0	1	LABEL CONTROL PANEL CLEAR SSG	1.110-603.0
14	9.802-064.0	4	GROMMET, RUBBER, NOZZLE HOLDER	
15	8.758-476.0	1	LABEL STEAM VALVE	
16	8.758-364.0	1	LABEL KARCHER STRIPE 17" X 3.875"	
17	8.758-412.0	1	LABEL WARNING SUPER SKID	
18	9.800-034.0	1	LEXAN, COVER, OUTDOOR	
19	8.758-336.0	1	LABEL ASSEMBLED IN USA OUTDOOR USE	
20	9.803-250.0	4	NUT	
21	9.802-188.0	1	VALVE, METERING	
22	8.758-471.0	1	LABEL DETERGENT VALVE	ALL EXCEPT 1.110-603.0
-	8.758-679.0	1	LABEL DETERGENT VALVE SSG/TNT	1.110-603.0
23	9.802-251.0	24"	TUBE 1/4" x 1/2", CLEAR VINYL /FT	
24	6.390-126.0	3	CLAMP, HOSE, .46-, .54 ST	
25	9.802-251.0	6 ft.	HOSE, 1/4" X 1/2" CLEAR VINYL	
26	8.707-058.0	1	STRAINER, 1/4" BRASS	
27	8.758-327.0	1	LABEL GROUND SYMBOL	
28	9.803-249.0	4	SCREW, M4 X 10	
29	-	-	PLEASE SEE HOSE & SPRAY GUN ASSEMBLY PAGE	
30	9.802-695.0	6	NUT 10/32" KEPS	
31	8.750-096.0	1	KNOB, THERMOSTAT, 302°F	
32	8.712-190.0	1	BEZEL, THERMOSTAT	
33	8.718-779.0	2	SCREW, 4MM X 6MM	
34	9.802-775.0	4	NUT, 1/4" FLANGE ZINC	
35	9.802-759.0	4	SCREW, 10/32" X 1/2" BH SOC, BLACK	
36	9.802-514.0	1	STRAIN RELIEF, LT, STR, 1/2 NPT,.23-.45D	
37	8.706-745.0	3	PLUG, PLASTIC 0.812	

Hose & Spray Gun

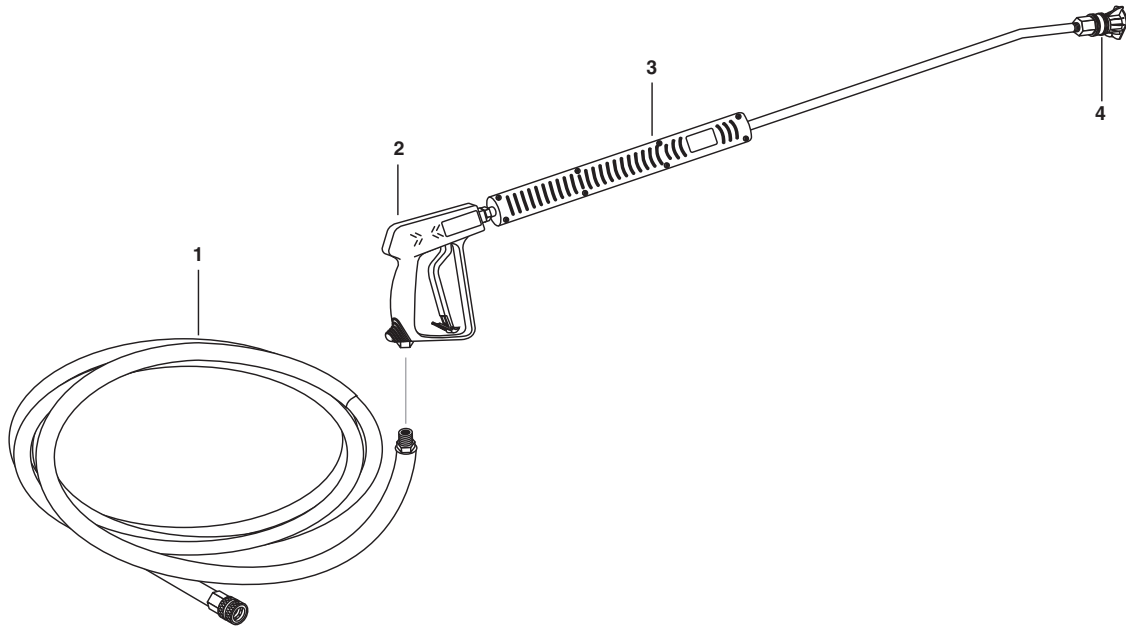

REF	PART NO.	QTY	DESCRIPTION	NOTES
1	8.739-203.0	1	HOSE, 3/8" X 50', 2 WIRE TUFF FLEX	
2	8.710-384.0	1	GUN, ST-1500, 5000 PSI 10.4 GPM	
3	9.803-805.0	1	WAND	
4	8.712-350.0	1	NOZZLE SAQCMEG 15045, YELLOW	1.110-579.0
-	8.712-351.0	1	NOZZLE, SAQCMEG 25045, GREEN	1.110-579.0
-	8.712-352.0	1	NOZZLE, SAQCMEG 4004.5, WHITE	1.110-579.0
-	9.802-304.0	1	NOZZLE, 1505.5, YELLOW	1.110-580.0, 1.110-581.0
-	9.802-305.0	1	NOZZLE, 2505.5, GREEN	1.110-580.0, 1.110-581.0
-	9.802-306.0	1	NOZZLE, 4005.5, WHITE	1.110-580.0, 1.110-581.0
-	8.712-354.0	1	NOZZLE, SAQCMEG 1505, YELLOW	1.110-582.0, 1.110-583.0, 1.110-603.0
-	8.712-355.0	1	NOZZLE, SAQCMEG 2505, GREEN	1.110-582.0, 1.110-583.0, 1.110-603.0
-	8.712-356.0	1	NOZZLE, SAQCMEG 4005, WHITE	1.110-582.0, 1.110-583.0, 1.110-603.0
-	8.712-362.0	1	NOZZLE, 1506, YELLOW	1.110-584.0, 1.110-585.0
-	8.712-363.0	1	NOZZLE, SAQCMEG 2506, GREEN	1.110-584.0, 1.110-585.0
-	8.712-364.0	1	NOZZLE, SAQCMEG 4006, WHITE	1.110-584.0, 1.110-585.0

Wayne Burner Specifications

Model No.	Burner Part No.	Fuel Nozzle w/ 100psi Check Valve
1.110-579.0	8.756-480.0	8.755-610.0
1.110-580.0	8.756-480.0	8.756-697.0
1.110-581.0*	8.756-413.0	8.756-697.0
1.110-582.0	8.756-480.0	8.756-697.0
1.110-583.0*	8.756-413.0	8.756-697.0
1.110-584.0	8.756-890.0	8.756-900.0
1.110-585.0*	8.756-413.0	8.756-900.0
1.110-603.0*	8.756-413.0	8.756-697.0

Models Equipped with Generator:

1.110-581.0, 1.110-583.0,
1.110-585.0, 1.110-603.0

Pump Specifications

Model No.	Pump Model	Part Number	Unloader	Pulley	Pulley Part #	Bushing	Bushing Part #
1.110-579.0	KT4540	8.921-714.0	8.715-483.0	2BK100H	9.802-391.0	H X 25MM	9.802-403.0
1.110-580.0	KT6036	8.921-716.0	8.715-483.0	2BK90H	8.715-593.0	H X 25MM	9.802-403.0
1.110-581.0*	KT6036	8.921-716.0	8.715-483.0	2BK90H	8.715-593.0	H X 25MM	9.802-403.0
1.110-582.0	KT6036	8.921-716.0	8.715-483.0	2BK100H	9.802-391.0	H X 25MM	9.802-403.0
1.110-583.0*	KT6036	8.921-716.0	8.715-483.0	2BK100H	9.802-391.0	H X 25MM	9.802-403.0
1.110-584.0	KT6036	8.921-716.0	8.715-483.0	2BK90H	8.715-593.0	H X 25MM	9.802-403.0
1.110-585.0*	KT6036	8.921-716.0	8.715-483.0	2BK90H	8.715-593.0	H X 25MM	9.802-403.0
1.110-603.0*	KT6036	8.921-716.0	8.715-483.0	2BK100H	9.802-391.0	H X 25MM	9.802-403.0

Generator Specifications

Model No.	Pulley	Pulley Part #	Belt	Belt Part #	Bushing	Bushing Part #
1.110-581.0*	BK34H	9.802-378.0	BX34	8.715-695.0	H x 7/8	8.715-633.0
1.110-583.0*	BK34H	9.802-378.0	BX34	8.715-695.0	H x 7/8	8.715-633.0
1.110-585.0*	BK36H	9.802-379.0	BX34	8.715-695.0	H x 7/8	8.715-633.0
1.110-603.0*	BK34H	9.802-378.0	BX34	8.715-695.0	H x 7/8	8.715-633.0

Engine Specifications

Model No.	Engine Model	Engine Part #	Engine Pulley	Pulley Part #	Bushing	Bushing Part #	Belt Size	Belt Part #
1.110-579.0	GX 390	9.802-321.0	2BK34H	9.802-382.0	H x 1	9.802-399.0	BX44(2)	8.715-705.0
1.110-580.0	Vanguard	8.754-819.0	2BK34H	9.802-382.0	H x 1	9.802-399.0	BX42(2)	8.715-703.0
1.110-581.0*	Vanguard	8.754-819.0	3TB34	9.802-392.0	P2 x 1	9.802-404.0	BX42(2)	8.715-703.0
1.110-582.0	GX 630	8.752-149.0	2BK36	9.802-383.0	H x 1	9.802-399.0	BX44(2)	8.715-705.0
1.110-583.0*	GX 630	8.752-149.0	3TB34H	9.802-392.0	P2 X 1	9.802-404.0	BX44(2)	8.715-705.0
1.110-584.0	GX 690	8.757-350.0	2BK40	9.802-384.0	H x 1-1/8"	9.802-400.0	BX43(2)	9.802-420.0
1.110-585.0*	GX 690	8.757-350.0	3TB36H	9.802-393.0	P2 X 1-1/8"	9.802-405.0	BX43(2)	9.802-420.0
1.110-603.0*	GX 630	8.752-149.0	3TB34H	9.802-392.0	P2 X 1	9.802-404.0	BX44(2)	8.715-705.0

GX390 = 389CC

GX630 = 688CC

GX660 = 688CC

Vanguard = 570CC

Pump - 5-2300, 5-3000, 6-3200 KT.2 Series

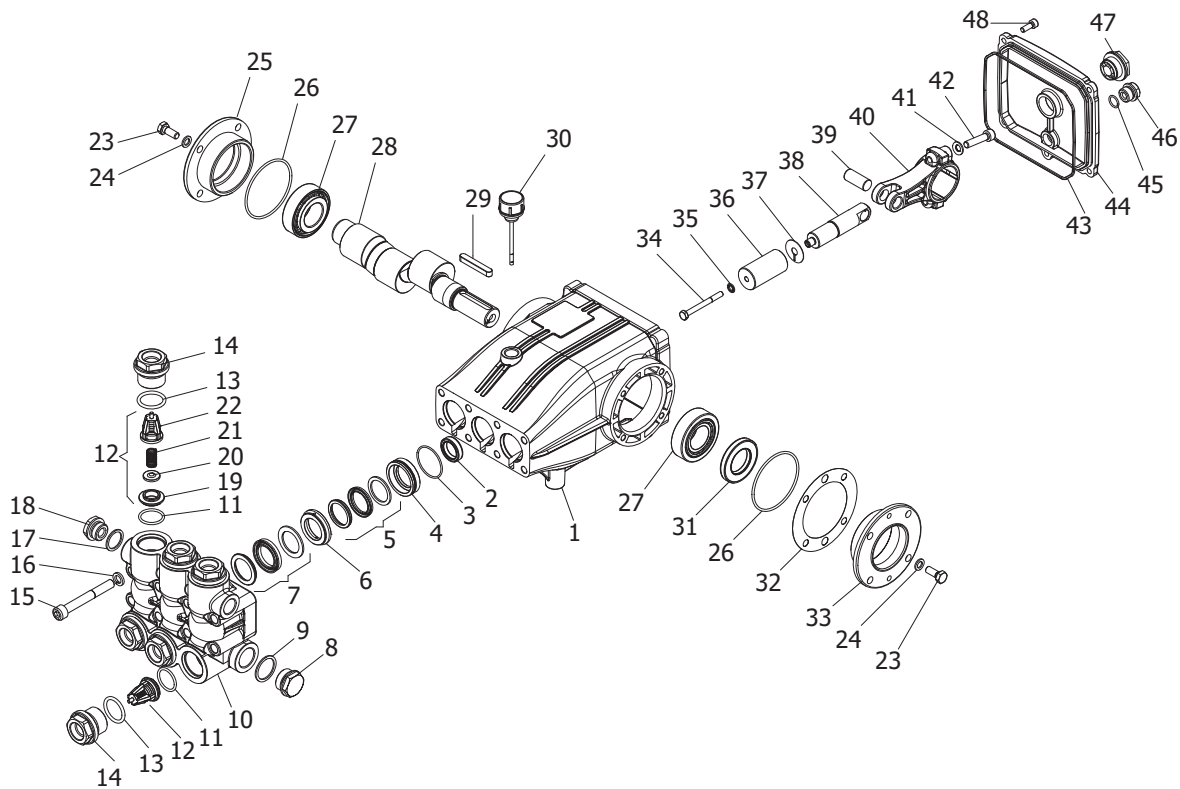

REF	PART NO.	QTY	DESCRIPTION	NOTES
1	8.752-825.0	1	CRANKCASE	
2	-	3	PLUNGER OIL SEAL	SEE KITS TABLE
3	-	3	O-RING Ø1.78 X 37.82	SEE KITS TABLE
4	-	3	PRESSURE RING, 18MM	SEE KITS TABLE
5	-	3	U-SEAL, 18MM	SEE KITS TABLE
6	-	3	INTERMEDIATE RING, 18MM	SEE KITS TABLE
7	-	3	U-SEAL, 18MM	SEE KITS TABLE
8	9.802-926.0	1	BRASS PLUG, G1/2	
9	9.803-199.0	1	COPPER WASHER 1/2	
10	8.753-816.0	1	MANIFOLD HOUSING	
11	9.804-498.0	6	O-RING Ø2.62 X 25.1	SEE KITS TABLE
12	-	6	VALVE ASSEMBLY	SEE KITS TABLE
13	9.803-193.0	6	O-RING 3068	SEE KITS TABLE
14	9.802-928.0	6	VALVE PLUG	
15	8.753-817.0	8	MANIFOLD STUD BOLT	
16	9.802-890.0	8	LOCK WASHER	
17	8.719-008.0	1	COPPER WASHER 3/8	
18	8.707-262.0	1	BRASS PLUG 3/8	
19	-	6	VALVE SEAT	SEE KITS TABLE
20	-	6	VALVE PLATE	SEE KITS TABLE

Pump - 5-2300, 5-3000, 6-3200 KT.2 Series

REF	PART NO.	QTY	DESCRIPTION	NOTES
21	-	6	VALVE SPRING	SEE KITS TABLE
22	-	6	VALVE CAGE	SEE KITS TABLE
23	8.752-830.0	8	HEX SCREW	
24	9.802-884.0	8	WASHER	
25	9.803-182.0	1	CLOSED BEARING HOUSING	
26	9.803-186.0	2	O-RING Ø2.62 X 71.12	
27	9.803-160.0	2	ROLLER BEARING	
28	8.753-818.0	1	CRANKSHAFT Ø25 (4540)	
-	8.752-827.0	1	CRANKSHAFT Ø25 (6036)	
29	9.803-167.0	1	CRANKSHAFT KEY	
30	8.752-834.0	1	OIL DIP STICK	
31	9.803-139.0	1	CRANKSHAFT SEAL	
32	9.803-177.0	2	SHIM	
33	9.803-181.0	1	BEARING HOUSING	
34	8.752-841.0	3	PLUNGER BOLT	SEE KITS TABLE
35	8.752-820.0	3	BONDED SEAL	SEE KITS TABLE
36	8.753-819.0	3	PLUNGER, 18MM	SEE KITS TABLE
37	8.752-823.0	3	COPPER SPACER	SEE KITS TABLE
38	8.753-820.0	3	PLUNGER ROD	
39	8.752-822.0	3	CONNECTING ROD PIN	
40	8.752-821.0	3	CONNECTING ROD	
41	9.802-889.0	6	SPRING WASHER	
42	9.802-937.0	6	CONNECTING ROD SCREW	
43	9.803-194.0	1	O-RING Ø2.62 X 152.07	
44	8.752-826.0	1	CRANKCASE COVER	
45	9.803-906.0	1	O-RING Ø1.78 X 14.00	
46	8.707-262.0	1	BRASS PLUG G3/8	
47	9.803-202.0	1	SIGHT GLASS G3/4	
48	8.752-824.0	5	COVER SCREW	

KIT NUMBERS	8.753-821.0	8.758-061.0	8.753-823.0	8.753-824.0	8.752-835.0
KIT DESCRIPTION	Plunger Seals 18 mm	Seal Packing 18 mm	Plunger 18 mm	Complete Valve	Plunger Oil Seals
ITEM NUMBERS INCLUDED	3, 5, 7	3, 4, 5, 6, 7	34, 35, 36, 37	11, 12, 13	2
NUMBER OF CYLINDERS KIT WILL SERVICE	3	3	1	6	3

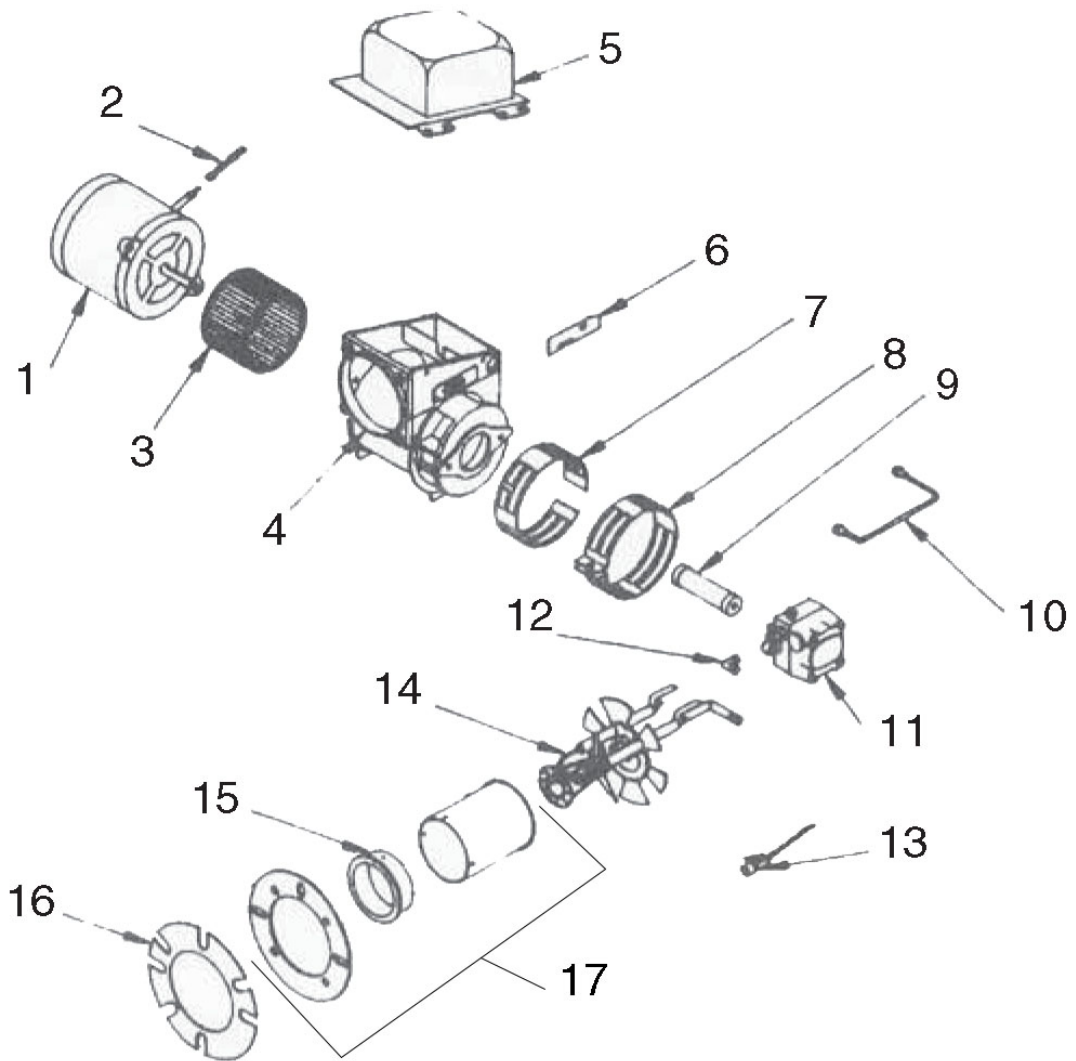

REF	PART NO.	QTY	DESCRIPTION	NOTES
1	8.756-716.0	1	MOTOR, 1/4 13.5VDC AMETEK	
2	13121	1	MOTOR CORD COVER	
3	8.756-726.0	1	FAN, 3.44"W X 5.25"D 5/16" BORE	
4	8.700-735.0	1	BURNER HOUSING-PAINTED	
5	9.107-507.0	1	IGNITOR, 12VDC, LOW AMP	
6	13392	1	SLOT COVER PLATE	
7	8.700-732.0	1	AIR BAND - INNER 8 SLOT	
8	8.700-729.0	1	AIR BAND - OUTER 8 SLOT	
9	8.756-715.0	1	COUPLING - 'E' DC	
10	8.700-704.0	1	OIL LINE ASSEMBLY	
11	8.756-437.0	1	PUMP, COMBO 12V/24V	
12	13494	1	BRASS 90° ELBOW	
13	8.700-819.0	1	CAD CELL	
-	8.756-661.0	1	TIMER, DROP OUT	
14	8.756-299.0	1	GUN ASSEMBLY, BURNER-RG/*CST/GBB	LESS THAN 5 GPM UNITS
-	8.756-879.0	1	GUN-RG/SST/2"BB2	5+ GPM UNITS
15	8.700-724.0	1	AIR CONE #4A	
16	8.700-692.0	2	GASKET E & M SERIES BURNERS	
17	8.756-305.0	1	FLANGE, AIR TUBE, WELDED 1.75" "E"	
18	2794-011	1	PEDESTAL	NOT SHOWN
19	8.700-770.0	1	KIT, ELECTRODE REPLACEMENT (PAIR)	
20	8.757-835.0	1	KIT, IGNITOR/TIMER/CAD CELL W PLATE REPLACEMENT	(ITEMS 5, 13, & MOUNT PLATE)

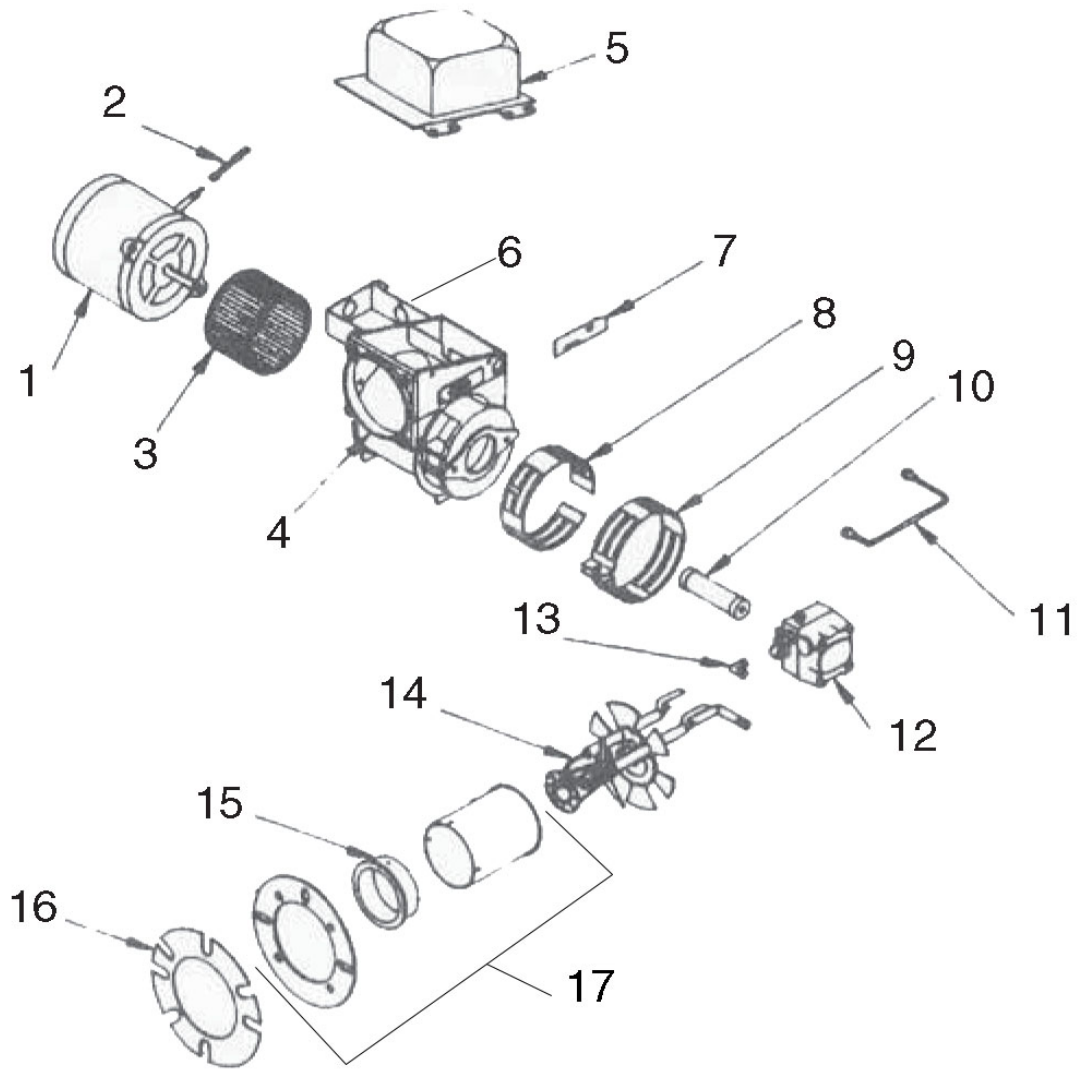

REF	PART NO.	QTY	DESCRIPTION	NOTES
1	8.756-436.0	1	MOTOR, 1/4 120V 50-60HZ	
2	13121	1	MOTOR CORD COVER	
3	8.756-438.0	1	FAN - 4.00"W X 6.25"D 1/2" BORE	
4	8.700-735.0	1	BURNER HOUSING EHASR	
5	8.700-802.0	1	IGNITOR, 120V, SIDE EH-EHA MOUNT	
6	13392	1	SLOT COVER PLATE	
7	8.700-732.0	1	BAND, AIR BURNER INNER EHA/SR	
8	8.700-729.0	1	AIR BAND 8 HOLE OUTER EHA/SR	
9	8.700-776.0	1	COUPLING 5/16 x 1/2'FS	
10	8.700-704.0	1	OIL LINE, 6'	
11	8.756-290.0	1	FUEL PUMP, WCS - COMBO/W SOLENOID 120V	
12	13494	1	BRASS 90° ELBOW	
13	8.756-704.0	1	ASSY, BURNER GUN, RG/SST/2"BB	
14	8.700-724.0	1	CONE 4A FOR 307000,003,007	
15	8.700-692.0	1	GASKET, E & M SERIES BURNERS	(2 EACH)
16	8.756-305.0	1	FLANGE, AIR TUBE, WELDED 1.75" "E"	
17	8.700-770.0	1	KIT, ELECTRODE REPLACEMENT (PAIR)	

VRT 3 Unloader

8.750-297.0, 8 GPM, 2320 PSI

8.750-298.0, 8 GPM, 3630 PSI

8.750-299.0, 8 GPM, 4500 PSI

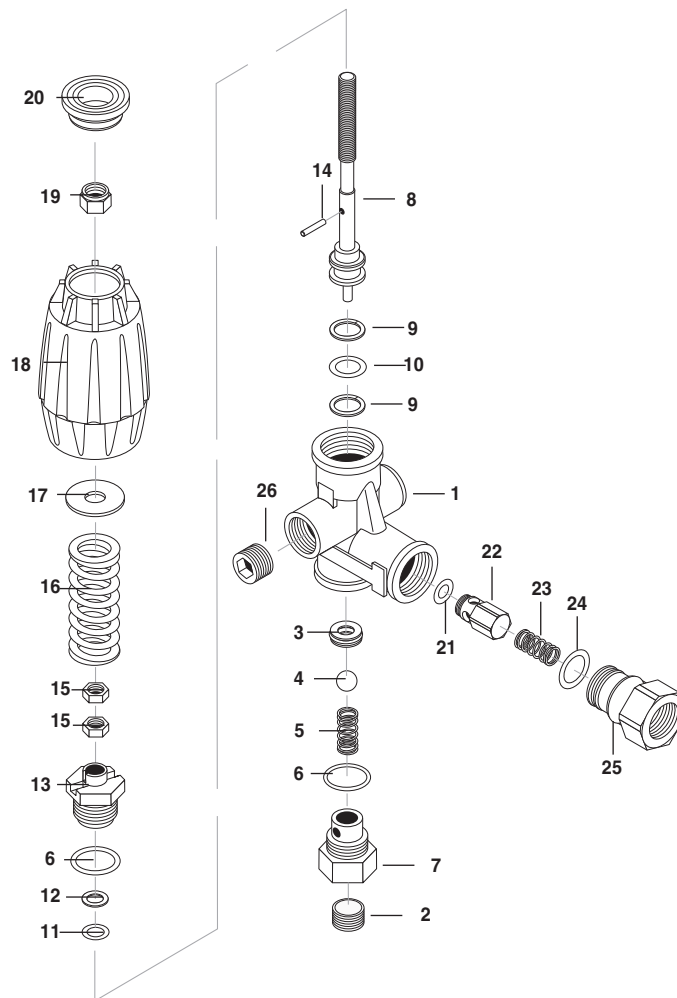

REF	PART NO.	QTY	DESCRIPTION	NOTES
18	8.750-712.0	1	KNOB, UNLOADER	
25	8.750-713.0	1	OUTLET FITTING	
-	8.750-709.0	1	REPAIR KIT, VRT3, 2320/3630 PSI	
-	8.750-710.0	-	REPAIR KIT VRT3 4500 PSI	KIT ITEMS: 3, 4, 6, 9-12, 21, 24

Unloader Adjustment Procedures

1. Remove lock nut (Item 19).
2. Remove adjustment knob (Item 18).
3. Loosen the two (2) nuts (Item 15), move them upward on stem (Item 8) until you see 4 or more threads below the nut.
4. Re-attach adjusting knob (Item 18).
5. Start machine. Open the trigger of the spray gun. Increase pressure by turning adjustment knob (Item 18) clockwise until pressure is at the desired operating pressure.
6. Remove the adjustment knob (Item 18), tighten the lower nut (Item 15) tightly against the upper nut (Item 15). Re-attach adjustment knob (Item 18) and screw down until contact is made with the nuts (Items 15). Screw down lock nut (Item 19) onto the stem (Item 8) until the threads cut into the nylon insert of the lock nut (Item 19).

*If adjustment knob (Item 18) DOES NOT make contact with upper nut (Items 15), remove adjusting knob (Item 18), re-adjust (raise) nuts (Items 15) on stem (Item 8) and re-attach adjustment knob (Item 18), then repeat step #6.

**If adjustment knob (Item 18) DOES make contact with upper nut; release the trigger of the spray gun and watch the pressure gauge for the pressure increase ("spike"). This "spike" SHOULD NOT exceed 500 psi above the operating pressure. If "spike" pressure exceeds the 500 psi limit, remove the adjusting knob (Item 18) and re-adjust (lower) the nuts (Items 15) on the stem (Item 8). Re-attach the adjusting knob (Item 18), then repeat step #6.



THANK YOU!

MERCI! ¡GRACIAS! DANKE!



Register your product and benefit from many advantages.

Enregistrez votre produit et bénéficiez de nombreux avantages.

Registre su producto y aproveche de muchas ventajas.

Registrieren Sie Ihr Produkt und Sie von vielen Vorteilen.

www.kaercher.com/welcome



Rate your product and tell us your opinion.

Évaluez votre produit et donnez-nous votre opinion.

Reseña su producto y díganos su opinión.

Bewerten Sie Ihr Produkt und sagen Sie uns Ihre Meinung.



www.kaercher.com/dealersearch

Kärcher North America
6398 N Kärcher Way
Aurora, CO 80019
Phone: +1 800 444-7654

