

PGDC

Hot Water - Gasoline Powered - Diesel/Oil Heated

LANDA®

Operator's Manual

Pressure Washer



MODELS:

**PGDC4 - 3500
1.110-049.0**

**PGDC5 - 3500
1.110-050.0**

**PGDC5 - 3500
1.110-051.0**

**PGDC8 - 3000
1.110-072.0**

**PGDC5 - 3500
1.110-096.0**

**PGDC8 - 3000
1.110-098.0**

For the Landa Dealer nearest you, consult our web page at www.landa.com

SHOP PRESSURE WASHER PARTS

shoppressurewasherparts.com | (888) 269-0172



8.916-596.0 - BU 02/01/23

Machine Data Label

Model: _____

Date of Purchase: _____

Serial Number: _____

Dealer: _____

Address: _____

Phone Number: _____

Sales Representative: _____

Machine Data Label2
Table of Contents3
How To Use This Manual4

Safety

Introduction & Safety Information5
Important Safety Information.5

Operations

Component Identification9
Assembly Instructions10
Battery Installation10
Operation Instructions11
Detergents & General Cleaning Techniques12
Shutting Down And
Clean-up13

Maintenance

Storage14
Engine Maintenance14
Burner Air Adjustment17
Troubleshooting18
Preventative Maintenance22
Maintenance Schedule22
Oil Change Record23

Parts

Landa PGDC. 26
Power Platform 30
Control Box 33
Coil 34
Option, Float Tank 36
Hose & Spray Gun 38
Burner 39
Unloader - 4-3500, 5-3500 40
Unloader - 8-3000 41
Pump. 42
Specifications 44
PGDC Series Wayne “EHASR-DC” Burner 45
LT.2 Series Pump 46
VRT3 Unloader 48

How To Use This Manual

This manual contains the following sections:

- How to Use This Manual
- Safety
- Operations
- Maintenance
- Parts List

The HOW TO USE THIS MANUAL section will tell you how to find important information for ordering correct repair parts.

Parts may be ordered from authorized dealers. When placing an order for parts, the machine model and machine serial number are important. Refer to the MACHINE DATA box which is filled out during the installation of your machine. The MACHINE DATA box is located on the inside of the front cover of this manual.

Model: _____
Date of Purchase: _____
Serial Number: _____
Dealer: _____
Address: _____
Phone Number: _____
Sales Representative: _____

The model and serial number of your machine is located on the back of the machine.

The SAFETY section contains important information regarding hazardous or unsafe practices of the machine. Levels of hazards are identified that could result in product damage, personal injury, or severe injury resulting in death.

The OPERATIONS section is to familiarize the operator with the operation and function of the machine.

The MAINTENANCE section contains preventive maintenance to keep the machine and its components in good working condition. They are listed in this general order:

- Storage
- Engine Maintenance
- Landa Sure Fire Oil Burner
- Troubleshooting
- Preventative Maintenance
- Oil Change Record

The PARTS LIST section contains assembled parts illustrations and corresponding parts list. The parts lists include a number of columns of information:

- **REF** – column refers to the reference number on the parts illustration.
- **PART NO.** – column lists the part number for the part.
- **QTY** – column lists the quantity of the part used in that area of the machine.
- **DESCRIPTION** – column is a brief description of the part.
- **NOTES** – column for information not noted by the other columns.

NOTE: If a service or option kit is installed on your machine, be sure to keep the KIT INSTRUCTIONS which came with the kit. It contains replacement parts numbers needed for ordering future parts.

NOTE: The manual part number is located on the lower right corner of the front cover.

Introduction & Safety Information

Thank you for purchasing this Pressure Washer. We reserve the right to make changes at any time without incurring any obligation.

Owner/User Responsibility:

The owner and/or user must have an understanding of the manufacturer's operating instructions and warnings before using this pressure washer. Warning information should be emphasized and understood. If the operator is not fluent in English, the manufacturer's instructions and warnings shall be read to and discussed with the operator in the operator's native language by the purchaser/owner, making sure that the operator comprehends its contents.

Owner and/or user must study and maintain for future reference the manufacturers' instructions.

The operator must know how to stop the machine quickly and understand the operation of all controls. Never permit anyone to operate the engine without proper instructions.

SAVE THESE INSTRUCTIONS

This manual should be considered a permanent part of the machine and should remain with it if machine is resold.

When ordering parts, please specify model and serial number. Use only identical replacement parts.

This machine is to be used only by trained operators.

Important Safety Information

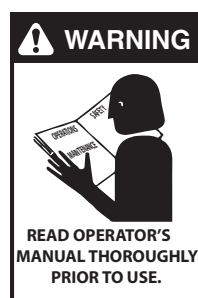

WARNING: To reduce the risk of injury, read operating instructions carefully before using.

AVERTISSEMENT: Pour réduire le risque de blessures, lire attentivement les instructions de fonctionnement avant l'utilisation

1. Read the owner's manual thoroughly. Failure to follow instructions could cause malfunction of the machine and result in death, serious bodily injury and/or property damage.
2. Know how to stop the machine and bleed pressure quickly. Be thoroughly familiar with the controls.
3. Stay alert — watch what you are doing.



DANGER: Keep wand, hose, and water spray away from electric wiring or fatal electric shock may result.

DANGER: Garder la lance, le boyau et le jet d'eau à l'écart de tout câblage électrique ou des chocs électriques mortels pourraient survenir.

4. All installations must comply with local codes. Contact your electrician, plumber, utility company or the selling distributor for specific details.



WARNING: This machine exceeds 85 db appropriate ear protection must be worn.

AVERTISSEMENT: Cette machine excède XX dB et une protection de l'ouïe appropriée doit être portée



WARNING: High pressure spray can cause paint chips or other particles to become airborne and fly at high speeds. To avoid personal injury, eye, hand and foot safety devices must be worn.

AVERTISSEMENT: Un jet haute pression peut écailler la peinture ou provoquer l'émission d'autres

particules dans l'air et leur projection à hautes vitesses. Pour éviter les lésions corporelles, une protection des yeux, du visage, des mains et des pieds doit être portée lors de l'utilisation de cet équipement

1. Always wear properly rated eye protection such as safety goggles or face shield while spraying.
(Safety glasses do not provide full protection.)

2. Keep operating area clear of all persons.

WARNING: Flammable liquids can create fumes which can ignite, causing property damage or severe injury.

AVERTISSEMENT: Des liquides inflammables peuvent produire des vapeurs qui peuvent s'enflammer, causant ainsi des dommages à la propriété ou des blessures graves.



WARNING: Risk of explosion — Operate only where open flame or torch is permitted.

AVERTISSEMENT: Risque d'explosion - Utiliser uniquement dans des endroits où l'utilisation d'une flamme nue ou d'une torche est permise.



WARNING: Risk of fire — Do not add fuel when the machine is operating or still hot.

AVERTISSEMENT: Risque d'incendie-Ne pas ajouter de carburant pendant que la machine fonctionne ou est encore chaude.

WARNING: Do not use gasoline crankcase drainings or oil containing gasoline, solvents or alcohol. Doing so will result in fire and/or explosion.

AVERTISSEMENT: Ne pas utiliser d'essence, de drainage du carter de moteur ou d'essence contenant de l'huile, de solvants ou de l'alcool.



WARNING: Risk of fire — Do not Spray flammable liquids.

AVERTISSEMENT: Risque d'incendie- Ne pas pulvériser de liquides inflammables

3. Allow engine to cool for 1-2 minutes before refueling. If any fuel is spilled, make sure the area is dry before testing the spark plug or starting the engine. (Fire and/or explosion may occur if this is not done.)

Gasoline engines on mobile or portable equipment shall be refueled:

- a. outdoors;
- b. with the engine on the equipment stopped;
- c. with no source of ignition within 10 feet of the dispensing point; and
- d. with an allowance made for expansion of the fuel should the equipment be exposed to a higher ambient temperature.

In an overfilling situation, additional precautions are necessary to ensure that the situation is handled in a safe manner.

WARNING: Risk of injury. Disconnect battery ground terminal before servicing.

AVERTISSEMENT: Risque de blessures. Débrancher la borne de mise à la terre de la batterie avant de procéder à des opérations d'entretien

4. When in use, do not place machine near flammable objects as the engine is hot.
5. Oil burning appliances shall be installed only in locations where combustible dusts and flammable

gases or vapors are not present. Do not store or use gasoline near this machine.

- Use No. 1 or No. 2 heating oil (ASTM D306) only. **NEVER** use gasoline in your fuel oil tank. Gasoline is more combustible than fuel oil and could result in a serious explosion. **NEVER** use crankcase or waste oil in your burner. Fuel unit malfunction could result from contamination.
- Do not confuse gasoline and fuel oil tanks. Keep proper fuel in proper tank.



WARNING: Risk of injury. Hot surfaces can cause burns. Use only designated gripping areas of spray gun and wand. Do not place hands or feet on non-insulated areas of the pressure washer.

AVERTISSEMENT: Risque de blessures. Les surfaces chaudes peuvent causer des brûlures.

Utiliser uniquement les zones de prise désignées du pistolet pulvérisateur et de la lance. Ne pas placer les mains ou les pieds sur des endroits non isolés de la laveuse à pression

- Transport/Repair with fuel tank EMPTY or with fuel shut-off valve OFF.



CAUTION: Hot discharge fluid. Do not touch or direct discharge stream at persons or animals.

ATTENTION: Liquide de décharge chaud. Ne pas toucher ou décharger directement le jet vers des personnes ou des animaux

WARNING: This machine produces hot water and must have insulated components attached to protect the operator.

AVERTISSEMENT: Cette machine produit de l'eau chaude et doit comporter des composants isolés attachés pour protéger l'opérateur

- To reduce the risk of injury, close supervision is necessary when a machine is used near children. Do not allow children to operate the pressure washer. **This machine must be attended during operation.**



WARNING: Grip cleaning wand securely with both hands before starting. Failure to do this could result in injury from a whipping wand.

AVERTISSEMENT: Agripper la lance de nettoyage avec les deux mains avant de commencer. Le non-respect de cette consigne pourrait mener à des blessures

causées par le mouvement violent de la lance

- Never make adjustments on machine while in operation. Be certain all quick coupler fittings are secured before using pressure washer.



WARNING: High pressure developed by these machines will cause personal injury or equipment damage. Keep clear of nozzle. Use caution when operating. Do not direct discharge stream at people and animals, or severe injury or death will result.

AVERTISSEMENT: La haute pression générée par ces machines causera des lésions corporelles ou des dommages à l'équipement.

Se tenir à l'écart de la buse. Faire preuve de prudence lors de l'utilisation. Ne pas décharger directement le jet vers des personnes ou des animaux, car cela risquerait de causer des blessures graves ou même la mort.



WARNING: Protect machine from freezing.

AVERTISSEMENT: Protéger la machine contre le gel.

- To keep machine in best operating conditions, it is important you protect machine from freezing. Failure to protect machine from freezing could cause malfunction of the machine and result in death, serious bodily injury, and/or property damage. Follow storage instructions specified in this manual.
- Inlet water must be clean fresh water and no hotter than 90°F.

Safety



DANGER: Risk of asphyxiation. Running this product indoors can result in death due to carbon monoxide, poison gas you cannot see or smell. Only use outdoors and far away from windows, doors, and openings or vents. Use this product only in a well ventilated area.

DANGER: Risque d'asphyxie.

L'utilisation de ce produit à l'intérieur peut causer la mort par monoxyde de carbone, un gaz toxique incolore et inodore. Utiliser uniquement à l'extérieur et à l'écart des fenêtres, des portes et des ouvertures ou fentes de ventilation. Utiliser ce produit uniquement dans un endroit bien ventilé.

13. Avoid installing machines in small areas or near exhaust fans. Adequate oxygen is needed for combustion or dangerous carbon monoxide will result.
14. Manufacturer will not be liable for any changes made to our standard machines or any components not purchased from us.
15. The best insurance against an accident is precaution and knowledge of the machine.



WARNING: Be extremely careful when using a ladder, scaffolding or any other relatively unstable location. The cleaning area should have adequate slopes and drainage to reduce the possibility of a fall due to slippery surfaces.

AVERTISSEMENT: Faire preuve d'une extrême prudence au moment d'utiliser une échelle, des échafaudages ou toute autre surface relativement instable. La zone de nettoyage doit avoir une pente et un drainage adéquats pour réduire la possibilité d'une chute due à une surface glissante

AVERTISSEMENT: Faire preuve d'une extrême prudence au moment d'utiliser une échelle, des échafaudages ou toute autre surface relativement instable. La zone de nettoyage doit avoir une pente et un drainage adéquats pour réduire la possibilité d'une chute due à une surface glissante

16. Do not allow acids, caustic or abrasive fluids to pass through the pump.
17. Never run pump dry or leave spray gun closed longer than 1-2 minutes.
18. Machines with shut-off spray gun should not be operated with the spray gun in the off position for extensive periods of time as this may cause damage to the pump.

19. Protect discharge hose from vehicle traffic and sharp objects. Inspect condition of high pressure hose before using or bodily injury may result.
20. Before disconnecting discharge hose from water outlet, turn burner off and open spray gun to allow water to cool below 100° before stopping the machine. Then open the spray gun to relieve pressure. Failure to properly cool down or maintain the heating coil may result in a steam explosion.
21. Do not overreach or stand on unstable support. Keep good footing and balance at all times.
22. Do not operate this machine when fatigued or under the influence of alcohol, prescription medications, or drugs.
23. In oil burning models, use only kerosene, No. 1 home heating fuel, or diesel. If diesel is used, add a soot remover to every tankful.



WARNING: Do not spray machine or any people, animals or electrical parts.

AVERTISSEMENT: Ne pas vaporiser sur la machine ou les gens, les animaux ou les pièces électriques



WARNING: If connection is made to a potable water system, the system shall be protected against back flow.

AVERTISSEMENT: Si une connexion est établie avec un approvisionnement en eau potable, un dispositif de protection contre le retour d'eau doit être fourni.

être fourni.



Follow the maintenance instructions specified in the manual.

Component Identification

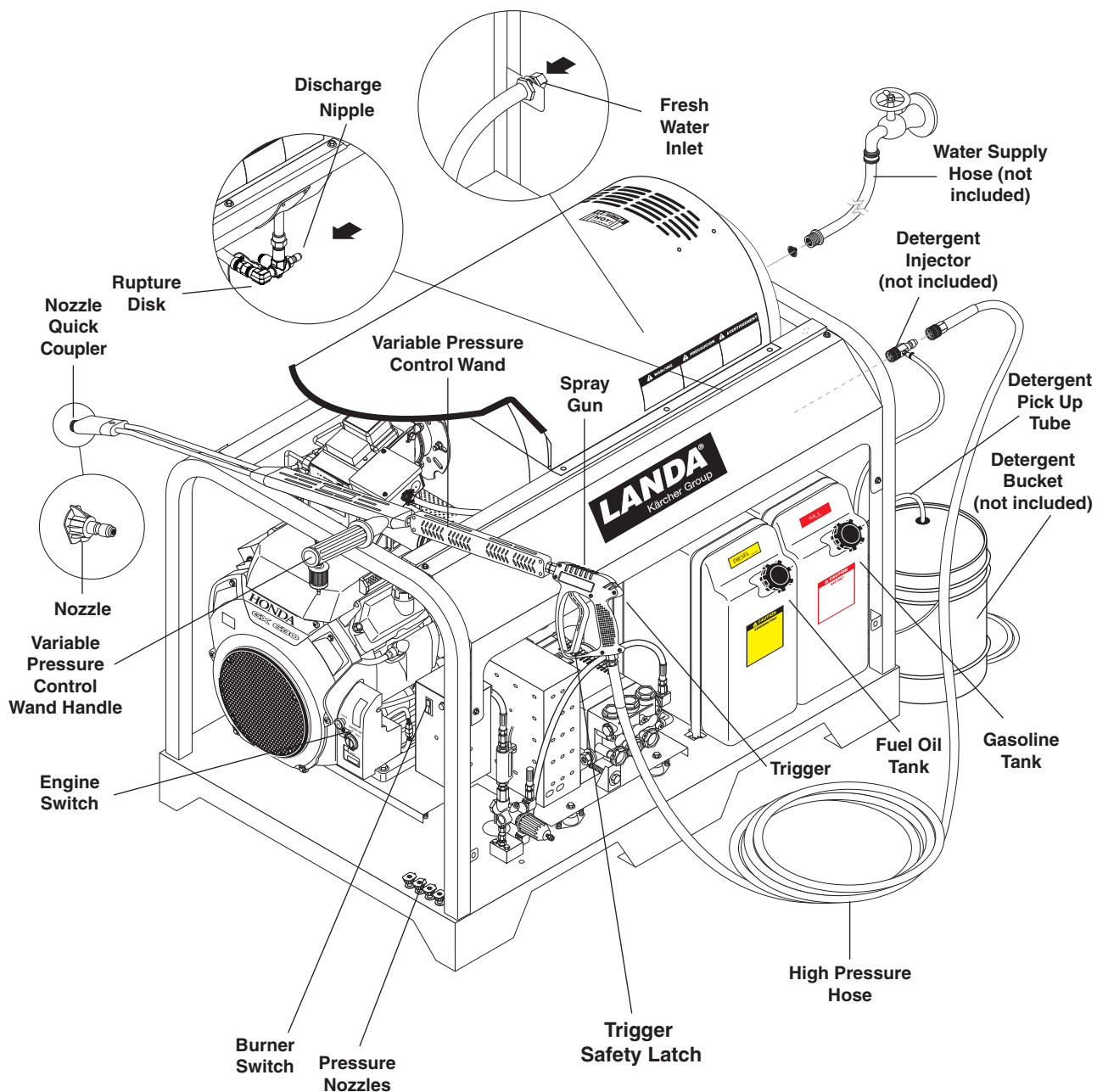

Operations

Assembly Instructions

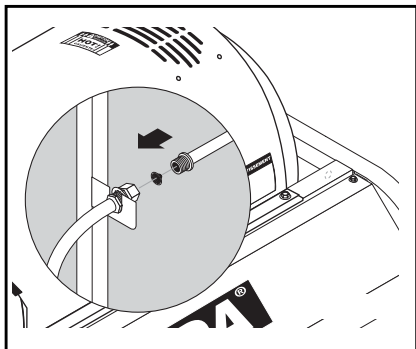

STEP 1: Attach a 5/8" water supply hose to inlet connector. Minimum flow should be 6 or 10 gpm depending on model of machine.

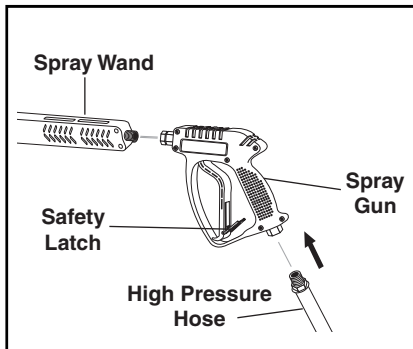

STEP 2: Attach wand to spray gun using teflon tape on threads to prevent leakage. Attach swivel connector on discharge hose to spray gun using teflon tape on threads. Attach swivel connector on high pressure hose to spray gun using teflon tape on threads. Engage safety latch to prevent from triggering gun when inserting high pressure nozzle.

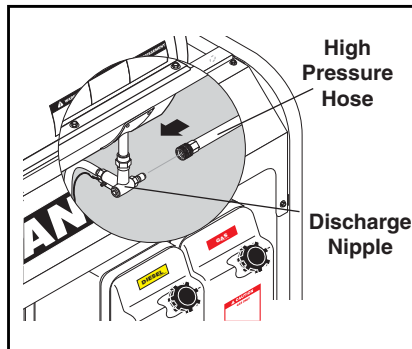

STEP 3: Attach high pressure hose to discharge nipple using quick coupler. Lock coupler securely into place by pulling back coupler collar and inserting it into discharge nipple, then pushing collar forward to lock in place.

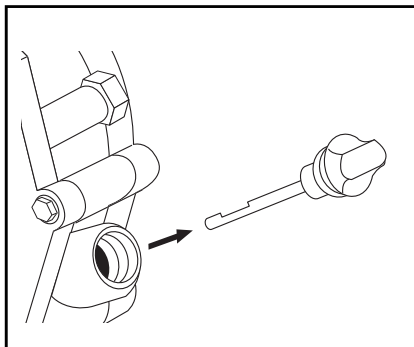

STEP 4: Check engine and pump oil level by removing oil dipstick, making sure oil is on proper indicator marking. Oil should be visible one half way up sight glass located at the end of pump (SAE 10W-40 non-foaming).

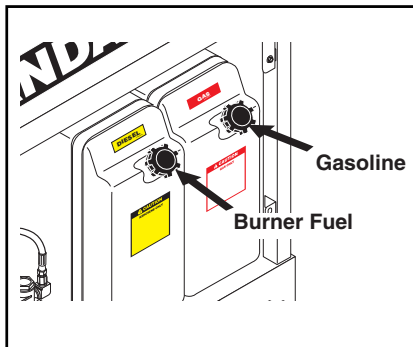

STEP 5: Fill red gasoline tank. Fill green fuel oil tank. Do not confuse gasoline and fuel oil (diesel) tanks. Keep proper fuel in proper tank.

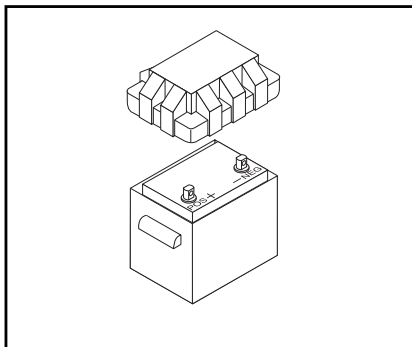

STEP 6: Install proper battery making sure that the red cable is attached to the positive terminal. Use a 12V Group 24 battery on all models except 4-40321 and 5-35321E. These models use a U1 30 amp garden tractor style battery.

Battery Installation

Due to Federal Regulations concerning shipment of corrosive chemicals, batteries are not shipped with this machine.



Red Cable is attached to battery (+) positive terminal, black cable is connected to battery (-) negative terminal.

Local purchase of battery will be the responsibility of the owner. Automotive type 12 Volt Group 24 battery is recommended for placement within the weather resistant box. Follow safety and installation instructions furnished with the battery.

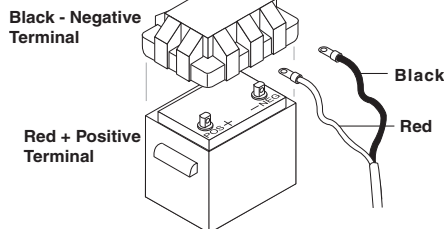

Operation Instructions

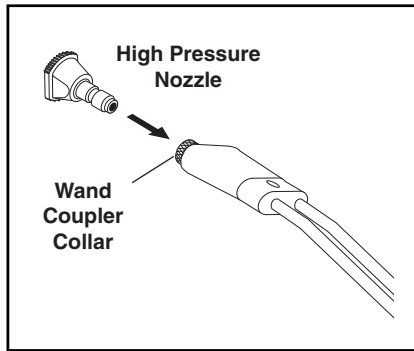

STEP 1: Read operator's manual before operating. Pull wand coupler collar back, insert desired pressure nozzle into coupler, then secure by pushing collar forward.

CAUTION: Never replace nozzles without engaging the safety latch on the spray gun trigger.

ATTENTION: Ne jamais remplacer les buses sans d'abord mettre le dispositif de sécurité sur la détente du pistolet pulvérisateur.

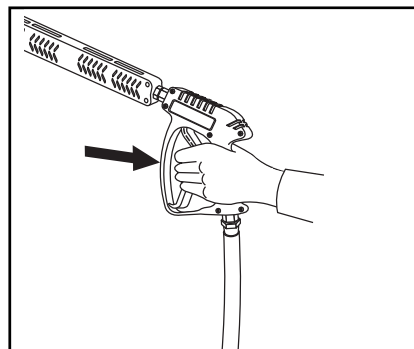

STEP 4: With the spray nozzle pointed away from you or anybody else, press the trigger on the spray gun to obtain pressurized cold water spray.

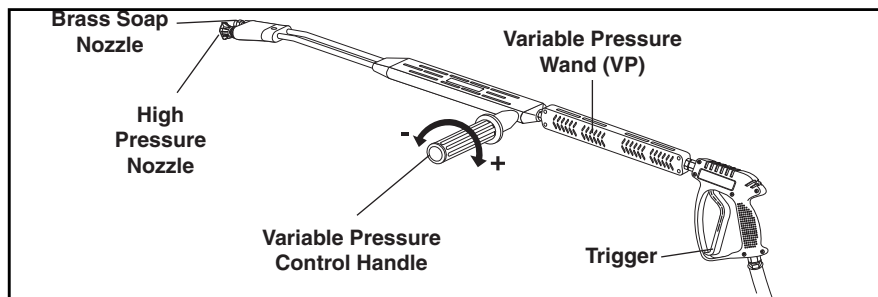

STEP 6: Selection of high or low pressure is accompanied by turning the handle. **NOTE:** High pressure nozzle must be inserted at end of wand to obtain high pressure.

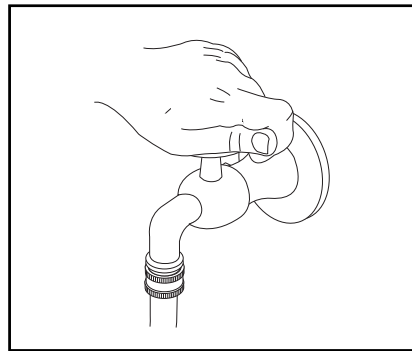

STEP 2: Turn on water at faucet and pull trigger on spray gun allowing water to flow until all air has discharged from system. Check for water leaks; tighten as needed. **NOTE:** Variable pressure control wand handle must be turned clockwise to enable water to flow out of the high pressure nozzle.

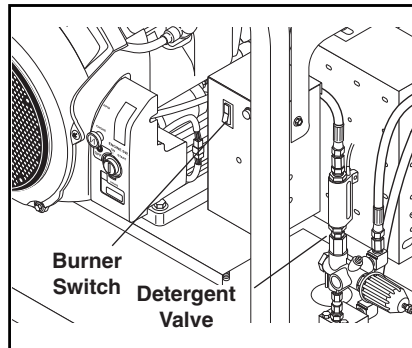

STEP 5: For hot water, turn the burner switch to ON when a steady stream of water flows out of the spray gun. Burner will now light automatically. **NOTE:** Do not start machine with burner switch on.

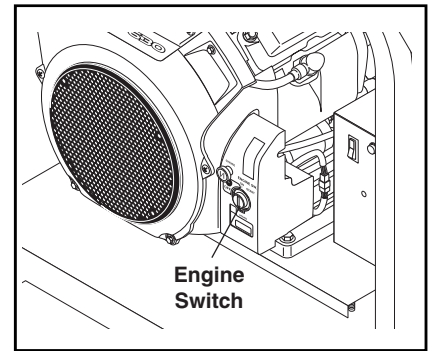

STEP 3: Read engine manual. Move fuel valve to closed or OFF position, if equipped. To start engine, if choke is closed, gradually move it to the open position as the engine warms up. Turn the engine switch to the START position and hold it there until the engine starts.

NOTE: Do not use the electric starter for more than five seconds at a time. If the engine fails to start, release the switch and wait ten seconds before operating the starter again. When the engine starts, allow the engine switch to return to the ON position. If the engine is to be started without the battery, turn switch to start position and pull rope to start. Turn off choke.

WARNING: Small engines may kick back. Do not hold pull rope tightly in hand. Starter cord kickback (rapid retraction) can result in bodily injury.

AVERTISSEMENT: Les petits moteurs peuvent présenter un risque de retour. Ne pas tenir fermement le lanceur moteur. Le retour du cordon de lancement (rétraction rapide) peut causer des lésions corporelles.

NOTE: Kick back will pull hand and arm toward engine faster than you can let go. Always relieve spray gun pressure before pulling starter cord. Pull starter cord slowly until resistance is felt, then pull rapidly.

Operations

Detergents & General Cleaning Techniques



WARNING: Some detergents may be harmful if inhaled or ingested, causing severe nausea, fainting or poisoning. The harmful elements may cause property damage or severe injury.

AVERTISSEMENT: Certains détergents peuvent être dangereux s'ils sont inhalés ou ingérés, provoquant de fortes nausées, des évanouissements et l'empoisonnement. Les éléments dangereux peuvent causer des dommages à la propriété ou des blessures graves.

STEP 1: Use detergent designed specifically for pressure washers. Household detergents could damage the pump. Prepare detergent solution as required by the manufacturer. Fill a container with pressure washer detergent. Place the filter end of detergent suction tube into the detergent container.

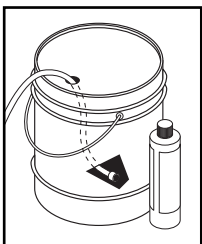

STEP 2: Apply safety latch to spray gun trigger. Secure black detergent nozzle into quick coupler.

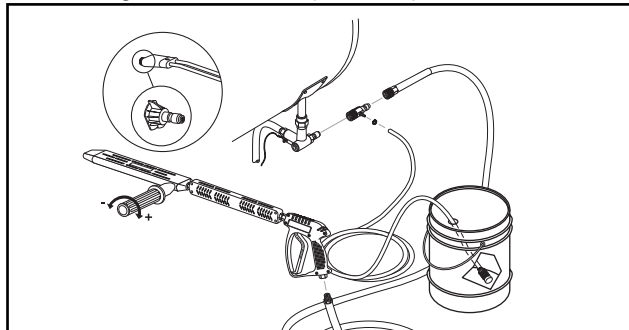

NOTE: Detergent cannot be applied using the Yellow nozzle.

STEP 3: Selection of high or low pressure is accompanied by turning the handle. **NOTE:** High pressure nozzle must be inserted at end of wand to obtain high pressure. To apply soap connect detergent injector to discharge nipple and secure by pushing coupler collar forward. Turn handle to lower pressure (water will exit both nozzles). Place detergent pick-up tube into detergent container. Rinse by turning handle for high pressure.

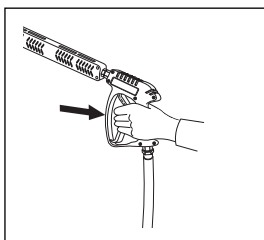

STEP 4: With the engine running, pull trigger to operate machine. Liquid detergent is drawn into the machine and mixed with water. Apply detergent to work area. Do not allow detergent to dry on surface.

IMPORTANT: You must flush the detergent injection system after each use by placing the suction tube into a bucket of clean water, then run the pressure washer in low pressure for 1-2 minutes.

Thermal Pump Protection

If you run your pressure washer for 3-5 minutes without pressing the trigger on the spray gun, circulating water in the pump can reach high temperatures. When the water reaches this temperature, the pump protector engages and cools the pump by discharging the warm water onto the ground. This thermal device prevents internal damage to the pump.

Cleaning Tips

Pre-rinse cleaning surface with fresh water. Place detergent suction tube directly into cleaning solution and apply to surface at low pressure (for best results, limit your work area to sections approximately 6 feet square and always apply detergent from bottom to top). Allow detergent to remain on surface 1-3 minutes. Do not allow detergent to dry on surface. If surface appears to be drying, simply wet down surface with fresh water. If needed, use brush to remove stubborn dirt. Rinse at high pressure from top to bottom in an even sweeping motion keeping the spray nozzle approximately 1 foot from cleaning surface. Use overlapping strokes as you clean and rinse any surface. For best surface cleaning action spray at a slight angle.

Recommendations:

- Before cleaning any surface, an inconspicuous area should be cleaned to test spray pattern and distance for maximum cleaning results.
- If painted surfaces are peeling or chipping, use extreme caution as pressure washer may remove the loose paint from the surface.
- Keep the spray nozzle a safe distance from the surface you plan to clean. High pressure wash a small area, then check the surface for damage. If no damage is found, continue to pressure washing.

CAUTION - Never use:

- Bleach, chlorine products and other corrosive chemicals
- Liquids containing solvents (i.e., paint thinner, gasoline, oils)
- Tri-sodium phosphate products
- Ammonia products or acid-based products

These chemicals will harm the machine and will damage the surface being cleaned.

ATTENTION: Ne jamais utiliser :

- Eau de Javel, produits à base de chlore et autres produits chimiques corrosifs
- Liquides contenant des solvants (c.-à-d. diluant à peinture, essence, huiles, etc.)
- Produits à base de tripolyphosphate de sodium
- Ammoniac ou produits à base d'acide

Ces produits chimiques endommageront la machine et endommageront la surface étant nettoyée

Rinsing

It will take a few seconds for the detergent to clear. Apply safety latch to spray gun. Remove black soap nozzle from the quick coupler. Select and install the desired high pressure nozzle. **NOTE:** You can also stop detergent from flowing by simply removing detergent siphon tube from bottle.

Shutting Down And Clean-up

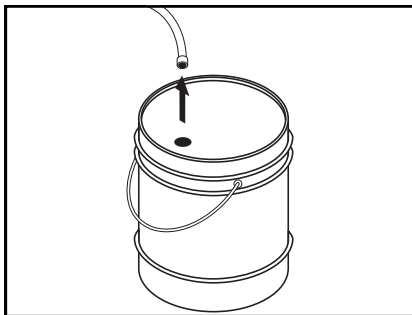

STEP 1: Remove detergent suction tube from container and insert into one (1) gallon of fresh water. Pull trigger on spray gun and siphon water for one minute.

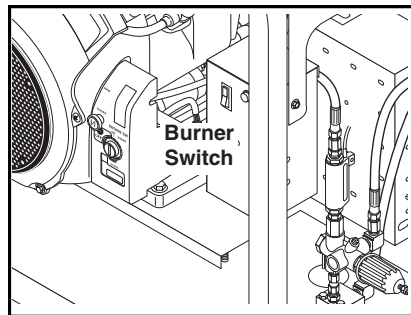

STEP 2: Turn burner switch off and continue spraying, allowing the water to cool to below 100°F.

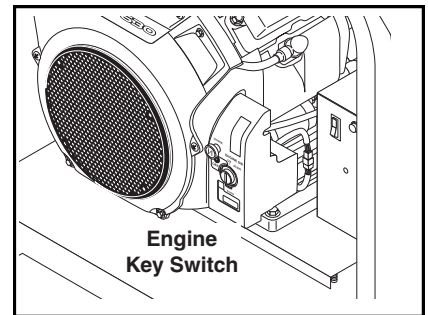

STEP 3: Turn engine key switch off and turn off water.

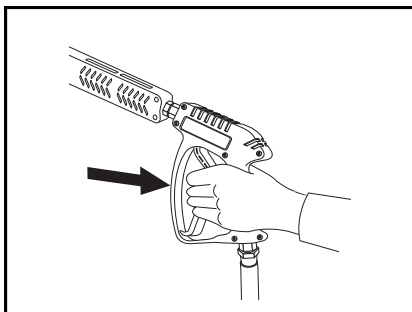

STEP 4: Squeeze trigger on spray gun to relieve remaining pressure.

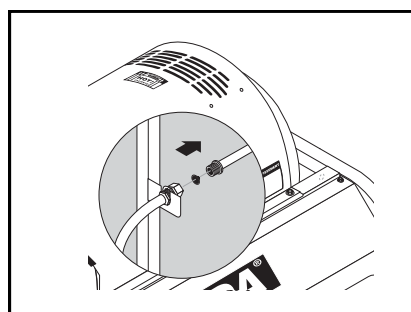

STEP 5: Remove water supply hose.

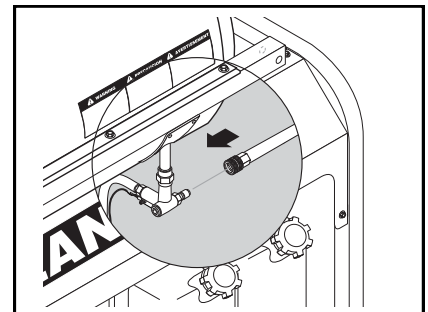

STEP 6: Disconnect high pressure hose from high pressure outlet.

Maintenance

Storage

CAUTION: Always store your pressure washer in a location where the temperature will not fall below 32°F (0°C). The pump in this machine is susceptible to permanent damage if frozen. **FREEZE DAMAGE IS NOT COVERED BY WARRANTY.**

ATTENTION: Toujours entreposer la laveuse à pression dans un endroit où la température ne sera pas inférieure à 32°C (0 °F). La pompe sur cette machine est susceptible de subir des dommages si elle est exposée au gel. **LES DOMMAGES DUS AU GEL NE SONT PAS COUVERTS PAR LA GARANTIE.**

1. Stop the pressure washer, squeeze spray gun trigger to release pressure.
2. Detach water supply hose and high pressure hose.
3. Turn on the machine for a few seconds, until remaining water exits. Turn engine off immediately.
4. Drain the gas and oil from the engine.
5. Do not allow high pressure hose to become kinked.
6. Store the machine and accessories in a room which does not reach freezing temperatures.

CAUTION: Failure to follow the above directions will result in damage to your pressure washer.

ATTENTION: Le non-respect des directives ci-dessus entraînera des dommages à la laveuse à pression.

When pressure washer is not being operated or is being stored for more than one month, follow these instructions:

1. Replenish engine oil to upper level.
2. Drain gasoline from fuel tank, fuel line, fuel valve and carburetor.
3. Pour about one teaspoon of engine oil through spark plug hole, pull starter grip several times and replace the plug. Then pull the starter grip slowly until you feel increased pressure which indicates the piston is on its compression stroke and leave it in that position. This closes both the intake and exhaust valves to prevent rusting of cylinder.
4. Cover pressure washer and store in a clean, dry place that is well ventilated away from open flame or sparks. **NOTE:** The use of a fuel additive, such as STA-BIL[®], or an equivalent, will minimize the formulation of fuel deposits during storage. Such additives may be added to gasoline in fuel tank of the engine, or to gasoline in a storage container.

After Extended Storage

CAUTION: Prior to restarting, thaw out any possible ice from pressure washer hoses, spray gun or wand.

ATTENTION: Avant de redémarrer, faire fondre la glace se trouvant sur les boyaux, le pistolet pulvérisateur ou la lance de la laveuse à pression.

Engine Maintenance

During the winter months, rare atmospheric conditions may develop which will cause an icing condition in the carburetor. If this develops, the engine may run rough, lose power and may stall. This temporary condition can be overcome by deflecting some of the hot air from the engine over the carburetor area. **NOTE:** Refer to the engine manufacturer's manual for service and maintenance of the engine.

1. Check to see that water pump is properly lubricated.
2. Follow winterizing instructions to prevent freeze damage to pump and coils.
3. Always neutralize and flush detergent from system after use.
4. If water is known to be high in mineral content, use a water softener on your water system, or de-scale as needed.
5. Do not allow acidic, caustic or abrasive fluids to be pumped through system.
6. Always use high grade quality cleaning products.
7. Never run pump dry for extended periods of time.
8. Use clean fuel-kerosene, No. 1 fuel oil, or diesel. Clean or replace fuel filter every 100 hours of operation. Avoid water contaminated fuel as it will damage the fuel pump.
9. If machine is operated with smoky or eye burning exhaust, coils will soot up, not letting water reach maximum operating temperature.
10. Never allow water to be sprayed on or near the engine or burner assembly or any electrical component.
11. Periodically delime coils as per instructions.
12. Check to see that engine is properly lubricated.

It is advisable, periodically, to visually inspect the burner. Check air inlet to make sure it is not clogged or blocked. Wipe off any oil spills and keep equipment clean and dry.

The flow of combustion and ventilating air to the burner must not be blocked or obstructed in any manner.

The area around the Landa washer should be kept clean and free of combustible materials, gasoline and other flammable vapors and liquids.

Unloader Valves

Unloader valves are preset and tested at the factory before shipping. Occasional adjustment of the unloader may be necessary to maintain correct pressure.

Winterizing Procedure

Damage due to freezing is not covered by warranty. Adhere to the following cold weather procedures whenever the washer must be stored or operated outdoors under freezing conditions.

During winter months, when temperatures drop below 32°F, protecting your machine against freezing is necessary. Store the machine in a heated room. If this is not possible then mix a 50/50 solution of anti-freeze and water in the float tank. Turn the engine on to siphon the anti-freeze mixture through the machine. If compressed air is available, an air fitting can be screwed into the float tank by removing the float tank strainer and fitting. Then inject the compressed air. Water will be blown out of the machine when the trigger on the spray gun is opened.

High Limit Hot Water Thermostat

For safety, each machine is equipped with a temperature sensitive high limit control switch. In the event that the water should exceed its operating temperature, the high limit control will turn the burner off until the water cools then automatically reset itself. The thermostat sensor is located on the discharge side of the heating coil. The thermostat control dial is located on the control panel.

Pumps

Use only SAE 10W-40 weight non-foaming oil. Change oil after first 50 hours of use. Thereafter, change oil every year or at 500 hour intervals. Oil level should be checked through use of dipstick found on top of pump, or the red dot visible through the oil gauge window. Oil should be maintained at that level.

Cleaning of Coils

In alkaline water areas, lime deposits can accumulate rapidly inside the heating coil. This growth is increased by the extreme heat build up in the coil. The best preventative for liming conditions is to use high quality cleaning detergents. In areas where alkaline water is an extreme problem, periodic use of Landa Coil Descaler (part #8.914-296.0) will remove lime and other deposits before coil becomes plugged.

Periodic descaling of the heating coil is recommended so please consult your local Landa Dealer for instruction.

Removal of Soot and Heating Coil

In the heating process, fuel residue in the form of soot deposits may develop between the heating coil pipe and block air flow which will affect burner combustion. When soot has been detected on visual observation, the soot on the coil must be washed off after following the coil removal steps (See Coil Removal).

Rupture Disk

If pressure from pump or thermal expansion should exceed safe limits, the rupture disk will burst allowing high pressure to be discharged through hose to ground. When disk ruptures it will need to be replaced. Rupture Disk should be replaced every two years.

Fuel

Use clean fuel oil that is not contaminated with water and debris. Replace fuel filter and drain tank every 100 hours of operation. Use No. 1 or No. 2 Heating Oil (ASTM D306) only. NEVER use gasoline in your burner tank. Gasoline is more combustible than fuel oil and could result in a serious explosion. NEVER use crankcase or waste oil in your burner. Fuel unit malfunction could result from contamination.

Maintenance

Fuel Control System

These machines utilize a fuel solenoid valve located on the fuel pump to control the flow of fuel to the combustion chamber. This solenoid valve, which is normally closed, is activated by a flow switch when water is flowing through it. When an operator releases the trigger on the spray gun, the flow of water through the flow switch stops, turning off the current to the fuel solenoid. The solenoid then closes, shutting off the supply of fuel to the combustion chamber. Controlling the flow of fuel in this way allows for an instantaneous burn or no burn situation, thereby eliminating high and low water temperatures, and combustion smoke normally associated with units incorporating a spray gun.

CAUTION: Periodic inspection is recommended to insure that the fuel solenoid valve functions properly. This can be done by operating the machine and checking to see that when the trigger on the spray gun is in the off position, the burner is not firing.

Fuel Pressure Adjustment

To adjust fuel pressure, first install a pressure gage into the port just after the pump fuel exit. Turn the adjusting screw (located at the regulator port) clockwise to increase, and counterclockwise to decrease. Do not exceed 200 psi or lower the pressure below 130 PSI, when checked at the post-pump pressure port.

The fuel pressure may need to be adjusted due to altitude. For every 500 ft altitude above sea level, the boiling point of water goes down 1 °F. At high altitude environments, this boiling point change may require the heat input to be lowered so the water input does not turn to steam earlier than at the factory settings and activate the pressure sensors and pressure relief equipment when the unit is operated and much higher altitudes from factory settings or local dealer site settings. Check with your dealer before making local site fuel pressure adjustments.

Also, as ambient temperature changes seasonally, the fuel temperature in the feed tank and air temperature inlet can impact fuel flow. In more extreme temperatures, this local-site adjustment may also require different fuel nozzles for fuel inlet temperatures that are at seasonal extremes (higher or lower) in locations where the temperature changes are beyond moderate temperatures of between 40°F and 90°F. Colder temperatures will make for a thicker flow and less fine a fuel spray while hotter temperatures will make for a thinner flow a more fine spray with the same nozzle. Consider alternate nozzle configurations from the

baseline factory-supplied nozzle for operating in such temperature extremes if performance is not meeting needs with air band and fuel pressure settings alone.

NOTE: When changing fuel pump, a by-pass plug must be installed in return line port or fuel pump will not prime.

Electrode Setting

Burner Nozzle

Keep the tip free of surface deposits by wiping it with a clean, solvent-saturated cloth, being careful not to plug or enlarge the nozzle. For maximum efficiency, replace the nozzle each season.

Gun Setting Instructions For EHASR Only

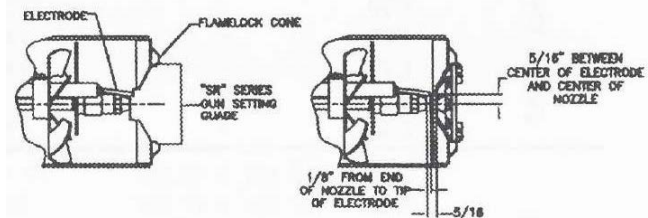

**SR-Series gage KNA Part
Number 8.717-379.0**

Burner Air Adjustment

The oil burner on this machine is preset for operation at altitudes below 500 feet. If operated at higher altitudes, it may be necessary to adjust the air band for a #1 or #2 smoke spot on the Bacharach scale.

To adjust, start machine and turn burner ON. Loosen two locking screws found on the air band and close air band until black smoke appears from burner exhaust vent. Note air band position. Next, slowly open the air band until white smoke just starts to appear. Turn air band halfway back to the previously noted position. Tighten locking screws.

For higher altitudes, the air band opening may need to be increased; for lower altitude, the air band may need to be decreased.

For higher humidity, the air band opening may need to be increased; for lower relative humidity, the air band may need to be decreased.

For higher ambient temperatures the air band opening may need to be increased; for lower ambient temperatures, the air band opening may need to be decreased.

Adjust to your operating location's environment as-needed for best smoke spot and performance compliant with local, state, and federal regulations.

CAUTION: If white smoke appears from burner exhaust vent during start-up or operation, discontinue use and readjust air bands.

ATTENTION: Si de la fumée blanche s'échappe de l'évacuation du brûleur pendant le démarrage ou le fonctionnement, cesser d'utiliser et réajuster les bandes d'air.

NOTE: If a flue is installed, have a professional serviceman adjust your burner for a #1 or #2 smoke spot on the Bacharach scale.

Coil Removal

Removal of coil, because of freeze breakage or to clean soot from it, can be done quickly and easily.

1. Disconnect hose from pump to inlet side of the coil.
2. Carefully disconnect thermostat sensor from electrical connection.
3. Remove all the fittings from the inlet and discharge side of coil.
4. Remove the burner assembly from the combustion chamber.
5. Remove the 3-3/8" bolts from each side of coil and tank assembly (these bolts are used to fasten tank to chassis).
6. Remove the two bolts which are underneath the bottom wrap (to keep the coil from moving.)
7. Remove tank top wrap exposing insulation and coil.
8. Bend back insulation tabs.
9. Carefully fold back the insulation and remove insulation retainer plates and coil.
10. Replace or repair coil and any insulation found to be torn or broken.
11. Reinstall 1/2" pipe nipples into coil.

Coil Reinstallation

Reinstall new or cleaned coil by reversing Steps 9 through 1.

Final Note

The 12 VDC burner systems can draw as much as 18 amps! For such motors to run properly, the battery and engine charging system must be kept in good condition, and the engine must run fast enough to adequately charge the battery. Do not throttle down the engine at any time while the machine is operating.

Maintenance

Troubleshooting

PROBLEM	POSSIBLE CAUSE	SOLUTION
LOW OPERATING PRESSURE	Faulty pressure gauge	Install new gauge.
	Insufficient water supply	Use larger supply hose; clean filter at water inlet.
	Old, worn or incorrect spray nozzle	Match nozzle number to machine and/or replace with new nozzle.
	Belt slippage	Tighten or replace; use correct belt.
	Plumbing or hose leak	Check plumbing system for leaks. Re-tape leaks with teflon tape.
	Faulty or mis-adjusted unloader valve	Adjust unloader for proper pressure. Install repair kit when needed.
	Worn packing in pump	Install new packing kit.
	Fouled or dirty inlet or discharge valves in pump	Clean inlet and discharge valves.
	Worn inlet or discharge valves	Replace with valve kit.
	Obstruction in spray nozzle	Remove obstruction.
	Leaking pressure control valve	Rebuild or replace as needed.
	Slow engine RPM	Set engine speed at proper specifications.
	Pump sucking air	Check water supply and possibility of air seepage.
	Valves sticking	Check and clean or replace if necessary.
	Unloader valve seat faulty	Check and replace if necessary.
BURNER WILL NOT LIGHT	Little or no fuel	Fill tank with fuel.
	Improper fuel or water in fuel	Drain fuel tank and fill with proper fuel.
	Clogged fuel line	Clean or replace.
	Plugged fuel filter	Replace as needed.
	Mis-adjusted burner air bands	Readjust air bands for clean burn.
	Little or no fuel pressure from fuel pump	Increase fuel pressure to specification and/or replace fuel pump. Test with pressure gauge.
	Faulty burner transformer	Test transformer for proper arc between contacts. Replace as needed.
	30 amp circuit breaker tripped	Push reset button
	Bridge rectifier defective	Test and replace
	12 VDC relay defective	Test and replace
(continued on next page)	Disconnected or short in electrical wiring	All wire contacts should be clean and tight. No breaks in wire

PROBLEM	POSSIBLE CAUSE	SOLUTION
BURNER WILL NOT LIGHT (continued from previous page)	Flex coupling slipping on fuel pump shaft or burner motor shaft	Replace if needed.
	On-Off switch defective	Check for electrical current reaching burner assembly with burner switch on.
	Heavy sooting on coil and burner can cause interruption of air flow and shorting of electrodes	Clean as required.
	Improper electrode setting	Check and reset according to diagram in Operator's Manual.
	Fuel not reaching combustion chamber	Check fuel pump for proper flow. Check solenoid flow switch on machines with spray gun control, for proper on-off fuel flow control.
	Clogged burner nozzle	Clean as required.
	Thermostat faulty or slow engine speed	Increase engine RPM to increase voltage.
	Flow switch malfunction	Remove, test for continuity and replace as needed.
	Flow solenoid malfunction	Replace if needed.
FLUCTUATING PRESSURE	Valves worn	Check and replace if necessary.
	Blockage in valve	Check and replace if necessary.
	Pump sucking air	Check water supply and air seepage at joints in suction line.
	Worn piston packing	Check and replace if necessary.
MACHINE SMOKES WHILE BURNER UNIT IS RUNNING OR UNIT SMOKES AT COLD-START ONLY WHEN BURNER IS OFF	Improper fuel or water in fuel	Drain tank and replace contaminated fuel.
	Improper air adjustment	Readjust air bands on burner assembly.
	Fuel pressure is low <140 psi for burner	Adjust fuel pump pressure to specifications.
	Plugged or dirty burner nozzle	Replace nozzle. Check parts breakdown for nozzle size
	Faulty burner nozzle spray pattern	Replace nozzle. Check parts breakdown for nozzle size.
	Heavy accumulation of soot on coils and burner assembly	Remove coils and burner assembly, clean thoroughly. Call local dealer.
	Misaligned electrode setting	Realign electrodes to specifications.
	Obstruction in smoke stack	Check for insulation blockage or other foreign objects.
	Low engine RPM	Increase RPM to correct specs. See serial plate.
Fuel Pressure is too high for clean burn (fuel PSI above 140 and below 200) and smokes when burner is off	Reduce fuel pressure PSI/Increase air band set for cleaner without max water heat loss	

Maintenance

PROBLEM	POSSIBLE CAUSE	SOLUTION
LOW WATER TEMPERATURE	Improper fuel or water in fuel	Replace with clean and proper fuel.
	Low fuel pressure	Increase fuel pressure.
	Weak fuel pump	Check fuel pump pressure. Replace pump if needed.
	Fuel filter partially clogged	Replace as needed.
	Soot build-up on coils not allowing heat transfer	Clean coils.
	Improper burner nozzle	See specifications pages
WATER TEMPERATURE TOO HOT	Incoming water to machine warm or hot	Lower incoming water temperature.
	Fuel pump pressure too high	See specifications for proper fuel pressure.
	Fuel pump defective	Replace fuel pump.
	Detergent line sucking air	Tighten all clamps. Check detergent lines for holes
	Defective temperature switch	Replace.
	Incorrect fuel nozzle size	See specifications for proper fuel nozzle.
	Insufficient water supplied	Check water G.P.M. to machine.
	Restricted water flow	Check nozzle for obstruction, proper size.
PUMP NOISY	Air in suction line	Check water supply and connections on suction line.
	Broken or weak inlet or discharge valve springs	Check and replace if necessary.
	Excessive matter in valves	Check and clean if necessary.
	Worn bearings	Check and replace if necessary.
PRESENCE OF WATER IN OIL	Oil seal worn	Check and replace if necessary.
	High humidity in air	Check and change oil twice as often.
WATER DRIPPING FROM UNDER PUMP	Piston packing worn	Check and replace if necessary.
	O-Ring plunger retainer worn	Check and replace if necessary.
	Cracked piston	Check and replace if necessary.
	Pump protector	Lower water supply pressure. Do not run with spray gun closed longer than 2 minutes.

PROBLEM	POSSIBLE CAUSE	SOLUTION
OIL DRIPPING	Oil seal worn	Check and replace if necessary.
EXCESSIVE VIBRATION IN DELIVERY LINE	Irregular functioning of the valves	Check and replace if necessary.
DETERGENT NOT DRAWING FROM SOURCE	Air leak	Tighten all clamps. Check detergent lines for holes.
	Restrictor in float tank is missing	Replace restrictor. Check for proper orifice in restrictor.
	Filter screen on detergent suction hose plugged	Clean or replace.
	Dried up detergent plugging metering valve	Disassemble and clean thoroughly
	High viscosity of detergent	Dilute detergent to specifications.
	Hole in detergent line(s)	Repair hole.
	Low detergent level	Add detergent, if needed.
PUMP RUNNING NORMALLY BUT PRESSURE LOW ON INSTALLATION	Pump sucking air	Check water supply and possibility of air seepage.
	Valves sticking	Check and clean or replace if necessary.
	Nozzle incorrectly sized	Check and replace if necessary (See serial plate for proper size).
	Unloader valve seat faulty	Check and replace if necessary.
	Worn piston packing	Check and replace if necessary.
BURNER MOTOR WILL NOT RUN	Fuel pump seized	Replace fuel pump.
	Burner fan loose or misaligned	Position correctly, tighten set screw.
	Defective control switch	Replace switch.
	Loose wire	Check and replace or tighten wiring.
	Defective burner motor	Replace motor.
RELIEF VALVE LEAKS WATER	Relief valve defective	Replace or repair.

Maintenance

Preventative Maintenance

This pressure washer was produced with the best available materials and quality craftsmanship. However, you as the owner, have certain responsibilities for the correct care of the equipment. Attention to regular preventative maintenance procedures will assist in preserving the performance of your equipment. Contact your Landa dealer for maintenance. Regular preventative maintenance will add many hours to the life of your pressure washer. Perform maintenance more often under severe conditions.

Maintenance Schedule		
Pump Oil (Non-foaming) SAE 10W-40	Inspect	Oil level daily
	Change	After first 50 hours, then every 500 hours or annually
Replace High Pressure Nozzle		Every 6 months
Replace Quick Connects		Annually
Clean Water Screen/Filter		Weekly
Replace HP Hose		Annually
Rupture Disk		Replace every 2 years

Parts

LANDA PGDC

PGDC4 - 3500
1.110-049.0

PGDC5 - 3500
1.110-050.0

PGDC5 - 3500
1.110-051.0

PGDC8 - 3000
1.110-072.0

PGDC5 - 3500
1.110-096.0

PGDC8 - 3000
1.110-098.0

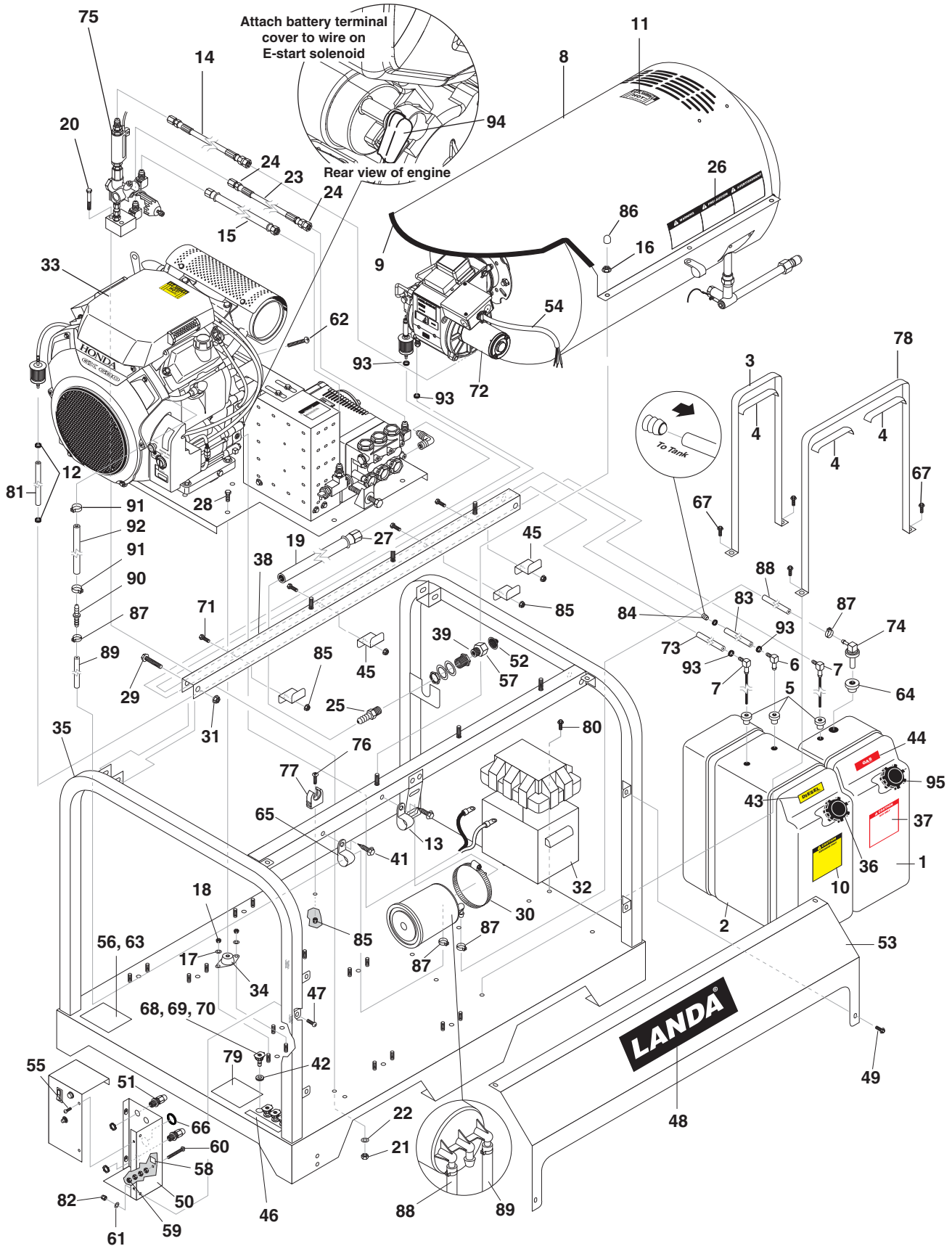

REF	PART NO.	QTY	DESCRIPTION	NOTES
1	8.758-282.0	1	TANK, FUEL, 4.75 GALLON, LOW-PERM	ALL BUT 1.110-049.0
2	8.752-187.0	1	TANK, DIESEL, 9.25 GAL	
3	8.921-148.0	2	STRAP, FUEL TANK SINGLE	1.110-049.0
-	-	1	STRAP, FUEL TANK SINGLE -	ALL BUT 1.110-049.0
4	9.802-193.0	2	GASKET, NEOPRENE SC41-W/PSA, PER FT.	1.110-049.0
-	-	3	GASKET, NEOPRENE SC41-W/PSA, PER FT.	ALL BUT 1.110-049.0
5	9.802-053.0	2	BUSHING, RUBBER, NITRILE	1.110-049.0
-	-	3	BUSHING, RUBBER, NITRILE	ALL BUT 1.110-049.0
6	9.802-054.0	1	ELBOW, FUEL TANK, ZINC	
7	8.706-496.0	1	DIPTUBE ASSY, PLASTIC, 17.5"	1.110-049.0
-	-	2	DIPTUBE ASSY, PLASTIC, 17.5"	ALL BUT 1.110-049.0
8	8.912-192.0	1	TOP WRAP, STAINLESS STEEL	
9	9.802-071.0	33"	TRIM, 750 B2 X 1/16 BLACK	
10	8.758-339.0	1	LABEL, USE ONLY KEROSENE	
11	8.758-328.0	1	LABEL, HOT/CALIENTE W/ARROWS	
12	6.390-126.0	2	HOSE CLAMP	ALL BUT 1.110-049.0
13	9.802-204.0	1	CLAMP, WIRE/TUBE, .75 DIA	
14	8.918-426.0	1	HOSE, 3/8" X 32", 2 WIRE PRESSURE LO	1.110-049.0, 1.110-050.0, 1.110-051.0
-	8.918-227.0	1	HOSE, 1/2" X 36", 2 WIRE, PRESSURE LO	1.110-072.0
15	8.918-425.0	1	HOSE, 3/8" X 29", 2 WIRE, PRESSURE LO	1.110-049.0, 1.110-050.0, 1.110-051.0
-	8.918-225.0	1	HOSE, 1/2" X 28", 2 WIRE, PRESSURE LO	1.110-072.0
16	9.802-781.0	6	NUT, 3/8" WHIZ	
17	8.718-980.0	18	WASHER, 5/16" FLAT, SAE	ALL EXCEPT 1.110-096.0 & 1.110-098.0
-	8.718-980.0	22	WASHER, 5/16" FLAT, SAE	1.110-096.0, 1.110-098.0
18	9.802-776.0	18	NUT, 5/16" ESNA, NC	
19	9.802-261.0	39"	HOSE, 3/4"	
20	9.802-728.0	2	BOLT, 3/8-16 x 2", HH ZINC	1.110-049.0, 1.110-050.0, 1.110-051.0
-	9.802-730.0	2	BOLT, 3/8" X 2-1/2" GR 5 ZINC	1.110-072.0
21	9.802-779.0	2	NUT, 3/8"	
22	9.802-807.0	2	WASHER, FLAT, 3/8"	
23	9.802-259.0	24"	HOSE, 1/2" PUSH-ON	
-	-	24"	HOSE, 1/2" PUSH-ON	1.110-072.0
24	9.802-151.0	2	SWIVEL, 1/2" JIC FEM PUSH-ON	
-	-	2	SWIVEL, 1/2" JIC FEM PUSH-ON	1.110-072.0
25	8.757-505.0	1	HOSE BARB BRASS 3/4" BARB X 1/2"	
26	8.758-391.0	1	LABEL, PGHW SKID WARNING	
27	9.802-152.0	1	SWIVEL, 3/4" SAE FEM, PUSH-ON	
28	9.802-767.0	9	SCREW, 3/8" X 3/4" HH, NC, WHIZ	ALL EXCEPT 1.110-096.0 & 1.110-098.0
-	9.802-767.0	11	SCREW, 3/8" X 3/4" HH, NC, WHIZ	1.110-096.0, 1.110-098.0

REF	PART NO.	QTY	DESCRIPTION	NOTES
29	8.718-674.0	2	BOLT, 3/8-16 X 2-1/4", GR8.2 SERATED FLANGE B	
30	8.752-918.0	1	CLAMP, HOSE #64SS	
31	9.802-781.0	2	NUT, 3/8" FLANGE WHIZ LOC NC	
32	8.706-600.0	1	BATTERY, M-100, LARGE	
33	8.916-471.0	1	ASSY, POWER PLATFORM PGDC5-3500	
34	8.932-992.0	9	MOUNT, RUBBER VIBRATION. 3/8" 70 DURO	ALL EXCEPT 1.110-096.0 & 1.110-098.0
-	8.932-992.0	11	MOUNT, RUBBER VIBRATION. 3/8" 70 DURO	1.110-096.0, 1.110-098.0
35	8.920-485.0	1	WLMT, SKID, PGDC	
36	9.802-089.0	1	CAP, TANK	
37	8.758-350.0	1	LABEL, THIS TANK FOR GAS ONLY	
38	8.920-295.0	1	SUPPORT, COIL, SKID	
39	8.707-000.0	1	CONNECTOR, 1/2" ANCHOR	
40	9.802-781.0	8	NUT, 3/8 FLANGE WHIZ	NOT SHOWN
41	9.802-797.0	2	SCREW, #10 X 1/2" HEX HEAD SS	
42	9.802-064.0	4	GROMMET, RUBBER NOZZLE HOLDER	
43	8.758-341.0	1	LABEL, DIESEL, BLACK ON YELLOW	
44	8.758-388.0	1	LABEL, GAS WHITE ON RED	
45	8.759-732.0	4	BRACKET FUEL LINE	
46	8.758-482.0	1	LABEL NOZZLE 0 15 25 40	
47	9.802-753.0	2	SCREW, 1/4" X 3/4"	
48	8.758-389.0	1	LABEL LANDA LOGO 21" X 4.75"	
49	9.803-277.0	4	SCREW, 5/16 X 1/2 WHIZ LOC	
50	8.916-443.0	1	WLMT, BACK ELECTRICAL, PGDC	
51	9.802-514.0	2	STRAIN RELIEF, LT., STR., 1/2 NPT .23-45D	
52	9.804-016.0	1	FILTER SCREEN WASHER, GARDEN HOSE/ 30MESH	
53	8.916-619.0	1	PANEL, PGDC	
54	8.925-591.0	1	HARNESS BURNER PGDC	
55	9.802-765.0	4	SCREW, 1/4" X 1/2"	
56	8.758-336.0	1	LABEL ASSEMBLED IN USA OUTDOOR USE	
57	8.757-203.0	1	SWIVEL, 1/2" M-NPTF x 3/4" GHF	
58	8.758-327.0	1	LABEL GROUND SYMBOL	
59	9.802-695.0	4	NUT, 10/32" KEPS	
60	9.802-762.0	1	SCREW, 10/32" X 1-1/4" RH, SL, BLK	
61	9.802-802.0	2	WASHER, 1/4", FLAT, SAE	
62	8.718-781.0	1	SCREW, 40MM, PAN HD	
63	8.758-330.0	1	LABEL CLEAR LEXAN 4.30" X 5.50"	
64	8.751-215.0	1	GROMMET, REMOTE VENT	
65	8.709-089.0	1	CLAMP, "WIRE/TUBE .6250"	
66	8.706-735.0	1	BUSHING, 1-1/4" SNAP	
67	9.802-768.0	4	SCREW, 3/8" x 1-1/4", WHIZ LOC FLANGE	
68	8.712-354.0	1	NOZZLE, SAQCMEG 1505, YELLOW	1.110-050.0, 1.110-051.0
-	8.712-379.0	1	NOZZLE, SAQCMEG, 1509	1.110-072.0
-	8.712-346.0	1	NOZZLE, SAQCMEG 1504, YELLOW	1.110-049.0

REF	PART NO.	QTY	DESCRIPTION	NOTES
69	8.712-355.0	1	NOZZLE, SAQCMEG 2505, GREEN	1.110-050.0, 1.110-051.0
-	8.712-380.0	1	NOZZLE SAQC MEG, 2509	1.110-072.0
-	8.712-347.0	1	NOZZLE, SAQCMEG 2504, GREEN	1.110-049.0
70	8.712-356.0	1	NOZZLE, SAQCMEG 4005, WHITE	1.110-050.0, 1.110-051.0
-	8.712-381.0	1	NOZZLE, SAQC MEG, 4009	1.110-072.0
-	8.712-348.0	1	NOZZLE, SAQCMEG 4004, WHITE	1.110-049.0
71	9.802-759.0	4	SCREW, 10/32" x 1/2" BHSOC BLK	
72	-	1	BURNER ASSY	SEE SPECIFICATIONS PAGE
73	9.802-254.0	90"	HOSE 1/4"	
74	8.751-059.0	1	VENT, REMOTE ASSY	
75	8.916-479.0	1	ASSY, UNLOADER, PGDC	1.110-049.0, 1.110-050.0, 1.110-051.0
-	8.925-188.0	1	ASSY, UNLOADER, PGDC, 8-30	1.110-072.0
76	9.802-771.0	1	SCREW, 10/32 X 3/4	
77	9.802-203.0	1	CLAMP, 1/2" RO-CLIP	
78	8.921-147.0	1	STRAP, FUEL TANK, DOUBLE	16HP, 20HP MODELS
79	8.758-361.0	1	LABEL LANDA SKID OPERATING INSTRUCTIONS	
80	9.802-708.0	2	SCREW, 5/16-18 X 3/4, M PH TRH	
81	9.802-254.0	74"	HOSE 1/4"	ALL EXCEPT 1.110-050.0
-	9.802-254.0	90"	HOSE 1/4"	1.110-050.0
82	9.802-773.0	2	NUT, 1/4", ESNA, NC	
83	9.802-254.0	90"	HOSE 1/4"	
84	8.754-911.0	1	CHECK VALVE, 1 WAY, 1/4" BARB	
85	9.802-695.0	5	NUT, 10/32 KEP	
86	8.750-435.0	6	CAP, BLACK VINYL	
87	8.753-066.0	4	CLAMP, 1 EAR, #7	
88	9.802-254.0	13"	HOSE, 1/4"	ALL EXCEPT 1.110-049.0
89	9.802-254.0	57"	HOSE, 1/4"	ALL EXCEPT 1.110-049.0
90	8.753-270.0	1	REDUCER CONNECTOR 3/8" X 1/4"	
91	8.753-065.0	2	CLAMP, 1 EAR, #10	
92	8.711-785.0	6"	HOSE, 3/8" PUSH-ON	
93	8.709-069.0	4	CLAMP, SCREW, 5/16"W, 1/4-5/8" D, SS	
94	9.804-615.0	1	COVER, BATTERY TERMINAL, RED	(HONDA ONLY)
95	8.750-674.0	1	CAP,RATCHET 225,NON-VENT,UNLEADED,CARB	1.110-050.0, 1.110-051.0, 1.110-072.0
96	9.802-710.0	4	SCREW 5/16" X 1" NC	NOT SHOWN (1.110-096.0, 1.110-098.0)

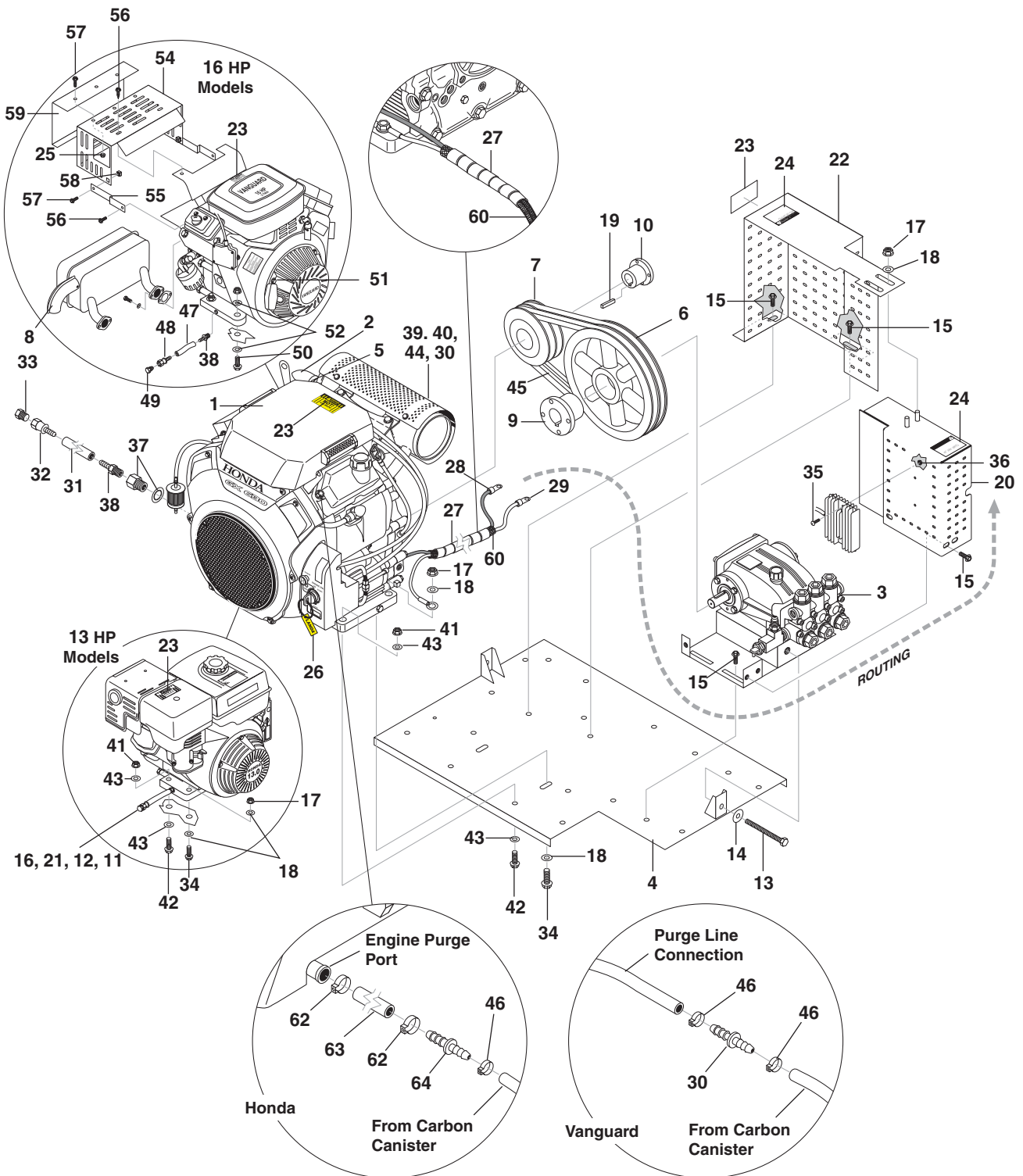

REF	PART NO.	QTY	DESCRIPTION	NOTES
1	-	-	ENGINE	SEE SPECIFICATIONS PAGE
2	8.915-387.0	1	DEFLECTOR, EXHAUST, 1.375" D PIPE, 45DEG	HONDA
3	-	-	PUMP	SEE SPECIFICATIONS PAGE
4	8.916-442.0	1	WLMT, PLATFORM PGDC	ALL EXCEPT 096.0 & 098.0
-	8.931-555.0	1	WELDED ASSEMBLY POWER PLATFORM	1.110-096.0 & 1.110-098.0
5	9.802-798.0	1	SCREW, #10 X 1/2", TEK HEX HEAD	HONDA
6	-	-	PUMP PULLEY	SEE SPECIFICATIONS PAGE
7	-	-	ENGINE PULLEY	SEE SPECIFICATIONS PAGE
8	8.718-028.0	1	MUFFLER DEFLECTOR	VANGUARD
9	-	-	PUMP BUSHING	SEE SPECIFICATIONS PAGE
10	-	-	ENGINE BUSHING	SEE SPECIFICATIONS PAGE
11	9.802-125.0	1	PLUG, 1/4" JIC	1.110-049.0
12	9.802-153.0	1	SWIVEL, 1/4" JIC FEM, PUSH-ON	1.110-049.0
13	9.803-845.0	1	BOLT, 1/2" X 5" NC HH TAP ALL THREAD	
14	9.802-800.0	1	WASHER, 1/2" FLAT	
15	9.802-767.0	9	SCREW, 3/8" X 3/4" HH, NC WHIZ	
16	9.802-154.0	1	PLUG, PUSH-ON, OIL DRAIN, HONDA	1.110-049.0
17	9.802-779.0	4	NUT, 3/8"	
18	9.802-807.0	6	WASHER, FLAT 3/8"	
19	9.802-673.0	1	KEY, SHAFT, 16 HP VANGUARD	
20	8.912-457.0	1	WLMT, BELT GUARD, GAS PUMP	1.110-050.0, 1.110-051.0
-	8.922-994.0	1	WLMT, BELT GUARD, 13 HP,	1.110-049.0
21	9.802-254.0	7"	HOSE, 1/4" 1.110-049.0	
22	8.916-610.0	1	GUARD, BELT, LEFT	ALL EXCEPT 096.0 & 098.0
-	8.931-557.0	1	BELT GUARD ENGINE - LONCIN	1.110-096.0 & 1.110-098.0
23	8.758-328.0	2	LABEL, HOT/CALIENTE W/ARROWS	
24	8.758-329.0	2	LABEL WARNING EXPOSED PULLEYS	
25	9.802-775.0	3	NUT, 1/4" FLANGE, ZN	1.110-050.0
26	8.913-902.0	1	KEY, RING LANDA	
27	9.802-445.0	8"	WRAP, SPIRAL	
28	8.753-358.0	1	CABLE, BATTERY, 61" EYE TO EYE, RED	
29	8.753-359.0	1	CABLE, BATTERY, 61" EYE TO EYE, BLACK	
30	8.753-269.0	1	REDUCER, CONNECTOR 1/4" X 3/16"	
31	9.802-259.0	8"	HOSE, 1/2" PUSH-ON	
32	9.802-151.0	1	SWIVEL, 1/2" JIC FEM, PUSH-ON	
33	9.802-126.0	1	PLUG, 1/2" JIC FLARE 639F-8"	
34	9.802-728.0	2	THREADED BOLT 3/8" X 2"	
35	9.802-771.0	2	SCREW, 10/32" X 3/4" BH SOC CS	HONDA
36	9.802-695.0	2	NUT, 10/32" KEPS	HONDA
37	8.750-737.0	1	ADAPTER, HONDA , M20-1.5 X 3/8"	HONDA
-	9.803-052.0		REDUCER, M14 TO 1/4" F	1.110-096.0 & 1.110-098.0
-	8.757-969.0		ELBOW STREET STEEL 1/4 NPTF-MX3/8 NPTF-F	1.110-096.0 & 1.110-098.0

Power Platform

REF	PART NO.	QTY	DESCRIPTION	NOTES
38	8.757-487.0	1	HOSE BARB BRASS 1/2" BARB X 3/8"	
39	8.750-497.0	1	MUFFLER, HONDA, RIGHT	ALL EXCEPT 096.0 & 098.0
40	8.739-597.0	2	BOLT, FLANGE, 8 X 20MM, GX610/620	ALL EXCEPT 096.0 & 098.0
41	8.725-319.0	2	NUT, 7.16-14 NYL, INS LN ZC	
42	8.725-320.0	2	BOLT, 7/16-14 X 2 HEX TAP GRD5 ZC	
43	9.802-809.0	4	WASHER, 1/2" FLAT, SAE	
44	9.803-008.0	1	SHIELD, HEAT, MUFFLER GUARD	
45	-	2	BELT	SEE SPECIFICATIONS PAGE
46	8.753-065.0	1	#7 CLAMP	HONDA
-	-	2	#7 CLAMP	VANGUARD
47	9.802-259.0	8"	HOSE, 1/2" PUSH-ON	1.110-050.0
48	9.802-151.0	1	SWIVEL, 1/2" JIC FEM, PUSH-ON	1.110-050.0
49	9.802-126.0	1	PLUG, 1/2" JIC FLARE, 639F-8"	1.110-050.0
50	9.802-716.0	4	BOLT, 5/16" X 2" NC HH	1.110-050.0
51	9.802-776.0	4	NUT, 5/16" ESNA, NC	1.110-050.0
52	8.718-980.0	8	WASHER, 5/16" FLAT SAE	1.110-050.0
53	9.802-672.0	1	MUFFLER, EXHAUST, BRIGGS	1.110-050.0
54	9.802-867.0	1	GUARD, MUFFLER, 16 HP VANGUARD	1.110-050.0
55	9.802-868.0	2	BRACE, VANGUARD, MUFFLER BRACKET	1.110-050.0
56	9.802-830.0	4	SCREW, HEX 1/4"-20 X 1/2" T/F TCS	1.110-050.0
57	9.802-754.0	5	SCREW, 1/4" X 1/2" HH, NC, WHIZ LOC	1.110-050.0
58	9.802-794.0	2	NUT, CAGE, 1/4" X 12 GA	1.110-050.0
59	9.803-011.0	1	SHIELD, HEAT, VANGUARD	1.110-050.0
60	8.716-011.0	48"	CONDUIT, FLEXP	
62	8.753-065.0	2	#10 CLAMP	HONDA
63	8.711-785.0	6"	HOSE, 3/8" PUSH-ON	
64	8.753-270.0	1	REDUCER, CONNECTOR 3/8" X 1/4"	

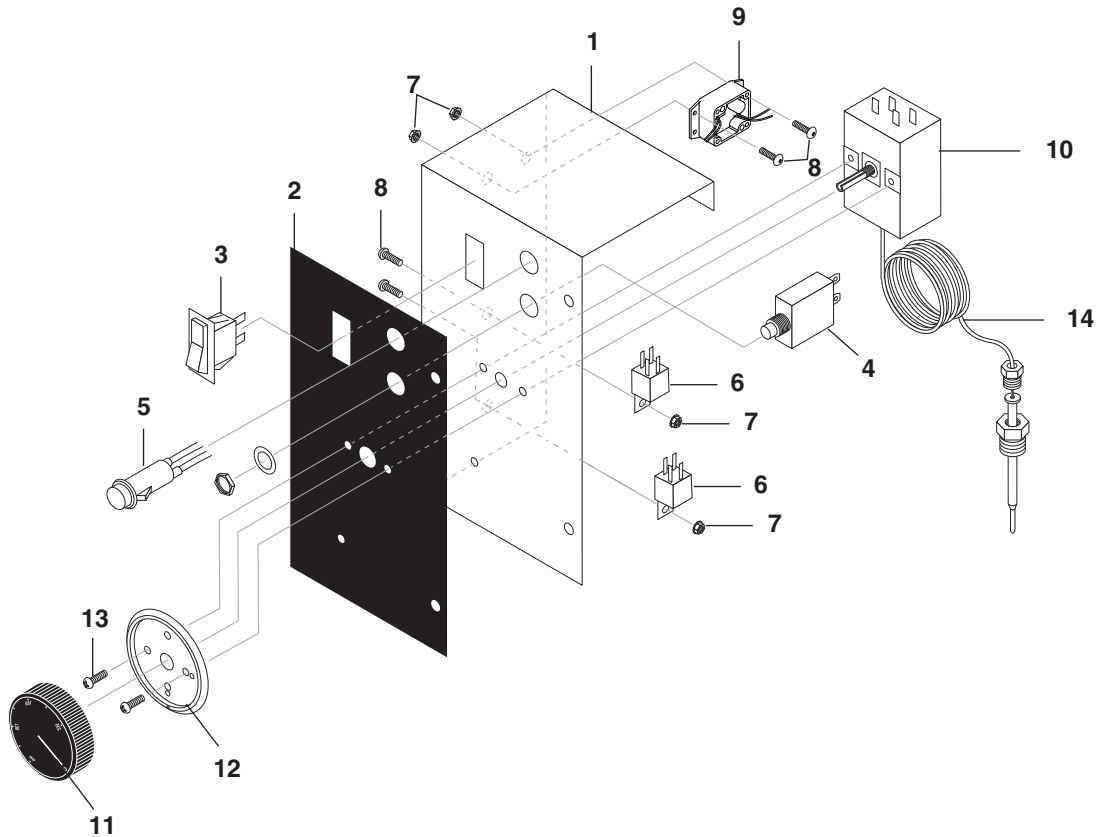

REF	PART NO.	QTY	DESCRIPTION	NOTES
1	8.916-458.0	1	CONTROL, FRONT, PGDC	
2	8.758-447.0	1	LABEL CONTROL PGDC	
3	9.802-453.0	1	SWITCH, CURVETTE	
4	9.802-485.0	1	BREAKER, CIRCUIT, 25 AMP	
5	9.802-456.0	1	LIGHT, INDICATOR, GREEN 12V	
6	9.802-470.0	2	RELAY, 12V	
7	9.802-695.0	4	NUT, 10/32" KEPS	
8	9.802-759.0	4	SCREW, 10/32" x 1/2" BHSOC BLK	
9	8.752-804.0	1	REGULATOR, 12VOLT DC	
10	8.750-095.0	1	THERMOSTAT, 120C/240F	
11	8.750-097.0	1	KNOB, THERMOSTAT, 120C/240F	
12	8.712-190.0	1	BEZEL, THERMOSTAT	
13	8.718-779.0	2	SCREW, 4 MM X 6 MM	
14	9.802-447.0	48"	CONDUIT, SPLIT	
15	8.756-411.0	1	CONNECTOR, LEVER NUT, 5-WIRES	NOT SHOWN

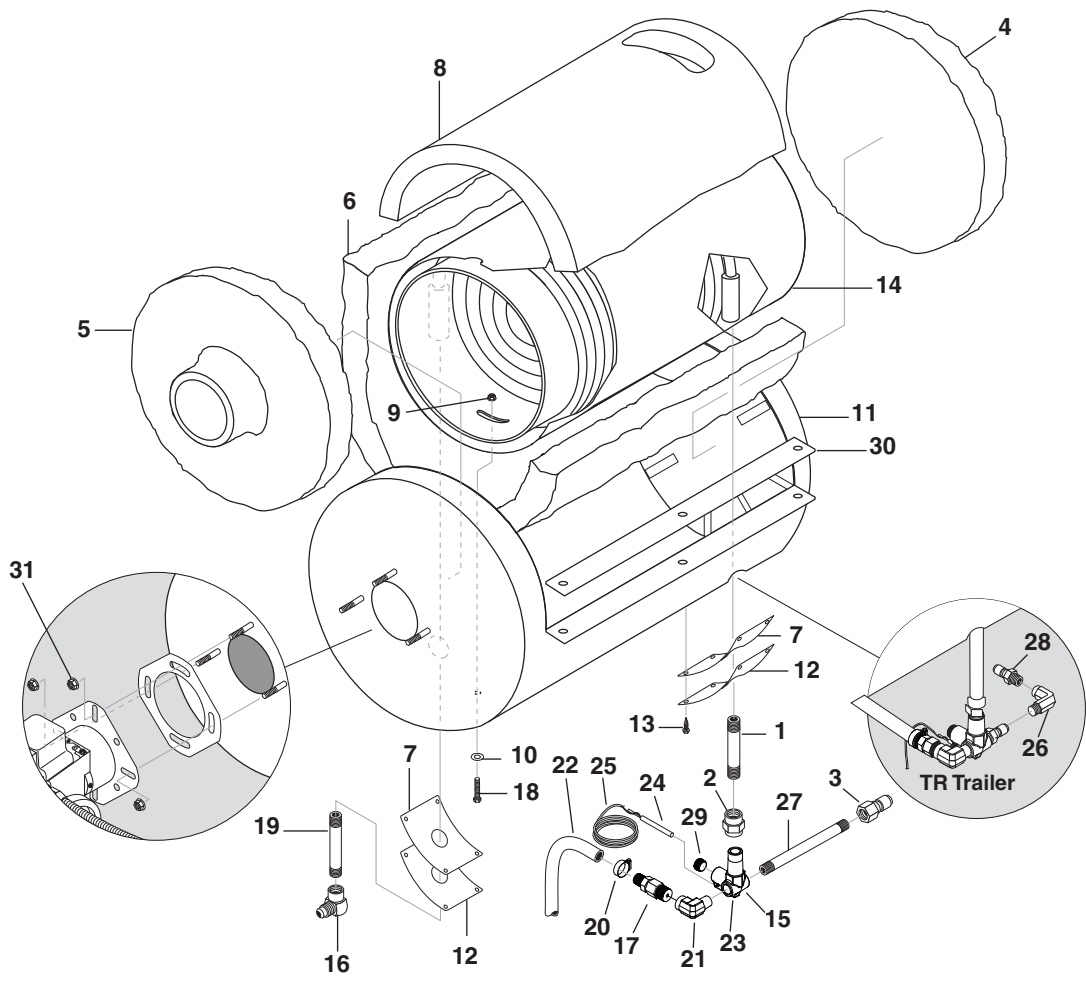

REF	PART NO.	QTY	DESCRIPTION	NOTES
1	8.757-231.0	2	NIPPLE, 1/2" X 3", TAGGED	
2	8.706-141.0	1	COUPLING, 1/2"	
3	9.802-170.0	1	NIPPLE, 3/8" PLUG STEEL/ZINC FEMALE	
4	9.802-883.0	1	INSULATION, FRONT HEAD, NO HOLE	
5	9.802-894.0	1	INSULATION, BURNER HEAD, W/HOLE	
6	9.802-896.0	1	INSULATION, BLANKET, NO FOIL 24" X 57"	
7	8.933-009.0	2	GASKET, BURNER PLATE	
8	9.802-902.0	1	INSUL/BLANKET, DIE CUT 28" X 24" X 1"	
9	9.802-781.0	2	NUT, 3/8" FLANGE WHIZ LOC, NC	
10	9.802-807.0	2	WASHER, FLAT 3/8"	
11	8.916-486.0	1	WLMT, BOTTOM WRAP	
12	9.803-132.0	2	INSULATION RETAINER PLATE	
13	9.802-797.0	8	SCREW, SS #10 X 1/2 HEX HEAD TEK	
14	8.925-216.0	1	SPARE COIL SCH 80W/ALUMNZN STL	
15	8.757-240.0	1	MANIFOLD, COIL OUTLET DISCHARGE, W/TAG	
16	8.757-363.0	1	ELBOW, 90°, 3/4-16 JIC X 1/2 NPTF (F) 90	
17	8.707-381.0	1	RUPTURE DISC ASSY, 8500#	
18	9.802-727.0	2	BOLT, 3/8" X 1-3/4" TAP	
19	8.757-232.0	1	NIPPLE, 1/2" X 4", TAGGED	
20	9.803-559.0	1	CLAMP,SCREW,9/16"W, 1-1/4"OD, SS	
21	8.757-239.0	1	ELBOW, 3/8" MPT X 1/2" FPT ST, W/ TAG	
22	9.802-260.0	26"	HOSE, 1/2" PUSH-ON	
23	9.196-012.0	1	SCREW, 10-24 X 1/4	
24	8.750-095.0	1	THERMOSTAT, 120C/240F, 2 METER CAPILLARY	
25	9.802-447.0	48"	CONDUIT, SPLIT	
26	8.757-340.0	1	ELBOW 3/8", STREET 90 DEG, STEEL, W/SLNT	
27	8.757-230.0	1	NIPPLE, 3/8" X 8", TAGGED	
28	9.802-171.0	1	COUPLER, 3/8" PLUG, MALE STEEL/ZINC	
29	8.757-241.0	1	PLUG, 3/8" ALLEN COUNTER SUNK, W/TAG	
30	8.928-283.0	2	SPACER, COIL WRAP, SS	STAINLESS OPTION ONLY
31	9.802-778.0	3	NUT, 5/16" WHIZ LOC FLANGE	

Option, Float Tank

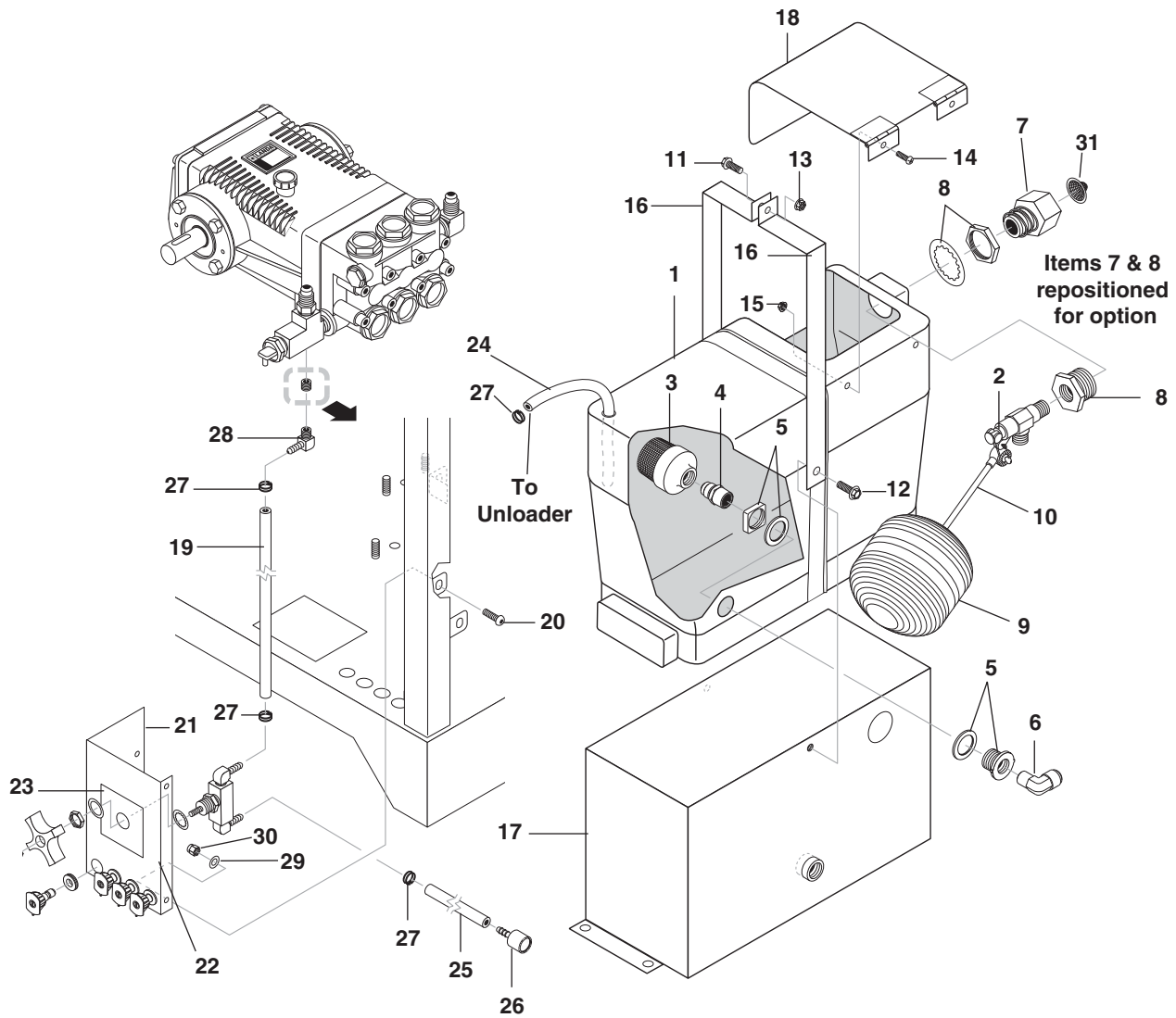

REF	PART NO.	QTY	DESCRIPTION	NOTES
1	9.804-042.0	1	TANK, FLOAT 1-1/2 GAL	
2	8.749-328.0	1	FLOAT VALVE, 1/2" KERICK	
3	8.707-061.0	1	STRAINER, 1/2" BASKET	
4	8.757-200.0	1	ADAPTER, 1/2" 45° SAE x 1/2" MPTF BRASS	
5	8.750-743.0	1	BULKHEAD, 1/2" POLYPRO	
6	8.757-202.0	1	ELBOW, 3/4" 45° SAE X 1/2" M-NPTF, BRASS	
7	8.757-203.0	1	SWIVEL, 1/2" M-NPTF x 3/4" GHF	REPOSITIONED FROM STD BUILD
8	8.707-000.0	1	CONNECTOR, 1/2" ANCHOR	REPOSITIONED FROM STD BUILD
9	8.706-512.0	1	BALL, FLOAT, BLACK PLASTIC	
10	9.803-671.0	1	ROD, THREADED, 1/4" X 5	
11	9.802-768.0	1	SCREW, 3/8" X 1-1/4" WHIZ	
12	9.802-767.0	2	SCREW, 3/8" X 3/4" WHIZ	
13	9.802-781.0	1	NUT, 3/8" FLANGE, WHIZ LOC	
14	9.802-771.0	2	SCREW, 10/32" X 3/4"	
15	9.802-695.0	2	NUT, 10/32" KEPS	
16	8.916-457.0	2	STRAP, FLOAT TANK	
17	8.916-448.0	1	WLMT, BASE, FLOAT TANK	
18	8.916-446.0	1	WLMT, LID, FLOAT TANK	
19	9.802-251.0	18"	TUBE, CLEAR VINYL	
20	9.802-753.0	2	SCREW, 1/4" X 3/4"	
21	8.916-460.0	1	CHEMICAL, FRONT, PGDC	
22	8.902-427.0	1	VALVE, ASSY, CHEMICAL	
23	8.758-419.0	1	LABEL, DETERGENT VALVE PGHW	
24	9.802-252.0	72"	TUBE, BRAIDED VINYL	
25	9.802-251.0	96"	TUBE, CLEAR VINYL	
26	8.707-058.0	1	STRAINER W/CHECK VALVE	
27	6.390-126.0	4	CLAMP	
28	8.757-204.0	1	HOSE BARB, 1/4" BARB X 1/8" M-NPTF, 90°	
29	9.802-802.0	2	WASHER, 1/4" FLAT SAE ZINC	
30	9.802-773.0	2	NUT 1/4-20 ESNA NC	
31	9.804-016.0	1	FILTER SCREEN WASHER, GARDEN HOSE/ 30MESH	

Hose & Spray Gun

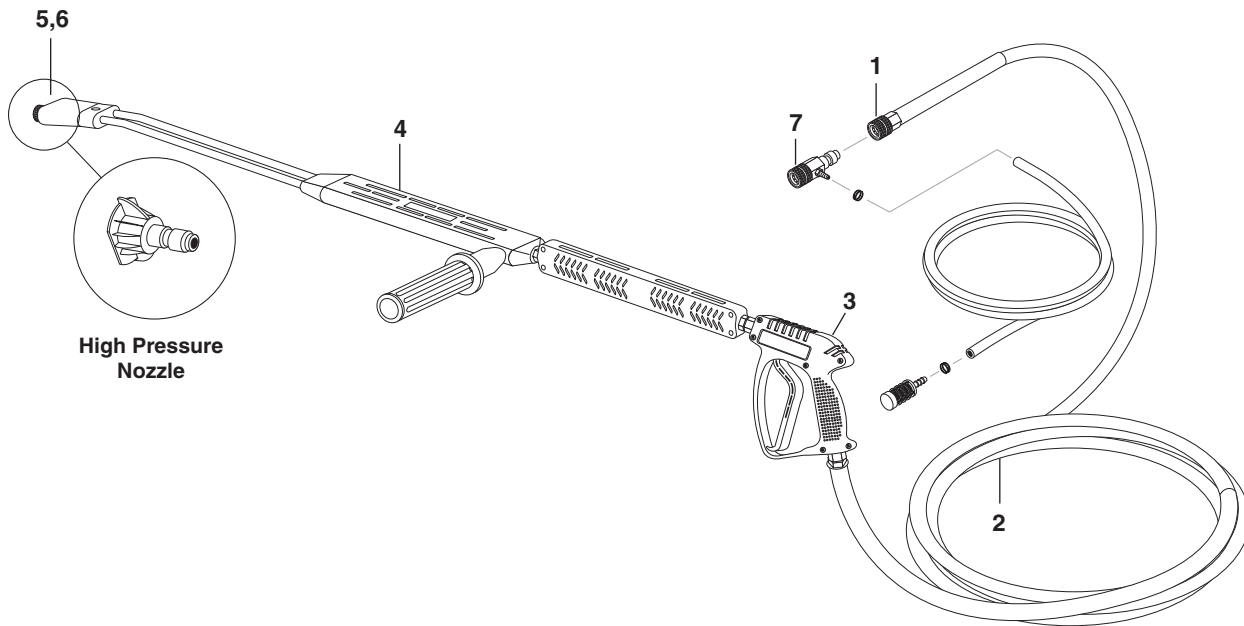

REF	PART NO.	QTY	DESCRIPTION	NOTES
1	9.802-166.0	1	COUPLER, 3/8" FEMALE	
-	9.802-100.0	1	O-RING, 3/8"	REPLACEMENT ONLY NOT SHOWN
2	8.925-132.0	1	HOSE, 3/8" X 50' 2W 6000PSI SW/SO/CPL	PGDC 4-3, PGDC 5-3
-	8.925-244.0	1	HOSE, 1/2"X50' 2W 5000PSI LAN SW,SO,CPL	PGDC 8-3
3	8.751-234.0	1	GUN, LANDA, L1050, 5000 PSI, 10.4 GPM	1.110-072.0
4	8.711-293.0	1	WAND, UP ZNC (AL 344) W/CPLR W/ SOAP NOZZLE	
	83-SSVPKIT	1	REPAIR KIT, AL STAINLESS STEEL	
5	9.802-165.0	1	COUPLER, 1/4" MALE	NOT SHOWN
-	9.802-096.0	1	O-RING	REPLACEMENT ONLY NOT SHOWN
6	9.802-286.0	1	BRASS SOAP NOZZLE	NOT SHOWN
7	8.756-797.0	1	INJECTOR, CHEMICAL, NON ADJ 0.083(2.1MM)	
8	9.802-164.0	1	COUPLER, 1/4"SOCKET, FEMALE, BRASS	NOT SHOWN
9	8.707-139.0	1	COUPLER, 1/4"PLUG, MALE, STEEL/ZINC	NOT SHOWN

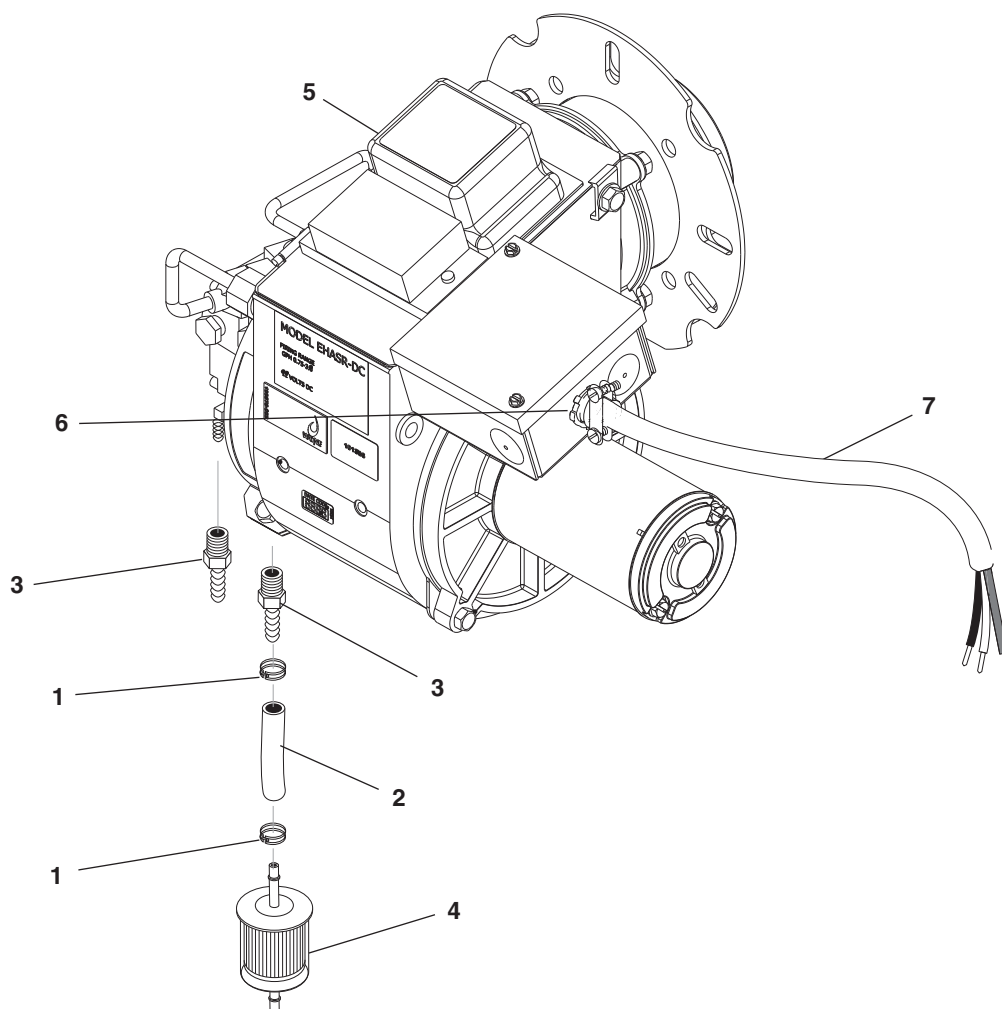

REF	PART NO.	QTY	DESCRIPTION	NOTES
1	8.709-069.0	2	CLAMP, SCREW, 5/16"W, 1/4-5/8" D, SS	
2	9.802-254.0	5"	HOSE, 1/4", PUSH-ON	
3	8.757-199.0	2	HOSE BARB, 1/4" BARB x 1/4" M-NPTF, BRASS	
4	8.709-152.0	1	FILTER, DIESEL FUEL, DISPOSABLE	
5	8.756-480.0	1	BURNER, EHASR 12VDC DO 2T 12VDC S	
6	9.802-519.0	1	STRAIN RELIEF, 2 SCREW 2 METAL 1/2"	
7	9.802-428.0	30"	CORD, SERVICE, SJOWA 12/3	
8	8.756-697.0	1	FUEL NOZZLE, 2.50 X 80 B W/ 100 PSI CHECK VALVE	1.110-050.0, 1.110-051.0, 1.110-072.0
-	8.755-610.0	1	FUEL NOZZLE, 1.75 X 80A W/ 100 PSI CHECK VALVE	1.110-049.0
-	8.756-409.0	-	CONNECTOR, LEVER NUT, 2-WIRES	REPLACEMENT ONLY
-	8.756-410.0	-	CONNECTOR, LEVER NUT, 3-WIRES	REPLACEMENT ONLY
-	8.756-411.0	-	CONNECTOR, LEVER NUT, 5-WIRES	REPLACEMENT ONLY

Unloader - 4-3500, 5-3500

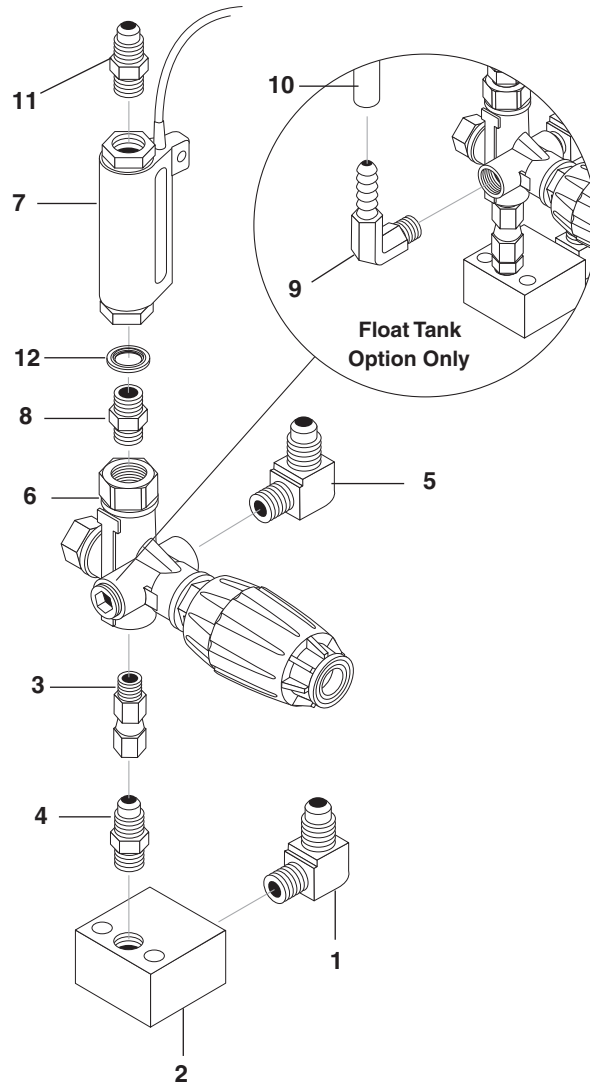

REF	PART NO.	QTY	DESCRIPTION	NOTES
1	8.757-509.0	1	ELBOW, 3/4"-16 SAE X 3/8" NPTF(M), STEEL	
2	9.802-870.0	1	BLOCK, UNLOADER, 3/8 X 3/8, 1.25 BRASS	
3	8.757-656.0	1	ADAPTER SWIVEL STEEL 1/2 JICX3/8 NPTF(M)	
4	8.757-655.0	1	ADAPTER STEEL 1/2" JIC X 3/8" NPTF(M)	
5	8.757-262.0	1	ELBOW, 1/2" SAE 45° X 3/8" NPTF(M) BRASS	
6	8.750-299.0	1	UNLOADER VRT 3, 8 GPM @ 4500 PSI	
7	8.933-006.0	1	SWITCH, FLOW MV60	
8	8.757-653.0	1	NIPPLE STEEL HEX 3/8" NPTF X 3/8" BSPP	
9	8.757-644.0	1	HOSE BARB BRASS 1/4 X 3/8 NPTF (M) 90°	FLOAT TANK OPTION
10	9.802-252.0	6'	HOSE, 1/4" x 1/2", BRAIDED VINYL, /FT	FLOAT TANK OPTION
11	8.756-875.0	1	ADAPTER, 3/4-16 M JIC X G 3/8-19 M	
12	8.757-211.0	1	SEAL, BONDED, BSPP, 3/8" (-06)	

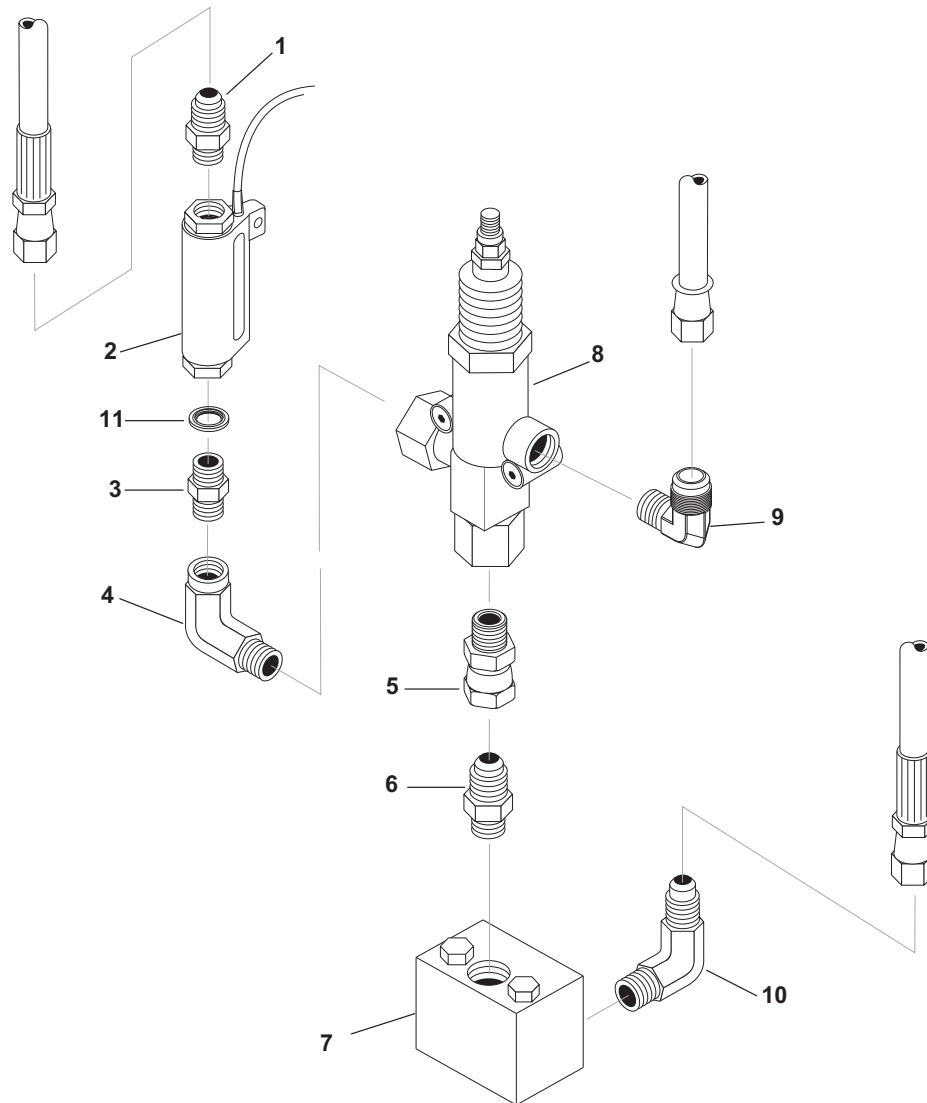

REF	PART NO.	QTY	DESCRIPTION	NOTES
1	8.756-875.0	1	ADAPTER, 3/4-16 M JIC X G 3/8-19 M	
2	8.933-006.0	1	SWITCH, FLOW MV60	
3	8.757-653.0	1	NIPPLE STEEL HEX 3/8" NPTF X 3/8" BSPP	
4	8.757-654.0	1	ELBOW STREET STEEL NPTF 1/2 (M)X3/8 (F)	
5	8.757-624.0	1	SWIVEL 1/2 JIC (F) X 1/2 NPTF (M)	
6	8.757-508.0	1	ADAPTER, 3/4"-16SAE X 1/2" NPTF(M),STEEL	
7	9.802-869.0	1	BLOCK, UNLOADER, 1/2 X 1/2, 1.75, STEEL	
8	8.712-708.0	1	UNLOADER VALVE (GIANT 22913) 30	
9	8.757-202.0	1	ELBOW, 3/4" 45° SAE X 1/2" M-NPTF,BRASS	
10	8.757-510.0	1	ELBOW, 3/4"-16 SAE, 1/2"NPTF (M), STEEL	
11	8.757-211.0	1	SEAL, BONDED, BSPP, 3/8" (-06)	

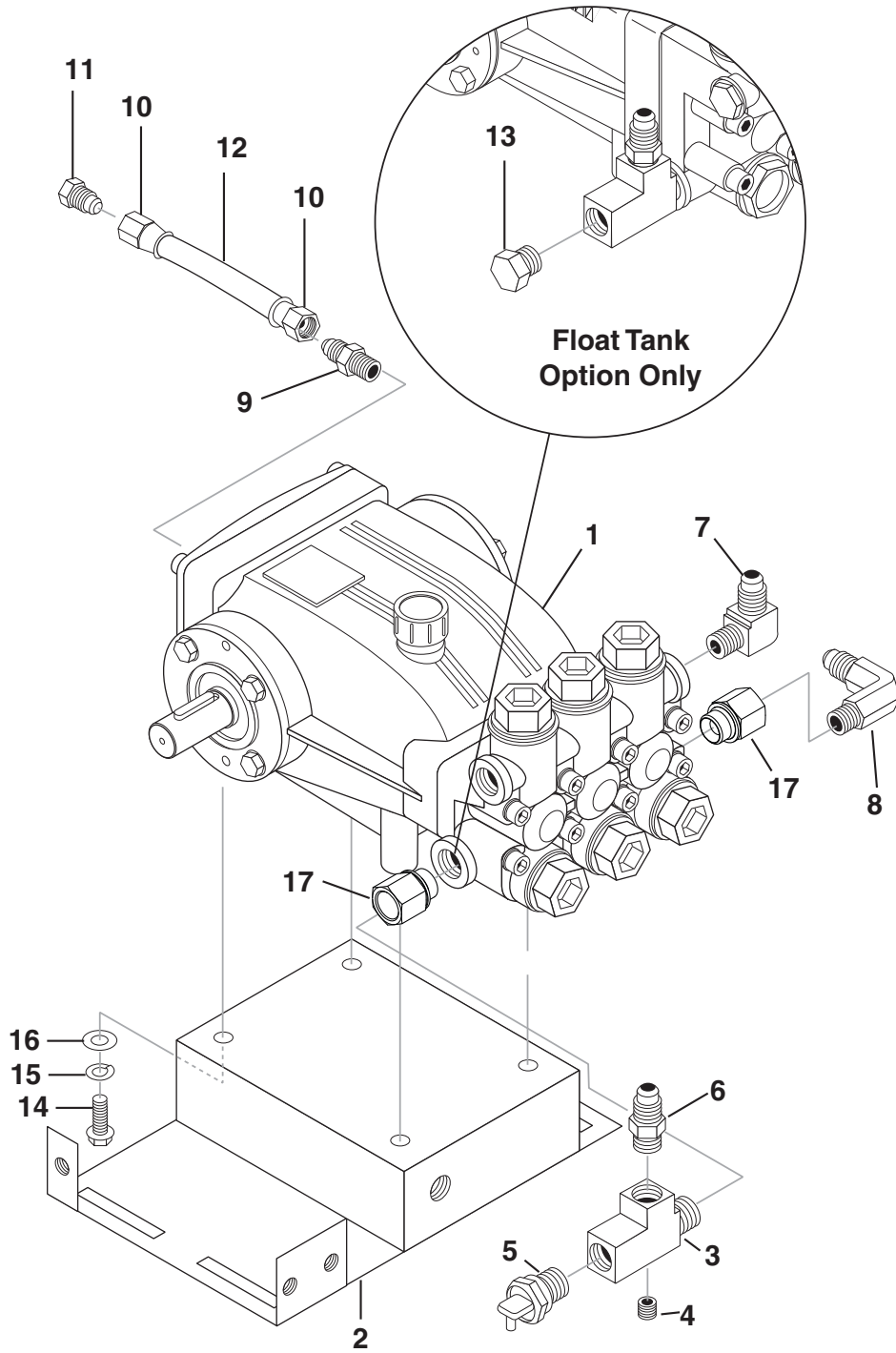

REF	PART NO.	QTY	DESCRIPTION	NOTES
1	8.921-713.0	1	PUMP, LT6036L	(1.110-051.0 1.110-050.0)
-	8.921-711.0	1	PUMP, LT4540L	(1.110-049.0)
-	8.920-590.0	1	PUMP, LANDA LX9536L.2, 9.5@3625 1740RPM	(1.110-072.0)
2	8.912-461.0	1	ASSY, GAS PUMP PLATE	
3	8.757-224.0	1	TEE, STREET 1/2" W/HOLE TAP	
4	8.757-660.0	1	PLUG COUNTER SUNK BRASS 1/8	
5	8.707-256.0	1	PUMP PROTECTOR, 1/2"	
6	8.757-200.0	1	ADAPTER, 1/2" 45° SAE X 1/2" M-NPTF BRAS	
-	8.757-194.0	1	ADAPTER, 3/4" 45° SAE X 1/2" M-NPTF, BRASS	(1.110-072.0)
7	8.757-616.0	1	ADAPTER 1/2 JIC (M) X 3/8 BSPP (M) 90°	
-	8.757-617.0	1	ADAPTER 1/2 JIC (M) X 1/2 BSPP (M) 90°	(1.110-072.0)
8	8.757-202.0	1	ELBOW, 3/4" 45° SAE X 1/2" M-NPTF, BRASS	
9	8.758-007.0	1	ADAPTER BRASS 1/2 JIC (M) X 3/8 NPTF (M)	
10	9.802-151.0	2	SWIVEL 1/2" PUSH-ON	
11	9.802-126.0	1	PLUG, 1/2" JIC	
12	9.802-259.0	20"	HOSE, 1/2" PUSH-ON	
13	8.757-657.0	1	PLUG HEX BRASS 1/2" NPTF (M)	FLOAT TANK OPTION
14	9.802-744.0	4	BOLT, 10MM X 20MM, ZINC	
15	8.718-961.0	4	WASHER, M10, SPLIT ZINC	
16	9.802-807.0	4	WASHER 3/8" FLAT ZINC	
17	8.756-874.0	2	ADAPTER, G 1/2-14 X 1/2-14 NPTF	
-	8.757-626.0	2	ADAPTER 3/4 BSPP (M) X 1/2 NPTF (F)	(1.110-072.0)

Specifications

Pump

Machine Model	Pump Model	Part #	Pulley	Pulley Part #	Bushing	Bushing Part #	Belt Size/Qty	Belt Part #
1.110-049.0	LT4540/L	8.921-711.0	2BK90	8.715-593.0	25mm	9.802-403.0	BX36 (2)	8.715-697.0
1.110-050.0	LT6036/L	8.921-713.0	2BK90	8.715-593.0	25mm	9.802-403.0	BX36 (2)	8.715-697.0
1.110-051.0	LT6036/L	8.921-713.0	2BK90	8.715-593.0	25mm	9.802-403.0	BX36 (2)	8.715-697.0
1.110-072.0	LX9536/L	8.920-590.0	2BK80	8.715-592.0	25mm	9.802-403.0	BX35 (2)	9.802-415.0
1.110-096.0	LT6036/L	8.921-713.0	2BK90	8.715-593.0	25mm	9.802-403.0	BX36 (2)	8.715-697.0
1.110-098.0	LX9536/L	8.920-590.0	2BK80	8.715-592.0	25mm	9.802-403.0	BX35 (2)	9.802-415.0

Engine

Model	Model	Part #	Pulley	Pulley Part #	Bushing	Bushing Part #
1.110-049.0	Honda GX390(389cc)	8.759-122.0	2BK32H	8.715-576.0	Hx1"	9.802-399.0
1.110-050.0	Briggs Vanguard(570cc)	8.754-819.0	2BK32H	8.715-576.0	Hx1"	9.802-399.0
1.110-051.0	Honda GX630(688cc)	8.752-149.0	2BK32H	8.715-576.0	Hx1"	9.802-399.0
1.110-072.0	Honda GX690 (688cc)	8.757-350.0	2BK36H	9.802-383.0	Hx1-1/8"	9.802-400.0
1.110-096.0	Loncin 25hp	8.759-746.0	2BK32H	8.715-576.0	Hx1-1/8"	9.802-400.0
1.110-098.0	Loncin 25hp	8.759-746.0	2BK36H	9.802-383.0	Hx1-1/8"	9.802-400.0

PGDC Series Wayne "EHASR-DC" Burner

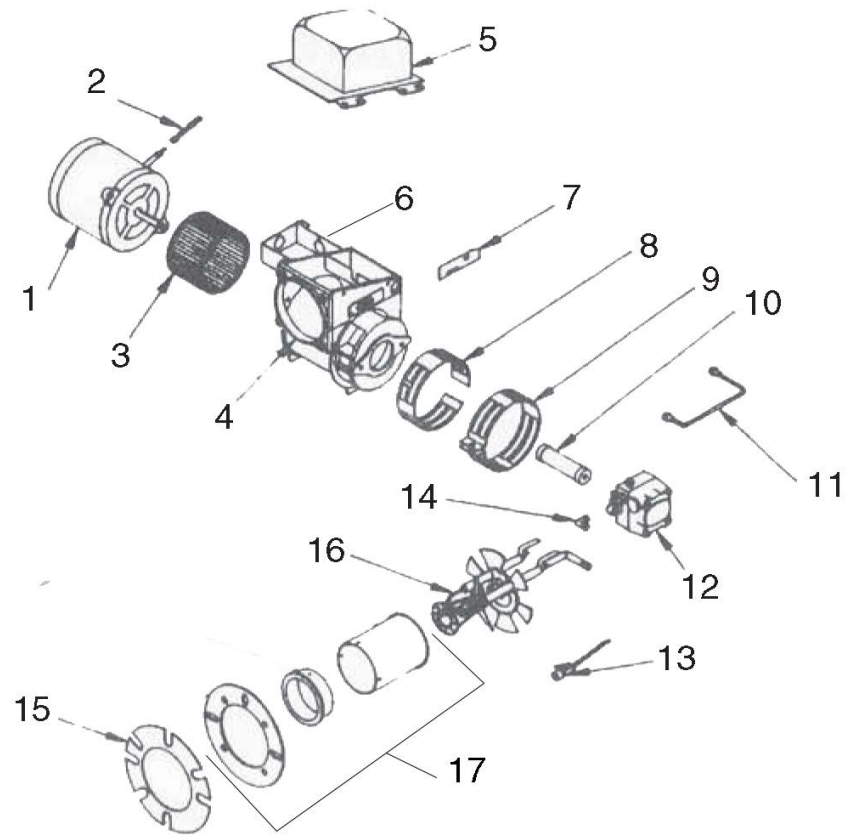

REF	PART NO.	QTY	DESCRIPTION	NOTES
1	8.756-716.0	1	MOTOR, 1/4 13.5VDC AMETEK	
2	13121	1	MOTOR CORD COVER	
3	8.756-726.0	1	FAN, 3.44"W X 5.25"D 5/16" BORE	
4	8.700-735.0	1	BURNER HOUSING EHASR	
5	9.107-507.0	1	IGNITOR, 12VDC, LOW AMP	
6	8.756-741.0	1	JUNCTION BOX, EHASR, BLACK COVER	NOT SHOWN
-	8.756-742.0	1	JUNCTION BOX, EHASR, BLACK BODY	
-	8.756-743.0	3	PLUG, HOLE, JUNCTION BOX, M&E	NOT SHOWN
7	13392	1	SLOT COVER PLATE	
8	8.700-732.0	1	BAND, AIR BURNER INNER EHA/SR	
9	8.700-729.0	1	AIR BAND 8 HOLE OUTER EHA/SR	
10	8.700-715.0	1	COUPLING, "E" DC	
11	8.700-704.0	1	OIL LINE, 6'	
12	8.756-437.0	1	PUMP - COMBO 12V/24V	
13	8.700-819.0	1	CAD CELL	
-	8.756-661.0	1	TIMER, DROP-OUT	NOT SHOWN
14	13494	1	BRASS 90° ELBOW	
15	8.700-692.0	2	GASKET	
16	8.756-299.0	1	GUN ASSEMBLY, BURNER-RG/*CST/GBB	
17	8.756-305.0	1	FLANGE, AIR TUBE, WELDED 1.75" "E"	(ALL PGWH'S)
-	8.700-724.0	1	AIR CONE 4A	
18	8.757-835.0	1	KIT, IGNITOR/TIMER/CAD CELL W/ PLATE REPLACEMENT	(ITEMS 5, 13 & PLATE)
19	8.700-770.0	1	KIT, ELECTRODE ASSY REPLACEMENT	(PART OF ITEM 16)

G3 Evolution

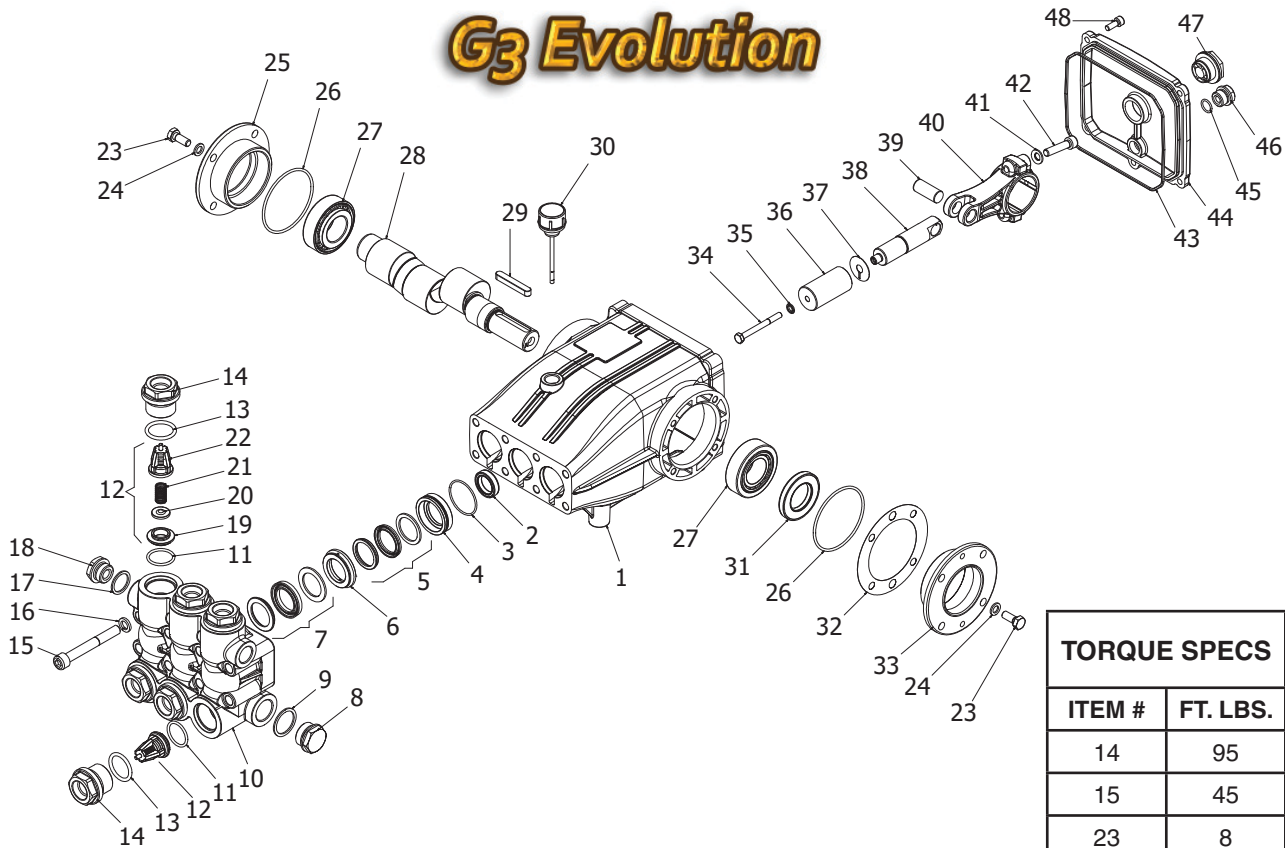

TORQUE SPECS	
ITEM #	FT. LBS.
14	95
15	45
23	8
34	10
42	30
48	8

REF	PART NO.	QTY	DESCRIPTION	NOTES
1	8.752-825.0	1	CRANKCASE	
2	-	3	PLUNGER OIL SEAL	SEE KITS TABLE
3	-	3	O-RING Ø1.78 X 37.82	SEE KITS TABLE
4	-	3	PRESSURE RING, 18MM	SEE KITS TABLE
5	-	3	U-SEAL, 18MM	SEE KITS TABLE
6	-	3	INTERMEDIATE RING, 18MM	SEE KITS TABLE
7	-	3	U-SEAL, 18MM	SEE KITS TABLE
8	9.802-926.0	1	BRASS PLUG, G1/2	
9	9.803-199.0	1	COPPER WASHER 1/2	
10	8.753-816.0	1	MANIFOLD HOUSING	
11	9.804-498.0	6	O-RING Ø2.62 X 25.1	SEE KITS TABLE
12	-	6	VALVE ASSEMBLY	SEE KITS TABLE
13	9.803-193.0	6	O-RING 3068	SEE KITS TABLE
14	9.802-928.0	6	VALVE PLUG	
15	8.753-817.0	8	MANIFOLD STUD BOLT	
16	9.802-890.0	8	LOCK WASHER	

REF	PART NO.	QTY	DESCRIPTION	NOTES
17	8.719-008.0	1	COPPER WASHER 3/8	
18	8.707-262.0	1	BRASS PLUG 3/8	
19	-	6	VALVE SEAT	SEE KITS TABLE
20	-	6	VALVE PLATE	SEE KITS TABLE
21	-	6	VALVE SPRING	SEE KITS TABLE
22	-	6	VALVE CAGE	SEE KITS TABLE
23	8.752-830.0	8	HEX SCREW	
24	9.802-884.0	8	WASHER	
25	9.803-182.0	1	CLOSED BEARING HOUSING	
26	9.803-186.0	2	O-RING Ø2.62 X 71.12	
27	9.803-160.0	2	ROLLER BEARING	
28	8.753-818.0	1	CRANKSHAFT Ø25 (4540)	
-	8.752-827.0	1	CRANKSHAFT Ø25 (6036)	
29	9.803-167.0	1	CRANKSHAFT KEY	
30	8.752-834.0	1	OIL DIP STICK	
31	9.803-139.0	1	CRANKSHAFT SEAL	
32	9.803-177.0	2	SHIM	
33	9.803-181.0	1	BEARING HOUSING	
34	8.752-841.0	3	PLUNGER BOLT	SEE KITS TABLE
35	8.752-820.0	3	BONDED SEAL	SEE KITS TABLE
36	8.753-819.0	3	PLUNGER, 18MM	SEE KITS TABLE
37	8.752-823.0	3	COPPER SPACER	SEE KITS TABLE
38	8.753-820.0	3	PLUNGER ROD	
39	8.752-822.0	3	CONNECTING ROD PIN	
40	8.752-821.0	3	CONNECTING ROD	
41	9.802-889.0	6	SPRING WASHER	
42	9.802-937.0	6	CONNECTING ROD SCREW	
43	9.803-194.0	1	O-RING Ø2.62 X 152.07	
44	8.752-826.0	1	CRANKCASE COVER	
45	9.803-906.0	1	O-RING Ø1.78 X 14.00	
46	8.707-262.0	1	BRASS PLUG G3/8	
47	9.803-202.0	1	SIGHT GLASS G3/4	
48	8.752-824.0	5	COVER SCREW	

KIT NUMBERS	8.753-821.0	8.758-061.0	8.753-823.0	8.753-824.0	8.752-835.0
KIT DESCRIPTION	Plunger Seals 18 mm	Seal Packing 18 mm	Plunger 18 mm	Complete Valve	Plunger Oil Seals
ITEMS NUMBERS INCLUDED	3, 5, 7	3, 4, 5, 6, 7,	34, 35, 36, 37	11, 12, 13	2
NO. OF CYLINDERS KIT WILL SERVICE	3	3	1	6	3

VRT3 Unloader

8.750-297.0, 8 GPM, 2320 PSI

8.750-298.0, 8 GPM, 3630 PSI

8.750-299.0, 8 GPM, 4500 PSI

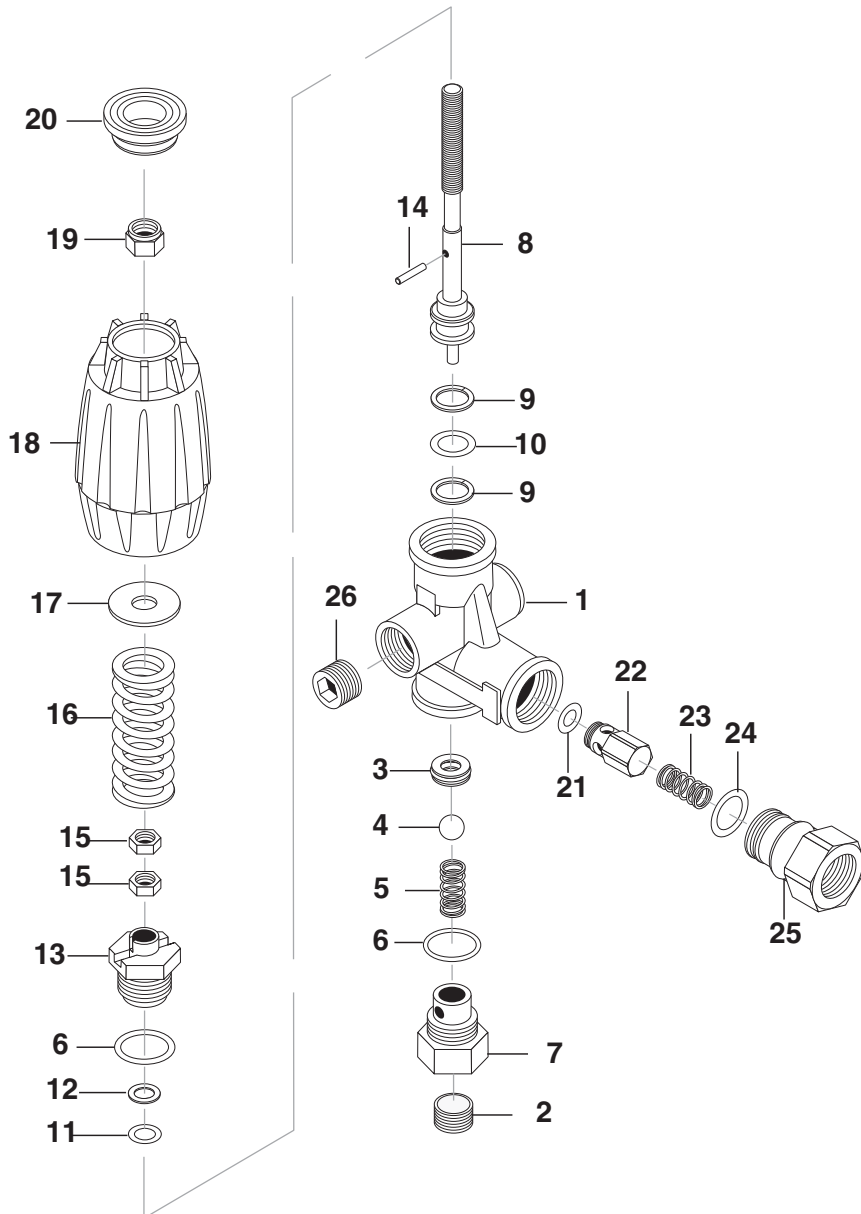

REF	PART NO.	QTY	DESCRIPTION	NOTES
25	8.750-713.0	1	OUTLET FITTING	
18	8.750-712.0	1	KNOB, UNLOADER	
-	8.750-709.0	-	REPAIR KIT, VRT3, 2320/3630 PSI	
-	8.750-710.0	-	REPAIR KIT, VRT3, 4500 PSI	
-	-	-	(KIT ITEMS: 3, 4, 6, 9-12, 21, 24)	

Unloader Adjustment Procedures

1. Remove lock nut (Item 19).
2. Remove adjustment knob (Item 18).
3. Loosen the two (2) nuts (Item 15), move them upward on stem (Item 8) until you see 4 or more threads below the nut.
4. Re-attach adjusting knob (Item 18).
5. Start machine. Open the trigger of the spray gun. Increase pressure by turning adjustment knob (Item 18) clockwise until pressure is at the desired operating pressure.
6. Remove the adjustment knob (Item 18), tighten the lower nut (Item 15) tightly against the upper nut (Item 15). Re-attach adjustment knob (Item 18) and screw down until contact is made with the nuts (Items 15). Screw down lock nut (Item 19) onto the stem (Item 8) until the threads cut into the nylon insert of the lock nut (Item 19).

*If adjustment knob (Item 18) **DOES NOT** make contact with upper nut (Items 15), remove adjusting knob (Item 18), re-adjust (raise) nuts (Items 15) on stem (Item 8) and re-attach adjustment knob (Item 18), then repeat step #6.

If adjustment knob (Item 18) **DOES make contact with upper nut; release the trigger of the spray gun and watch the pressure gauge for the pressure increase (“spike”). This “spike” **SHOULD NOT** exceed 500 psi above the operating pressure. If “spike” pressure exceeds the 500 psi limit, remove the adjusting knob (Item 18) and re-adjust (lower) the nuts (Items 15) on the stem (Item 8). Re-attach the adjusting knob (Item 18), then repeat step #6.

LANDA[®]

8.916-596.0 • Printed in U.S.A.