

HOT Series

Hot Water - Electric Powered - Diesel/Oil Heated

LANDA®

Operator's Manual

Pressure Washer



MODELS:	HOT 2-11024D 1.109-095.0
	HOT 2-15024D 1.109-096.0
	HOT 2-11026D 1.109-093.0
	HOT 2-15026D 1.109-094.0
	HOT 3-11024D 1.109-097.0
	HOT 3-30036D 1.109-100.0
	HOT 4-20024A 1.109-098.0
	HOT 4-20024G 1.109-99.0

For the Landa Dealer nearest you, consult our web page at www.landa.com

SHOP PRESSURE WASHER PARTS

shoppressurewasherparts.com | (888) 269-0172



8.917-208.0-B 01/07/20

Machine Data Label

Model: _____

Date of Purchase: _____

Serial Number: _____

Dealer: _____

Address: _____

Phone Number: _____

Sales Representative: _____

Machine Data Label 2
Table of Contents 3
How To Use This Manual 4

Safety

Important Safety Information. 5

Operations

Component Identification 8
Installation 9
Location: 9
Electrical 9
Placement 9
Connection 9
Assembly & Operation Instructions 10
Assembly & Operation Instructions 11
Insulated Straight Wand Assembly 12
Variable Pressure Wand Assembly 12
Steam Wand Assembly 12
Detergents & General Cleaning Techniques 13
Thermal Pump Protection 13
Cleaning Tips 13
Rinsing 13
Shutting Down & Clean-up 14
Storage 14
Engine Maintenance 14

Maintenance

Preventative Maintenance 15
Unloader Valves 15
Winterizing Procedure 15
High Limit Hot Water Thermostat 15
Pumps 15
Cleaning of Coils 15
Rupture Disk 16
Fuel 16
Electrode Setting: Wayne 16
Electrode Setting: Beckett 16
Burner Nozzle 16
Fuel Control System 16
Fuel Pressure Adjustment 17
Air Adjustment 17
Removal of Soot and Heating Coil 17
Coil Reinstallation 17
Preventative Maintenance 18
Maintenance Schedule 18
Oil Change Record 18
Troubleshooting 19

How To Use This Manual

This manual contains the following sections:

- How to Use This Manual
- Safety
- Operations
- Maintenance

The HOW TO USE THIS MANUAL section will tell you how to find important information for ordering correct repair parts.

Parts may be ordered from authorized dealers. When placing an order for parts, the machine model and machine serial number are important. Refer to the MACHINE DATA box which is filled out during the installation of your machine. The MACHINE DATA box is located on the inside of the front cover of this manual.

Model:	_____
Date of Purchase:	_____
Serial Number:	_____
Dealer:	_____
Address:	_____
Phone Number:	_____
Sales Representative:	_____

The model and serial numbers will be found on a decal attached to the pressure washer.

Thank you for purchasing this Pressure Washer.

We reserve the right to make changes at any time without incurring any obligation.

Owner/User Responsibility:

The owner and/or user must have an understanding of the manufacturer's operating instructions and warnings before using this pressure washer. Warning information should be emphasized and understood. If the operator is not fluent in English, the manufacturer's instructions and warnings shall be read to and discussed with the operator in the operator's native language by the purchaser/owner, making sure that the operator comprehends its contents.

Owner and/or user must study and maintain for future reference the manufacturers' instructions.

The operator must know how to stop the machine quickly and understand the operation of all controls. Never permit anyone to operate the engine without proper instructions.

This manual should be considered a permanent part of the machine and should remain with it if machine is resold.

When ordering parts, please specify model and serial number. Use only identical replacement parts.

This machine is to be used only by trained operators.

Important Safety Information



WARNING: To reduce the risk of injury, read operating instructions carefully before using.

AVERTISSEMENT: Pour réduire le risque de blessures, lire attentivement les instructions de fonctionnement avant l'utilisation.

1. Read the owner's manual thoroughly. Failure to follow instructions could cause malfunction of the machine and result in death, serious bodily injury and/or property damage.
2. Know how to stop the machine and bleed pressure quickly. Be thoroughly familiar with the controls.
3. Stay alert — watch what you are doing.

4. All installations must comply with local codes. Contact your electrician, plumber, utility company or the selling dealer for specific details. If your machine is rated 250 volts or less, single phase with a ground fault circuit interrupter (GFCI) will be provided. If rated more than 250 volts, or more than single phase this product should only be connected to a power supply protected by a GFCI.

WARNING: Must be plugged into properly wired three hole grounded outlet that accommodates plug on power cord. Failure to comply could result in electric shock.

AVERTISSEMENT: Doit être raccordé dans une sortie à trois trous mise à la masse et correctement câblée qui peut accueillir une fiche sur un cordon d'alimentation Le non-respect de cette consigne pourrait causer un choc électrique.

DANGER: Improper connection of the equipment grounding conductor can result in a risk of electrocution. Check with a qualified electrician or service personnel if you are in doubt as to whether the outlet is properly grounded. Do not modify the plug provided with the product - if it will not fit the outlet, have a proper outlet installed by a qualified electrician. Do not use any type of adapter with this product

DANGER: Une mauvaise connexion du conducteur de terre de l'équipement peut entraîner un risque d'électrocution. Vérifier auprès d'un électricien qualifié ou du personnel d'entretien si vous avez des doutes quant à savoir si la sortie est correctement mise à la masse. Ne pas modifier la fiche fournie avec le produit - si elle n'entre pas dans la sortie, faire installer une sortie appropriée par un électricien qualifié. Ne jamais utiliser un adaptateur avec ce produit.



WARNING: Keep wand, hose, and water spray away from electric wiring or fatal electric shock may result.

AVERTISSEMENT: Garder la lance, le boyau et le jet d'eau à l'écart de tout câblage électrique ou des chocs électriques mortels pourraient survenir.

- To protect the operator from electrical shock, the machine must be electrically grounded. It is the responsibility of the owner to connect this machine to a UL grounded receptacle of proper voltage and amperage ratings. Do not spray water on or near electrical components. Do not touch machine with wet hands or while standing in water. Always disconnect power before servicing.



WARNING: Flammable liquids can create fumes which can ignite, causing property damage or severe injury.

AVERTISSEMENT: Des liquides inflammables peuvent produire des vapeurs qui peuvent s'enflammer, causant ainsi des dommages à la propriété ou des blessures graves.

WARNING: Risk of explosion — Operate only where open flame or torch is permitted.

AVERTISSEMENT: Risque d'explosion- Utiliser uniquement dans des endroits où l'utilisation d'une flamme nue ou d'une torche est permise.

- In oil burning models, use only kerosene, No. 1 home heating fuel, or diesel. If diesel is used, add a soot remover to every tankful.



WARNING: Risk of fire — Do not add fuel when the product is operating or still hot.

AVERTISSEMENT: Risque d'incendie- Ne pas ajouter de carburant pendant que la machine fonctionne ou est encore chaude.

WARNING: Do not use gasoline crankcase drainings or oil containing gasoline, solvents or alcohol. Doing so will result in fire and/or explosion.

AVERTISSEMENT: Ne pas utiliser d'essence, de drainage du carter de moteur ou d'essence contenant de l'huile, de solvants ou de l'alcool.

- This pressure washer shall be installed only in locations where combustible dusts and flammable

gases or vapors are not present. Do not store or use gasoline near this machine.

- Do not allow acids, caustic or abrasive fluids to pass through the pump.
- Never run pump dry or leave spray gun closed longer than 1-2 minutes.
- Keep operating area clear of all persons and animals.



WARNING: High pressure spray can cause paint chips or other particles to become airborne and fly at high speeds. To avoid personal injury, eye, face, hand and foot safety devices must be worn.

AVERTISSEMENT: Un jet haute pression peut écailler la peinture ou provoquer l'émission d'autres particules dans l'air et leur projection à hautes vitesses. Pour éviter les lésions corporelles, une protection des yeux, du visage, des mains et des pieds doit être portée lors de l'utilisation de cet équipement.

- Always wear properly rated eye protection such as safety goggles or face shield while spraying. (Safety glasses do not provide full protection.)



WARNING: Hot discharge fluid. Do not touch or direct discharge stream at persons or animals or severe injury or death will result.

AVERTISSEMENT: Liquide de décharge chaud. Ne pas toucher ou décharger directement le jet vers des personnes ou des animaux, car cela risquerait de causer des blessures graves ou même la mort.

WARNING: This machine produces hot water and must have insulated components attached to protect the operator.

AVERTISSEMENT: Cette machine produit de l'eau chaude et doit comporter des composants isolés attachés pour protéger l'opérateur.



WARNING: Risk of injury. Hot surfaces can cause burns. Use only designated gripping areas of spray gun and wand. Do not place hands or feet on non-insulated areas of the pressure washer.

AVERTISSEMENT: Risque de blessures. Les surfaces chaudes peuvent causer des brûlures. Utiliser uniquement les zones de

prise désignées du pistolet pulvérisateur et de la lance. Ne pas placer les mains ou les pieds sur des endroits non isolés de la laveuse à pression.

12. To reduce the risk of injury, close supervision is necessary when a machine is used near children. Do not allow children to operate the pressure washer. This machine must be attended during operation.



WARNING: Grip cleaning wand securely with both hands before starting. Failure to do this could result in injury from a whipping wand.

AVERTISSEMENT: Agripper la lance de nettoyage avec les deux mains avant de commencer. Le non-respect de cette consigne pourrait mener à des blessures causées par le mouvement violent de la lance.

13. Never make adjustments on machine while in operation.

14. Be certain all quick coupler fittings are secured before using pressure washer.



WARNING: High pressure developed by these machines will cause personal injury or equipment damage. Keep clear of nozzle. Use caution when operating. Do not direct discharge stream at people or animals, or severe injury or death will result.

AVERTISSEMENT: La haute pression générée par ces machines causera des lésions corporelles ou des dommages à l'équipement. Se tenir à l'écart de la buse. Faire preuve de prudence lors de l'utilisation. Ne pas décharger directement le jet vers des personnes ou des animaux, car cela risquerait de causer des blessures graves ou même la mort.



WARNING: Protect machine from freezing.

AVERTISSEMENT: Protéger la machine contre le gel.

15. To keep machine in best operating conditions, it is important you protect machine from freezing. Failure to protect machine from freezing could cause malfunction of the machine and result in

death, serious bodily injury, and/or property damage. Follow storage instructions specified in this manual.

16. Inlet water must be clean fresh water and no hotter than 90°F.



WARNING: Risk of asphyxiation. Use this product only in a well ventilated area.

AVERTISSEMENT: Risque d'asphyxie. Utiliser ce produit uniquement dans un endroit bien ventilé.

17. Avoid installing machines in small areas or near exhaust fans.

Adequate oxygen is needed for combustion or dangerous carbon monoxide will result.

18. Manufacturer will not be liable for any changes made to our standard machines or any components not purchased from us.
19. The best insurance against an accident is precaution and knowledge of the machine.



WARNING: Be extremely careful when using a ladder, scaffolding or any other relatively unstable location. The cleaning area should have adequate slopes and drainage to reduce the possibility of a fall due to slippery surfaces.

AVERTISSEMENT: Faire preuve d'une extrême prudence au moment d'utiliser une échelle, des échafaudages ou toute autre surface relativement instable. La zone de nettoyage doit avoir une pente et un drainage adéquats pour réduire la possibilité d'une chute due à une surface glissante.

20. Do not overreach or stand on unstable support. Keep good footing and balance at all times.

21. Do not operate this machine when fatigued or under the influence of alcohol, prescription medications, or drugs.



WARNING: Do not spray machine or any people, animals or electrical parts.

AVERTISSEMENT: Ne pas vaporiser sur la machine ou les gens, les animaux ou les pièces électriques



Follow the maintenance instructions specified in the manual.

Operations

Component Identification

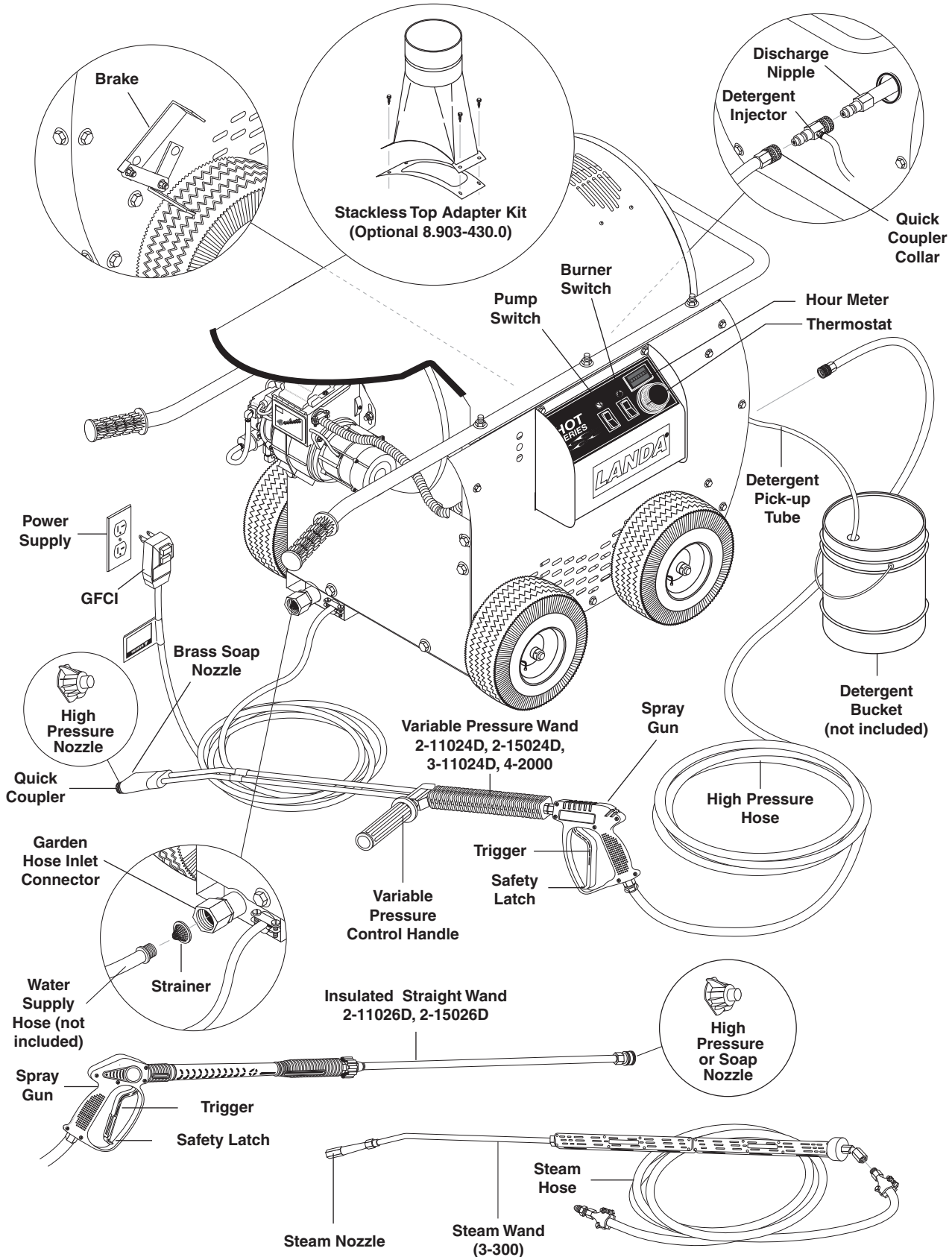

Installation

Place machine in a convenient location providing ample support, drainage and room for maintenance.

These machines are designed for indoor use. They must be stored indoors when not in use.

Location:

The location should protect the machine from damaging environmental conditions, such as wind, rain, and freezing temperatures.

The machine should be run on a level surface where it is not readily influenced by outside sources such as strong winds, freezing temperatures, rain, etc. The machine should be located to allow accessibility for refilling of fuel, adjustments and maintenance. Normal precautions should be taken by the operator of the machine to prevent excess moisture from reaching the power unit or electrical controls.

It is recommended that a partition be made between the wash area and the machine to prevent direct water spray from coming in contact with the machine. Excess moisture reaching any electrical components or controls will reduce machine life and may cause electrical shorts.

During installation of the machine, beware of poorly ventilated locations or areas where exhaust fans may cause an insufficient supply of oxygen. Sufficient combustion can only be obtained when there is a sufficient supply of oxygen available for the amount of fuel being burned. If it is necessary to install a machine in a poorly ventilated area, outside fresh air may have to be piped to the burner and a fan installed bringing the air into the machine.

WARNING: Avoid small areas or areas near exhaust fans.

AVERTISSEMENT: Éviter les petites superficies ou les surfaces à proximité des ventilateurs d'extraction.

Electrical

The machine, when installed, must be electrically grounded in accordance to local codes. Check for proper power supply using a volt meter. The HOT 2-1100, HOT 2-1500, and HOT 3-1100 each require a 115V-20 amp receptacle to comply to the UL 1776 Standard.

Placement

Do not locate near any combustible material. Keep all flammable material at least 20 feet away.

Allow enough space for servicing the machine.

Local code will require certain distances from floor and walls. (Two feet away should be adequate.)

Water Source

Water source for machine should be supplied by a 5/8" I.D. garden hose with a city water pressure of not less than 30 psi. If the water supply is inadequate, or if the garden hose is kinked, the machine will run very rough and the burner will not fire.

Connection

Connect the wand, nozzle, hose and spray gun, where applicable (see Component Identification). On pipe thread connections, use Teflon tape to avoid water leaks.

Venting

Adding exhaust vent pipe to your oil fired burner is not recommended. The pipe restricts air flow which causes carbon buildup, which affects the operation, and increases maintenance on the coil. If a stack must be used, refrain from using 90° bends. If the pipe cannot go straight up then use only 45° bends and go to the next larger size pipe. The overall pipe length must not exceed 6 feet. The addition of a vent pipe will require an air adjustment and smoke test.

Operations

Assembly & Operation Instructions

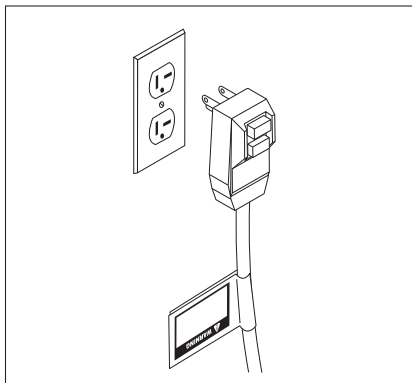

STEP 1: Connect the power cord into the proper electrical outlet, then push in the GFCI reset button. (Refer to serial plate for information.)

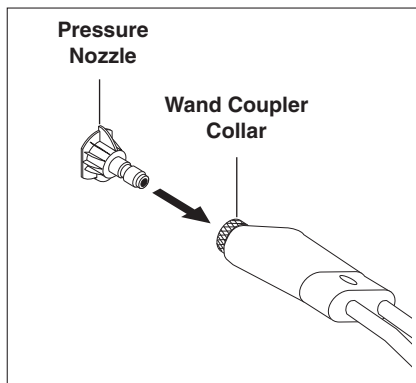

STEP 4: Pull the spring-loaded collar of the wand coupler collar back to insert your choice of pressure nozzle.

CAUTION: Never replace nozzles without engaging the safety latch on the spray gun trigger.

ATTENTION: Ne jamais remplacer les buses sans d'abord mettre le dispositif de sécurité sur la détente du pistolet pulvérisateur.

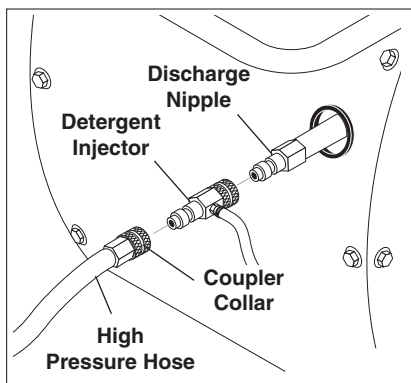

STEP 2: Connect high pressure hose to discharge nipple by sliding quick coupler collar back. (If detergent is to be applied, insert a detergent injector.) Insert quick coupler onto discharge nipple and secure by pushing quick coupler collar forward.

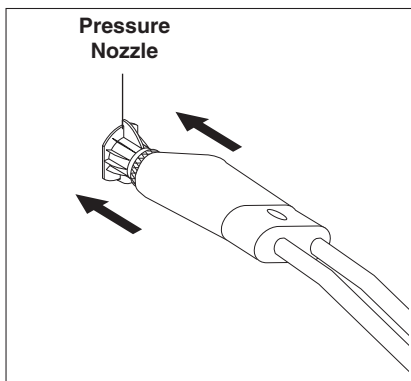

STEP 5: Release the coupler collar and push the nozzle until the collar clicks. Pull the nozzle to make sure it is seated properly.

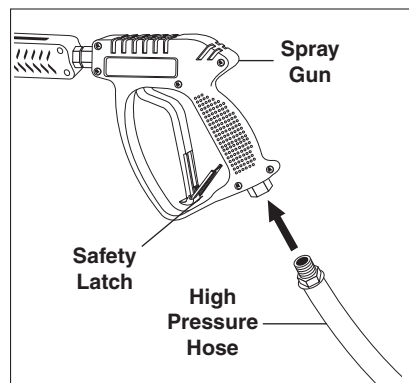

STEP 3: Attach the high pressure or steam wand hose to the spray gun using teflon tape on hose threads. Move safety latch into locked position.

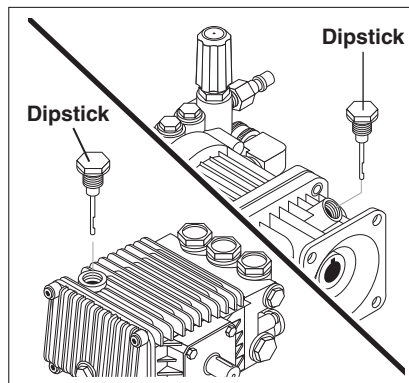

STEP 6: Check oil level by using supplied dip-stick. Use SAE 10W-40 non-foaming only.

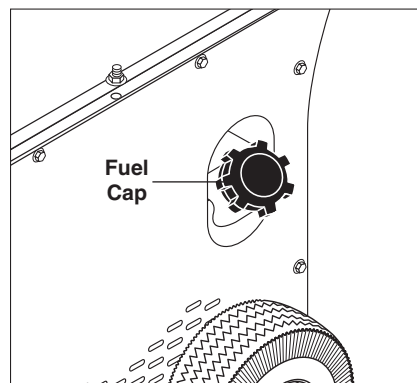

STEP 7: Fill fuel tank with proper fuel

Assembly & Operation Instructions

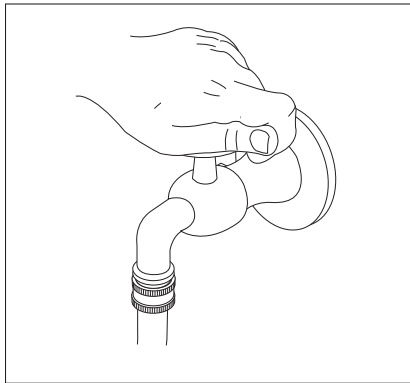

STEP 8: STOP! Read operator's manual before operating this machine. Failure to read operation and warning instructions may result in personal injury or property damage. Connect water supply hose to inlet connector and turn water on.

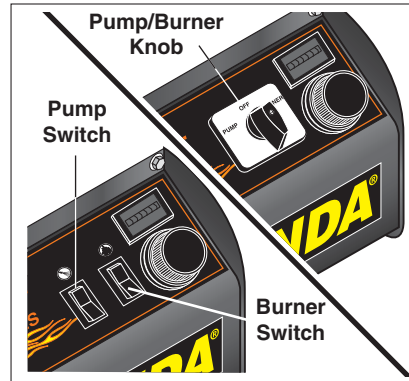

STEP 9: Before installing nozzle, turn on water supply and run machine, allowing water to flush through the system until clear. Turn pump switch ON or turn knob to pump position. When a steady stream of water flows from the spray gun and wand, the machine is ready for the high pressure nozzle to be installed. Turn the variable pressure control handle clockwise to raise the pressure. For hot water washing, turn the burner switch and thermostat ON or turn three position switch knob to the burner position. (The burner will light automatically.)

Operations

Insulated Straight Wand Assembly

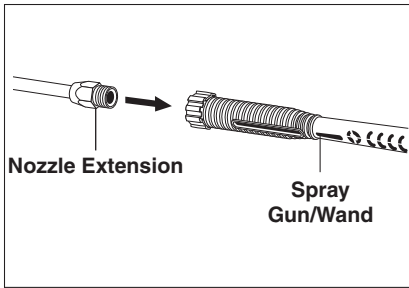

Attach the pressure hose to the spray gun using teflon tape on hose threads. Attach nozzle, extension to spray gun/wand. Tighten both by hand.

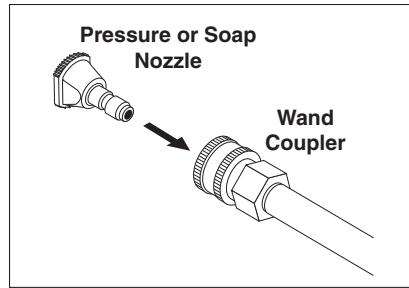

Before installing nozzle, turn on water supply and run machine allowing water to flush through the system until clear.

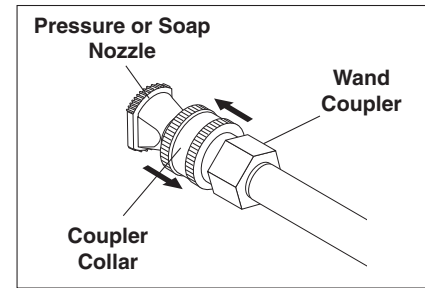

Pull spring-loaded collar of the wand coupler back to insert your choice of pressure nozzle or soap nozzle. Release the coupler collar and push the nozzle until the collar clicks. Pull the nozzle to make sure it is seated properly.

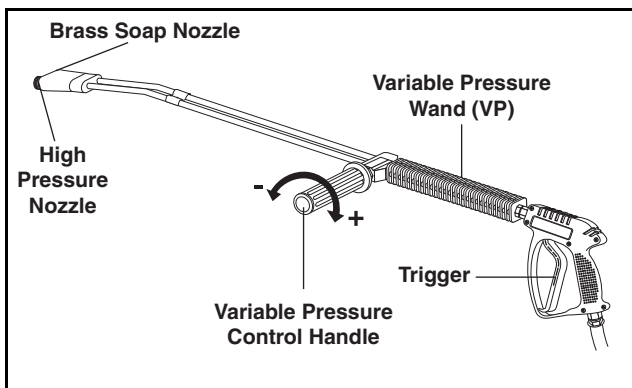

NOTE: High pressure nozzle must be inserted at end of wand to obtain high pressure.

Variable Pressure Wand Assembly

Models using variable pressure wands, grip spray gun securely. Turn variable pressure control handle counter-clockwise to reduce pressure and for applying soap through the brass soap nozzle with detergent injector attached.

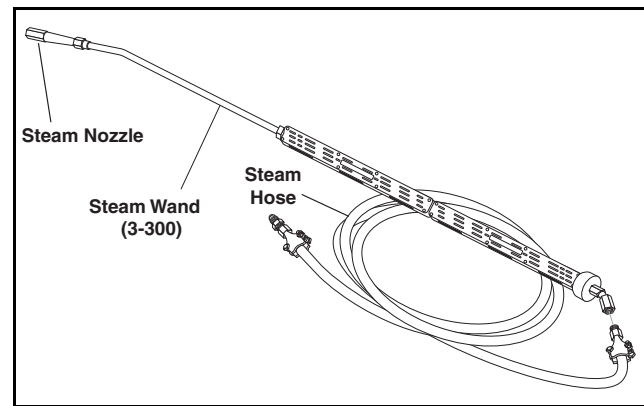

Steam Wand Assembly

This wand assembly is only used on midel HOT 3-30036D for steam. No high pressure or soap nozzle can be used.

Detergents & General Cleaning Techniques



WARNING: Some detergents may be harmful if inhaled or ingested, causing severe nausea, fainting or poisoning. The harmful elements may cause property damage or severe injury.

AVERTISSEMENT: Certains détergents peuvent être dangereux s'ils sont inhalés ou ingérés, provoquant de fortes nausées, des évanouissements et l'empoisonnement. Les éléments dangereux peuvent causer des dommages à la propriété ou des blessures graves.

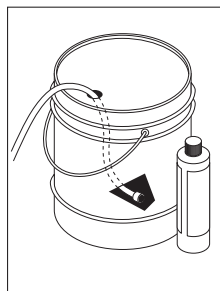

STEP 1: Use detergent designed specifically for pressure washers. Household detergents could damage the pump. Prepare detergent solution as required by the manufacturer. Fill a container with pressure washer detergent. Place the filter end of detergent suction tube into the detergent container.

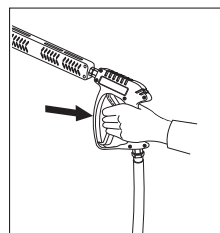

STEP 2: Apply safety latch to spray gun trigger. Secure black detergent nozzle into quick coupler at end of

insulated straight wand. See page 12 for variable pressure wand instructions.

NOTE: Detergent cannot be applied using the high pressure nozzle.

STEP 3: With the motor running, pull trigger to operate machine. Liquid detergent is drawn into the machine and mixed with water. Apply detergent to work area. Do not allow detergent to dry on surface.

IMPORTANT: You must flush the detergent injection system after each use by placing the suction tube into a bucket of clean water, then run the pressure washer in low pressure for 1-2 minutes.

Thermal Pump Protection

If you run your pressure washer for 3-5 minutes without pressing the trigger on the spray gun, circulating water in the pump can reach high temperatures. When the water reaches this temperature, the pump protector engages and cools the pump by discharging the warm water onto the ground. This thermal device prevents internal damage to the pump.

Cleaning Tips

Pre-rinse cleaning surface with fresh water. Place detergent suction tube directly into cleaning solution and apply to surface at low pressure (for best results, limit your work area to sections approximately 6 feet square and

always apply detergent from bottom to top). Allow detergent to remain on surface 1-3 minutes. Do not allow detergent to dry on surface. If surface appears to be drying, simply wet down surface with fresh water. If needed, use brush to remove stubborn dirt. Rinse at high pressure from top to bottom in an even sweeping motion keeping the spray nozzle approximately 1 foot from cleaning surface. Use overlapping strokes as you clean and rinse any surface. For best surface cleaning action, spray at a slight angle.

Recommendations:

- Before cleaning any surface, an inconspicuous area should be cleaned to test spray pattern and distance for maximum cleaning results.
- If painted surfaces are peeling or chipping, use extreme caution as pressure washer may remove the loose paint from the surface.
- Keep the spray nozzle a safe distance from the surface you plan to clean. High pressure wash a small area, then check the surface for damage. If no damage is found, continue to pressure washing.

CAUTION - Never use:

- Bleach, chlorine products and other corrosive chemicals
- Liquids containing solvents (i.e., paint thinner, gasoline, oils)
- Tri-sodium phosphate products
- Ammonia products
- Acid-based products

These chemicals will harm the machine and will damage the surface being cleaned.

ATTENTION: Ne jamais utiliser :

- Eau de Javel, produits à base de chlore et autres produits chimiques corrosifs
- Liquides contenant des solvants (c.-à-d. diluant à peinture, essence, huiles, etc.)
- Produits à base de tripolyphosphate de sodium
- Ammoniac ou produits à base d'acide

Ces produits chimiques endommageront la machine et endommageront la surface étant nettoyée.

Rinsing

It will take a few seconds for the detergent to clear. Apply safety latch to spray gun. Remove black soap nozzle from the quick coupler. Select and install the desired high pressure nozzle.

NOTE: You can also stop detergent from flowing by simply removing detergent siphon tube from bottle.

Operations

Shutting Down & Clean-up

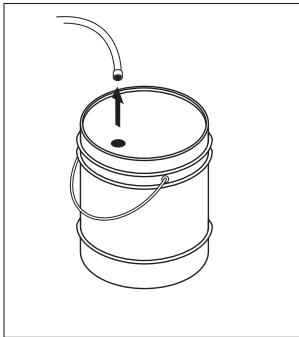

STEP 1: Remove detergent suction tube from container and insert into one (1) gallon of fresh water. Pull trigger on spray gun and siphon water for one minute.

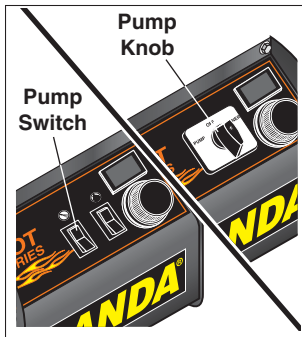

STEP 2: Turn pump switch ON or turn knob to pump position then open spray gun to allow water to cool.

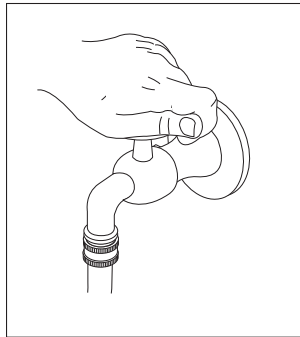

STEP 3: After water has cooled to less than 100°, turn switch or knob to OFF and turn off water.

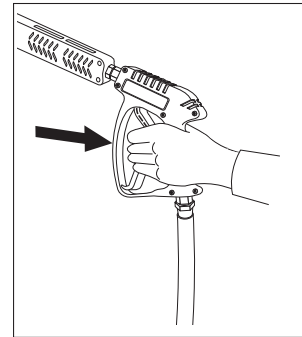

STEP 4: Squeeze trigger on spray gun to relieve remaining pressure. Move shut-off gun safety latch into its locked position.

Storage

CAUTION: Always store your pressure washer in a location where the temperature will not fall below 32°F (0°C). The pump in this machine is susceptible to permanent damage if frozen. **FREEZE DAMAGE IS NOT COVERED BY WARRANTY.**

ATTENTION: Toujours entreposer la laveuse à pression dans un endroit où la température ne sera pas inférieure à 32°C (0 °F). La pompe sur cette machine est susceptible de subir des dommages si elle est exposée au gel. **LES DOMMAGES DUS AU GEL NE SONT PAS COUVERTS PAR LA GARANTIE.**

1. Stop the pressure washer, squeeze spray gun trigger to release pressure.
2. Detach water supply hose and high pressure hose.
3. Turn on the machine for a few seconds, until remaining water exits. Turn engine off immediately.
4. Drain the gas and oil from the engine.
5. Do not allow high pressure hose to become kinked.
6. Store the machine and accessories in a room which does not reach freezing temperatures.

CAUTION: Failure to follow the above directions will result in damage to your pressure washer.

ATTENTION: Le non-respect des directives ci-dessus entraînera des dommages à la laveuse à pression

When the pressure washer is not being operated or is being stored for more than one month, follow these instructions:

1. Replenish engine oil to upper level.
2. Drain gasoline from fuel tank, fuel line, fuel valve and carburetor.
3. Pour about one teaspoon of engine oil through the spark plug hole, pull the starter grip several times and replace the plug. Then pull the starter grip slowly until you feel increased pressure which indicates the piston is on its compression stroke and leave it in that position. This closes both the intake and exhaust valves to prevent rusting of cylinder.
4. Cover the pressure washer and store in a clean, dry place that is well ventilated away from open flame or sparks.

NOTE: The use of a fuel additive, such as STABIL[®], or an equivalent, will minimize the formulation of fuel deposits during shortage. Such additives may be added to the gasoline in the fuel tank of the engine, or to the gasoline in a storage container.

After Extended Storage



CAUTION: Prior to restarting, thaw out any possible ice from pressure washer hoses, spray gun or wand.

ATTENTION: Avant de redémarrer, faire fondre la glace se trouvant sur les boyaux, le pistolet pulvérisateur ou la lance de la laveuse à pression

Engine Maintenance

During the winter months, rare atmospheric conditions may develop which will cause an icing condition in the carburetor. If this develops, the engine may run rough, lose power and may stall. This temporary condition can be

overcome by deflecting some of the Hot air from the engine over the carburetor area.

NOTE: Refer to the engine manufacturer's manual for service and maintenance of the engine.

Preventative Maintenance

1. Check to see that water pump is properly lubricated.
2. Follow Winterizing Procedures to prevent freeze damage to pump and coils.
3. Always neutralize and flush detergent from system after use.
4. If water is known to be high in mineral content, use a water softener on your water system, or descale as needed.
5. Do not allow acidic, caustic or abrasive fluids to be pumped through system.
6. Always use high grade quality Landa cleaning products.
7. Never run pump dry for extended periods of time.
8. Use clean fuel-kerosene, No. 1 fuel oil, or diesel. Replace fuel filter every 100 hours of operation. Avoid water contaminated fuel as it will seize up the fuel pump. Desoot coils monthly or use an additive if diesel is being used.
9. If machine is operated with smoky or eye burning exhaust, coils will soot up, not letting water reach maximum operating temperature (see Burner Adjustments).
10. Never allow water to be sprayed on or near the motor, the burner assembly or any electrical component.
11. Periodically descale coils per instructions.
12. Check to see that the motor is properly lubricate

It is advisable, periodically, to visually inspect the burner. Check air inlet to make sure it is not clogged or blocked. Wipe off any oil spills and keep this equipment clean and dry.

The areas around the Landa washer should be kept clean and free of combustible materials, gasoline and other flammable vapors and liquids.

The flow of combustion and ventilating air to the burner must not be blocked or obstructed in any manner.

Unloader Valves

Unloader valves trap pressure in the line when a spray gun is closed. Unloader valves are preset and tested at the factory before shipping. Tampering with the factory setting may cause personal injury and/or property damage, and will void the manufacturer's warranty.

Winterizing Procedure

Damage due to freezing is not covered by warranty. Adhere to the following cold weather procedures whenever the washer must be stored or operated outdoors under freezing conditions.

During winter months, when temperatures drop below 32°F, protecting your machine against freezing is necessary. Store the machine in a heated room. If this is not possible then mix a 50/50 solution of antifreeze and water into a 5 gallon bucket. Place a short section of garden hose into the bucket and connect it to the machine. Elevate the bucket and turn the pump on to siphon the antifreeze through the machine. If compressed air is available, screw an air fitting into the inlet connector. By injecting compressed air, all water will be blown out of the system.

High Limit Hot Water Thermostat

For safety, each machine is equipped with a high limit control switch. In the event the temperature of the water should exceed its operating temperature, the high limit control will turn the burner off until the water cools.

Pumps

Use only SAE 10W-40 weight non-foaming oil. Change oil after first 50 hours of use. Thereafter, change oil every year or at 500 hour intervals. Oil level should be checked through use of dipstick found on top of pump. Oil should be maintained at that level.

Cleaning of Coils

In alkaline water areas, lime deposits can accumulate rapidly inside the coil pipes. This growth is increased by the extreme heat build up in the coil. The best preventative for liming conditions is to use high quality cleaning detergents. In areas where alkaline water is an extreme problem, periodic use of Landa Coil Descaler (Landa Part #8.914-296.0) will remove lime and other deposits before coil becomes plugged. (

Periodic descaling of the heating coil is recommended so please consult your local Landa Dealer for instructions.

Maintenance

Rupture Disk

If pressure from pump or thermal expansion should exceed safe limits, the rupture disk will burst, allowing high pressure to be discharged through hose to ground. When the disk ruptures it will need to be replaced. Torque the replacement rupture disk to 35 foot pounds.

Fuel

Use clean fuel oil that is not contaminated with water and debris. Replace fuel filter and drain tank every 100 hours of operation. Use No. 1 or No. 2 Heating Oil (ASTM D306) only. **NEVER** use gasoline in your burner tank. Gasoline is more combustible than fuel oil and could result in a serious explosion. **NEVER** use crankcase or waste oil in your burner. Fuel unit malfunction could result from contamination.

Biodiesel fuels are becoming more popular as alternative fuels under the Green Initiative. Landa endorses the use of fuels that are blended with biodiesels meeting ASTM D6751 and petroleum fuels meeting ASTM D396. Landa offers no opinion regarding the combustion characteristics of B5 blends. B5 biodiesel fuels are 5% ASTM D6751 biodiesel and 95% ASTM D396 fuel oil blend.

Electrode Setting: Wayne

(See Illustration)

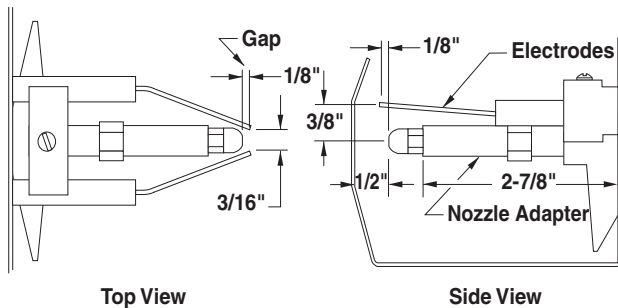

Periodically check wiring connections. If it is necessary to adjust electrodes, use diagram.

Electrode Setting: Beckett

(See Illustration)

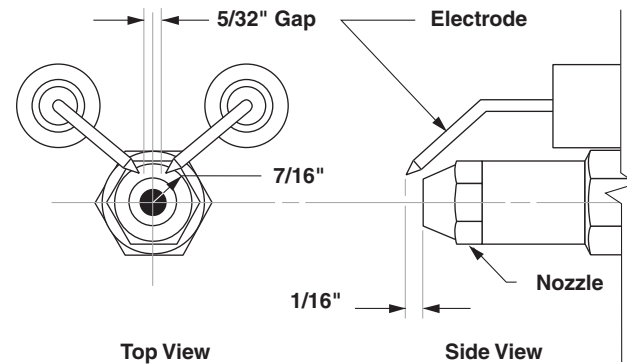

Ignition Circuit

Periodically inspect wires, spring contact and electrodes for condition, security and proper spacing. Transformer test: (**CAUTION 10,000 VOLTS**) use defect free insulated screwdriver and keep fingers off blade! Lay blade across one contact: OK if arc will span 1/2" between end of blade and other contact (see illustration below).

Transformer Check

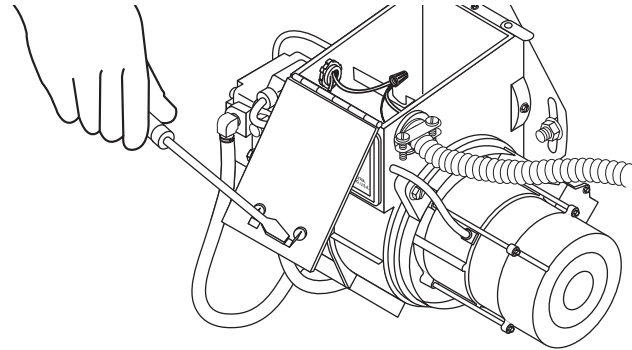

Burner Nozzle

Keep the tip free of surface deposits by wiping it with a clean, solvent-saturated cloth, being careful not to plug or enlarge the nozzle. For maximum efficiency, replace the nozzle each season.

Fuel Control System

These machines utilize a fuel solenoid valve located on the fuel pump to control the flow of fuel to the combustion chamber. This solenoid, which is normally closed, is activated by the unloader's pressure switch. When an operator releases the trigger on the spray gun, the unloader goes into a by-pass mode, thus stopping electrical current to the fuel solenoid coil. With the solenoid closed, the fuel supply to the combustion chamber ceases. Periodic inspection to insure that the fuel

solenoid valve functions properly is recommended. This can be done by operating the machine and checking to see that when the spray gun is in the OFF position the burner is not firing.

Fuel Pressure Adjustment

To adjust fuel pressure, turn the adjusting screw (located at the regulator port) clockwise to increase, counterclockwise to decrease. Do not exceed 200 psi.

NOTE: When changing fuel pump, a by-pass plug must be installed in return line port or fuel pump will not prime.

Air Adjustment

The oil burner on this machine is preset for operation altitudes below 1000 feet. If operated at higher altitudes, it may be necessary to adjust the air band setting. Adjust air band for a #1 or #2 smoke spot on the Bacharach scale.

If a smoky or eye-burning exhaust is being emitted from the stack, two things should be checked. First, check the fuel to be certain that kerosene or No. 1 home heating fuel is being used. Next, check the air adjustment on the burner. An oily, black, smoky fire indicates a lack of air and the air band should be moved to allow the air to flow through the burner. Sharp eye-burning white fumes indicate too much air flowing through the combustion chamber. The air band should be moved to allow less air to flow through the burner.

To Adjust: Start machine and turn burner ON. Loosen two locking screws found in the air shutter openings (refer to illustration) and close air shutter until black smoke appears from burner exhaust vent. Note air band position. Next, slowly open the air shutter until

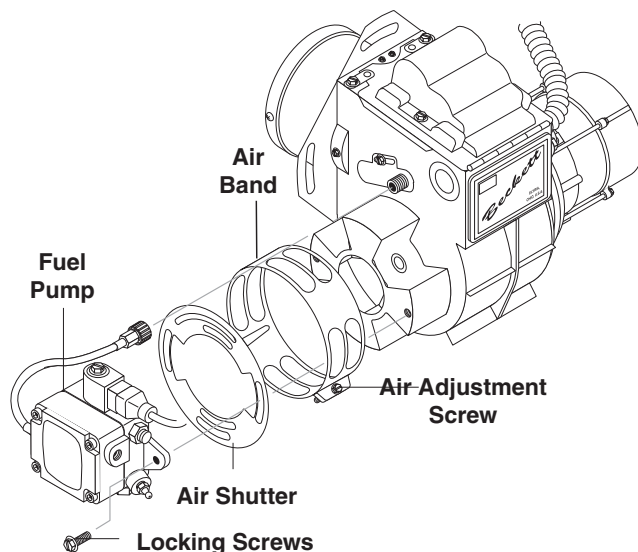

white smoke just starts to appear. Turn air shutter halfway back to the black smoke position previously noted. Tighten locking screws.

If the desired position cannot be obtained using only the air shutter, lock the air shutter in as close a position as can be obtained, then repeat the above procedure on the air band setting.

Initial Air Adjustments: Allow sufficient air to obtain a clean burning flame by loosening the lock screws and moving the air shutter and if necessary the bulk air band.

Reduce the air supply until the flame tips appear slightly smoky, then increase the air just enough to cause the flame tips to appear absolutely clean.

Removal of Soot and Heating Coil

In the heating process, fuel residue in the form of soot deposits may develop between the heating coil pipe and block air flow which will affect burner combustion. When soot has been detected on visual observation, the soot on the coil must be washed off. Follow these steps to remove the coil.

1. Disconnect hose from pump to inlet side of the coil.
2. Disconnect electrical connection to the thermostat.
3. Remove quick coupler from inlet and discharge side of coil.
4. Remove burner assembly from combustion chamber.
5. Remove the 3-3/8" bolts from each side of coil and tank assembly (these bolts are used to fasten tank and handles to chassis).
6. Disconnect 1/2" pipe nipples from inlet and discharge side of coil.
7. Remove top tank wrap exposing insulation and coil and fold back insulation.
8. Remove bolts that hold down coil to bottom wrap.
9. Remove coil.
10. Replace or repair any insulation found to be torn or broken.

Coil Reinstallation

Reinstall new or cleaned coil by reversing Steps 9 through 1 above.

Troubleshooting

PROBLEM	POSSIBLE CAUSE	SOLUTION
LOW OPERATING PRESSURE	Faulty pressure gauge	Install new gauge.
	Insufficient water supply	Use larger garden hose; clean filter washer at water inlet.
	Old, worn or incorrect spray nozzle	Match nozzle number to machine and/or replace with new nozzle.
	Plumbing or hose leak	Check plumbing system for leaks. Re-tape leaks with teflon tape.
	Faulty or mis-adjusted unloader valve (Where applicable)	Adjust unloader for proper pressure. Install repair kit when needed.
	Worn packing in pump	Install new packing kit.
	Fouled or dirty inlet or discharge valves in pump	Clean inlet and discharge valves.
	Worn inlet or discharge valves	Replace with valve kit.
LOW WATER TEMPERATURE	Soot buildup on coils not allowing heat transfer	Clean coils.
	Lime deposits on inside of coil	Delime coil.
WATER TEMPERATURE TOO HOT	Defective high limit switch	Replace.
	Insufficient water supplied	Check water G.P.M. to machine.
	Restricted water flow	Check nozzle for proper size or obstruction.
DETERGENT NOT DRAWING	Air leak	Tighten all clamps. Check detergent lines for holes.
	Valve in the injector head may be blocked, dirty or damaged	Clean or replace valve in injector.
	Filter screen on detergent suction hose plugged	Clean or replace.
	Dried up detergent plugging metering valve	Disassemble and clean thoroughly.
	High viscosity of detergent	Dilute detergent to specifications.
	Hole in detergent line(s)	Repair hole.
	Low detergent level	Add detergent, if needed.
	Variable pressure control handle set for high pressure	Turn variable pressure control handle to allow water to flow out of brass soap nozzle.

Maintenance

Troubleshooting

PROBLEM	POSSIBLE CAUSE	SOLUTION
PUMP RUNNING NORMALLY BUT PRESSURE LOW ON INSTALLATION	Pump sucking air	Check water supply and possibility of air seepage.
	Valves sticking	Check and clean or replace if necessary.
	Unloader valve seat faulty	Check and replace if necessary.
	Nozzle incorrectly sized	Check and replace if necessary (See serial plate for proper size).
	Worn piston packing	Check and replace if necessary.
FLUCTUATING PRESSURE	Valves worn	Check and replace if necessary.
	Blockage in valve	Check and replace if necessary.
	Pump sucking air	Check water supply and air see page at joints in suction line.
	Worn piston packing	Check and replace if necessary.
PUMP NOISY	Air in suction line	Check water supply and connections on suction line.
	Broken or weak inlet or discharge valve springs	Check and clean if necessary.
	Excessive matter in valves	Check and clean if necessary.
	Worn bearings	Check and clean if necessary.
PRESENCES OF WATER IN OIL	Oil seal worn	Check and replace if necessary.
	High humidity in air	Check and change oil twice as often.
WATER DRIPPING FROM UNDER PUMP	Piston packing worn	Check and replace if necessary.
	O-Ring plunger retainer worn	Check and replace if necessary.
	Pump protector	Reduce inlet water pressure. Do not close trigger on spray gun for longer than 1-2 minutes.
OIL DRIPPINGS	Oil seal worn	Check and replace if necessary.
MACHINE SMOKES	Improper fuel or water in fuel	Drain tank and replace contaminated fuel.
	Improper air adjustment	Readjust air bands on burner assembly.
	Low fuel pressure	Adjust fuel pump pressure to specifications.
	Weak fuel pump	Check fuel pump pressure. Replace pump if needed.
	Fuel filter partially clogged	Replace as needed.
	Soot build up on coils	Clean coils with soot remover.
	Lime build up in coils	Clean inside of coils using Landa's coil cleaner.
	Improper burner nozzle	See combustion assembly breakdown

PROBLEM	POSSIBLE CAUSE	SOLUTION
WATER TEMPERATURE TOO HOT	Incoming water to machine warm or hot	Lower incoming water temperature.
	Fuel pump pressure too high	Lower fuel pressure.
	Fuel pump defective	Replace fuel pump.
	Detergent line sucking air	Tighten all clamps. Check detergent line for holes.
	Defective high limit switch	Replace.
	Incorrect fuel nozzle size	See exploded view parts list for proper size.
	Insufficient water supplied	Check G.P.M. to machine.
	Restricted water flow	Check nozzle for obstruction, proper size.
BURNER LIGHT WILL NOT LIGHT	Disconnected or short in electrical wiring	All wire contacts should be clean and tight. No breaks in wire.
	Burner motor thermal protector tripped	If tripped, check voltage, connections, and extensions for cause. Check fuel pump shaft rotation for binding causing motor to overheat.
	Flex-coupling slipping on fuel pump shaft or burner motor shaft	Replace if needed.
	ON-OFF Switch defective	Check continuity through burner switch.
	Heavy sooting on coil and burner, can cause interruption of air flow and shorting of electrodes	Clean as required.
	Improper electrode setting	Clean and test according to diagram in Operators Manual.
	Fuel not reaching combustion chamber	Check fuel pump for proper flow. Check solenoid flow switch on machines with spray gun control, for proper on-off fuel flow control.
	Clogged burner nozzle	Replace.
	Water not turned on	Turn on water to activate burner flow switch.
	Fuel solenoid malfunction	Remove, test for continuity and replace as needed.
	Fuel solenoid malfunction	Replace if needed.
	Pressure switch malfunction	Test for proper operation. Replace if needed.
PUMP MOTOR STOPS AFTER A FEW MINUTES OF OPERATION OR STARTS SLOW	Insufficient voltage	Use heavier drop cord and check voltage at receptacle. Check name plate for amperage draw.
	Plugged nozzle	Remove and clean nozzle. Turn on water pump, flush lines, and replace nozzle.
	Wrong spray nozzle	See serial plate for minimum nozzle size.
	Automatic overload switch tripped	Allow motor to cool - then push Red reset button.
	Motor wet	Allow to dry.
	Short in electrical wiring	Wire contacts should be clean and tight. No breaks in wires.
	Coil liming up causing excessive pressure	See section on Preventative Maintenance.
	Water pump low or out of oil causing the pump to bind up	Fill to correct level.

LANDA[®]

8.917-208.0 • Printed in U.S.A.