

# HDS Series

Hot Water - Electric Powered - Diesel Heated

# KÄRCHER

## Operator's Manual

## Pressure Washer

**MODELS:** HDS 3.9/20 Ea Cage  
1.575-505.0

HDS 3.5/30 Ea Cage  
1.575-508.0

HDS 3.5/30 Eb Cage  
1.575-509.0

HDS 3.5/30 Ec Cage  
1.575-510.0

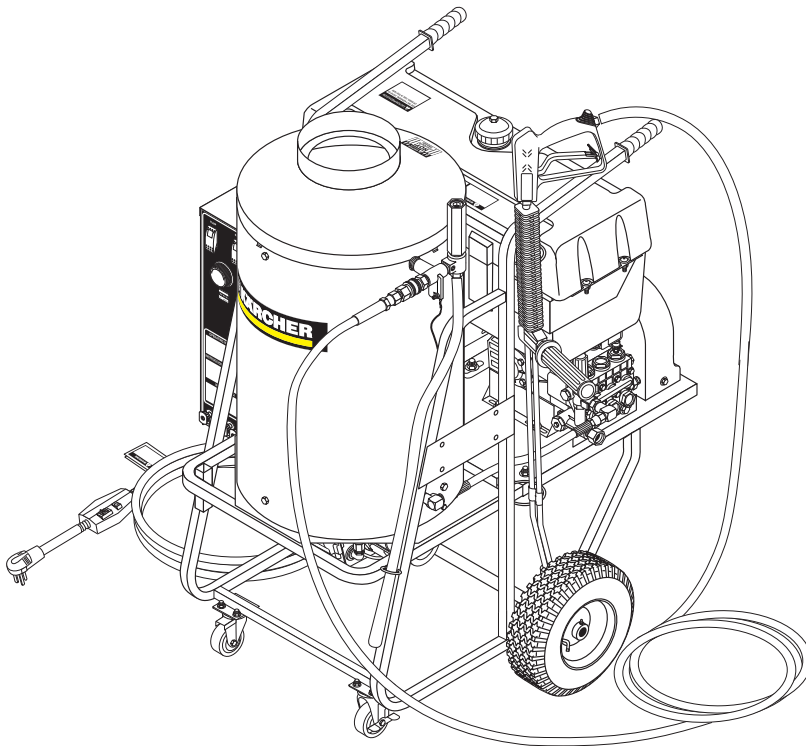

# SHOP PRESSURE WASHER PARTS

shoppressurewasherparts.com | (888) 269-0172



9.800-078.0-R 10/10/17

*Machine Data Label*

---

Model: \_\_\_\_\_

Date of Purchase: \_\_\_\_\_

Serial Number: \_\_\_\_\_

Dealer: \_\_\_\_\_

Address: \_\_\_\_\_

Phone Number: \_\_\_\_\_

Sales Representative: \_\_\_\_\_

**Machine Data Label . . . . .2**  
**Table of Contents . . . . .3**  
**How To Use This Manual . . . . .4**

*Safety*

Introduction & Safety Information . . . . .5  
 Important Safety Information. . . . .6

*Operations*

Component Identification . . . . .9  
 Assembly Instructions . . . . .10  
 Installation . . . . .11  
 Operating Instructions . . . . .12  
 Detergents & General Operating Techniques . . . . .13  
 Thermal Pump Protection . . . . .13  
 Cleaning Tips . . . . .13  
 Rinsing . . . . .13  
 Shutting Down And  
     Clean-Up . . . . .14  
 Storage . . . . .15

*Maintenance*

Preventative Maintenance . . . . .16  
 Maintenance And Service . . . . .16  
 Unloader Valves . . . . .16  
 Winterizing Procedure . . . . .16  
 High Limit Hot Water Thermostat . . . . .16  
 Pumps . . . . .16  
 Cleaning of Coils . . . . .17  
 Rupture Disk . . . . .17  
 Fuel . . . . .17  
 Ignition Circuit . . . . .17  
 Electrode Setting . . . . .18  
 Burner Nozzle . . . . .18  
 Oil Burner . . . . .19  
 Maintenance Charts . . . . .20

*Parts*

Karcher HDS 1.575-505.0, 508.0, 509.0, 510.0 . . . . .26  
 Control Panel - 1.575-505.0, 508.0, 509.0, 510.0. . . . .30  
 Float Tank - 505.0, 508.0, 509.0, 510.0 . . . . .32  
 Auto Start / Stop 505.0, 508.0, 509.0, 510.0 . . . . .35  
 Auto Start / Stop - Steam Options 505.0, 508.0,  
     509.0, 510.0 . . . . .36  
 Pump - 1.575-505.0, 508.0, 509.0, 510.0 . . . . .38  
 Steam Options - 1.575-505.0, 508.0, 509.0, 510.0 . . . . .39  
 Hose & Spray Gun . . . . .40  
 UU1 Unloader Valve . . . . .42  
 KM.3 Series Pump . . . . .44  
 Wayne Burner . . . . .46  
 Specifications . . . . .48

## How To Use This Manual

This manual contains the following sections:

- How to Use This Manual
- Safety
- Operations
- Maintenance
- Parts List

The HOW TO USE THIS MANUAL section will tell you how to find important information for ordering correct repair parts.

Parts may be ordered from authorized dealers. When placing an order for parts, the machine model and machine serial number are important. Refer to the MACHINE DATA box which is filled out during the installation of your machine. The MACHINE DATA box is located on the inside of the front cover of this manual.

Model: _____
Date of Purchase: _____
Serial Number: _____
Dealer: _____
Address: _____
Phone Number: _____
Sales Representative: _____

The model and serial number of your machine will be found on a decal attached to the pressure washer.

The SAFETY section contains important information regarding hazardous or unsafe practices of the machine. Levels of hazards are identified that could result in product damage, personal injury, or severe injury resulting in death.

The OPERATIONS section is to familiarize the operator with the operation and function of the machine.

The MAINTENANCE section contains preventive maintenance to keep the machine and its components in good working condition. They are listed in this general order:

- Preventative Maintenance
- Maintenance And Service
- Unloader Valves
- Winterizing Procedure
- High Limit Hot Water Thermostat
- Pumps
- Cleaning of Coils
- Rupture Disk
- Fuel
- Ignition Circuit
- Electrode Setting
- Burner Nozzle
- Karcher Clearfire Oil Burner
- Burner Air Adjustment
- Maintenance Charts
- Oil Change Record
- Troubleshooting

The PARTS LIST section contains assembled parts illustrations and corresponding parts list. The parts lists include a number of columns of information:

- **REF** – column refers to the reference number on the parts illustration.
- **PART NO.** – column lists the part number for the part.
- **QTY** – column lists the quantity of the part used in that area of the machine.
- **DESCRIPTION** – column is a brief description of the part.
- **NOTES** – column for information not noted by the other columns.

*NOTE: If a service or option kit is installed on your machine, be sure to keep the KIT INSTRUCTIONS which came with the kit. It contains replacement parts numbers needed for ordering future parts.*

*NOTE: The manual part number is located on the lower right corner of the front cover.*

## **Introduction & Safety Information**

**Thank you for purchasing this Pressure Washer.**

**We reserve the right to make changes at any time without incurring any obligation.**

### **Owner/User Responsibility**

The owner and/or user must have an understanding of the manufacturer's operating instructions and warnings before using this pressure washer. Warning information should be emphasized and understood. If the operator is not fluent in English, the manufacturer's instructions and warnings shall be read to and discussed with the operator in the operator's native language by the purchaser/owner, making sure that the operator comprehends its contents.

Owner and/or user must study and maintain for future reference the manufacturers' instructions.

The operator must know how to stop the machine quickly and understand the operation of all controls. Never permit anyone to operate the engine without proper instructions.

### **SAVE THESE INSTRUCTIONS**

**This manual should be considered a permanent part of the machine and should remain with it if machine is resold.**

**When ordering parts, please specify model and serial number. Use only identical replacement parts.**

**This machine is to be used only by trained operat**

## Important Safety Information



**WARNING:** To reduce the risk of injury, read operating instructions carefully before using.

**AVERTISSEMENT:** Pour réduire le risque de blessures, lire attentivement les instructions de fonctionnement avant l'utilisation.

1. Read the owner's manual thoroughly. Failure to follow instructions could cause malfunction of the machine and result in death, serious bodily injury and/or property damage.
2. Know how to stop the machine and bleed pressure quickly. Be thoroughly familiar with the controls.
3. Stay alert — watch what you are doing.
4. All installations must comply with local codes. Contact your electrician, plumber, utility company or the selling dealer for specific details. If your machine is rated 250 volts or less, single phase a ground fault circuit interrupter (GFCI) will be provided. If rated more than 250 volts, or more than single phase this product should only be connected to a power supply protected by a GFCI.

**DANGER:** Improper connection of the equipment-grounding conductor can result in a risk of electrocution. Check with a qualified electrician or service personnel if you are in doubt as to whether the outlet is properly grounded. Do not modify the plug provided with the product - if it will not fit the outlet, have a proper outlet installed by a qualified electrician. Do not use any type of adapter with this product

**DANGER :** Une mauvaise connexion du conducteur de terre de l'équipement peut entraîner un risque d'électrocution. Vérifier auprès d'un électricien qualifié ou du personnel d'entretien si vous avez des doutes quant à savoir si la sortie est correctement mise à la masse.



**DANGER:** Keep wand, hose, and water spray away from electric wiring or fatal electric shock may result.

**DANGER :** Garder la lance, le boyau et le jet d'eau à l'écart de tout câblage électrique ou des chocs électriques mortels pourraient survenir.

5. To protect the operator from electrical shock, the machine must be electrically grounded. It is the responsibility of the owner to connect this machine to a UL grounded receptacle of proper voltage and amperage ratings. Do not spray water on or near electrical components. Do not touch machine with wet hands or while standing in water. Always disconnect power before servicing.



**WARNING:** Flammable liquids can create fumes which can ignite, causing property damage or severe injury.

**AVERTISSEMENT :** Des liquides inflammables peuvent produire des vapeurs qui peuvent s'enflammer, causant ainsi des dommages à la propriété ou des blessures graves.

graves.

**WARNING:** Risk of explosion — Operate only where open flame or torch is permitted.

**AVERTISSEMENT :** Risque d'explosion - Utiliser uniquement dans des endroits où l'utilisation d'une flamme nue ou d'une torche est permise.

6. In oil burning models, use only kerosene, No. 1 home heating fuel, or diesel. If diesel is used, add a soot remover to every tankful.



**WARNING:** Risk of fire — Do not add fuel when the product is operating or still hot.

**AVERTISSEMENT :** Risque d'incendie - Ne pas ajouter de carburant pendant que la machine fonctionne ou est encore chaude.

**WARNING: Do not use gasoline crankcase draining or oil containing gasoline, solvents or alcohol. Doing so will result in fire and/or explosion.**

**AVERTISSEMENT : Ne pas utiliser d'essence, de drainage du carter de moteur ou d'essence contenant de l'huile, de solvants ou de l'alcool. Ne pas traiter les solvants, les huiles pures, etc. Agir de la sorte risquerait de créer un incendie et/ou une explosion.**

7. Oil burning appliances shall be installed only in locations where combustible dusts and flammable gases or vapors are not present. Do not store or use gasoline near this machine.
8. Do not allow acids, caustic or abrasive fluids to pass through the pump.
9. Never run pump dry or leave spray gun closed longer than 1-2 minutes.
10. Keep operating area clear of all persons.



**WARNING: High pressure spray can cause paint chips or other particles to become airborne and fly at high speeds. To avoid personal injury, eye, hand and foot safety devices must be worn.**

**AVERTISSEMENT : Un jet haute pression peut écailler la peinture ou provoquer l'émission d'autres particules dans**

**l'air et leur projection à hautes vitesses. Pour éviter les lésions corporelles, une protection des yeux, du visage, des mains et des pieds doit être portée lors de l'utilisation de cet équipement.**

Always wear properly rated eye protection such as safety goggles or face shield while spraying. (Safety glasses do not provide full protection.)



**WARNING: This machine exceeds 85 db. Appropriate ear protection must be worn.**

**AVERTISSEMENT : Cette machine excède 85 dB et une protection de l'ouïe appropriée doit être portée.**



**WARNING: Hot discharge fluid. Do not direct discharge stream at persons or animals.**

**AVERTISSEMENT : Liquide de décharge chaud. Ne pas décharger directement le jet vers des personnes ou des animaux, car cela risquerait de causer des blessures graves ou même la mort.**

**WARNING: This machine produces hot water and must have insulated components attached to protect the operator.**

**AVERTISSEMENT : Cette machine produit de l'eau chaude et doit comporter des composants isolés attachés pour protéger l'opérateur.**



**WARNING: Risk of injury. Hot surfaces can cause burns. Use only designated gripping areas of spray gun and wand. Do not place hands or feet on non-insulated areas of the pressure washer.**

**AVERTISSEMENT : Risque de blessures. Les surfaces chaudes peuvent causer des brûlures. Utiliser uniquement**

**les zones de prise désignées du pistolet pulvérisateur et de la lance. Ne pas placer les mains ou les pieds sur des endroits non isolés de la laveuse à pression.**

11. To reduce the risk of injury, close supervision is necessary when a machine is used near children. Do not allow children to operate the pressure washer. **This machine must be attended during operation.**



**WARNING: Grip cleaning wand securely with both hands before starting. Failure to do this could result in injury from a whipping wand.**

**AVERTISSEMENT : Agripper la lance de nettoyage avec les deux mains avant de commencer. Le non-respect de cette consigne pourrait mener à des blessures causées par le**

**mouvement violent de la lance.**

12. Never make adjustments on machine while in operation.

13. Be certain all quick coupler fittings are secured before using pressure washer.



**WARNING:** High pressure developed by these machines will cause personal injury or equipment damage. Keep clear of nozzle. Use caution when operating. Do not direct discharge stream at people or animals, or severe injury or death will result.

**AVERTISSEMENT :** La haute pression générée par ces machines causera des lésions corporelles ou des dommages à l'équipement. Se tenir à l'écart de la buse. Faire preuve de prudence lors de l'utilisation. Ne pas décharger directement le jet vers des personnes ou des animaux, car cela risquerait de causer des blessures graves ou même la mort.



**WARNING:** Protect machine from freezing.

**AVERTISSEMENT :** Protéger la machine contre le gel.

14. To keep machine in best operating conditions, it is important you protect machine from freezing. Failure to protect machine from freezing could cause malfunction of the machine

and result in death, serious bodily injury, and/or property damage. Follow storage instructions specified in this manual.

15. Inlet water must be clean fresh water and no hotter than 90°F.



**DANGER:** Risk of asphyxiation. Use this product only in a well ventilated area.

**DANGER :** Risque d'asphyxie. Utiliser ce produit uniquement dans un endroit bien ventilé.

16. Avoid installing machines in small areas or near exhaust fans. Adequate oxygen is needed for combustion or dangerous carbon

monoxide will result.

17. Manufacturer will not be liable for any changes made to our standard machines or any components not purchased from us.

18. The best insurance against an accident is precaution and knowledge of the machine.



**WARNING:** Be extremely careful when using a ladder, scaffolding or any other relatively unstable location. The cleaning area should have adequate slopes and drainage to reduce the possibility of a fall due to slippery surfaces.

**AVERTISSEMENT :** Faire preuve d'une extrême prudence au moment d'utiliser une échelle, des échafaudages ou toute autre surface relativement instable. La zone de nettoyage doit avoir une pente et un drainage adéquats pour réduire la possibilité d'une chute due à une surface glissante.

19. Do not overreach or stand on unstable support. Keep good footing and balance at all times..Do not operate this machine when fatigued or under the influence of alcohol, prescription medications, or drugs.



**WARNING:** Do not spray machine or any people, animals or electrical parts.

**AVERTISSEMENT :** Ne pas vaporiser sur la machine ou les gens, les animaux ou les pièces électriques.



**WARNING:** If connection is made to a potable water system, the system shall be protected against backflow.

**AVERTISSEMENT :** Si une connexion est établie avec un réseau d'eau potable, le réseau doit être protégé contre le retour d'eau.



Follow the maintenance instructions specified in the manual.



Component Identification

**CAUTION HOT WATER:**  
Must use insulated  
spray gun and wand.

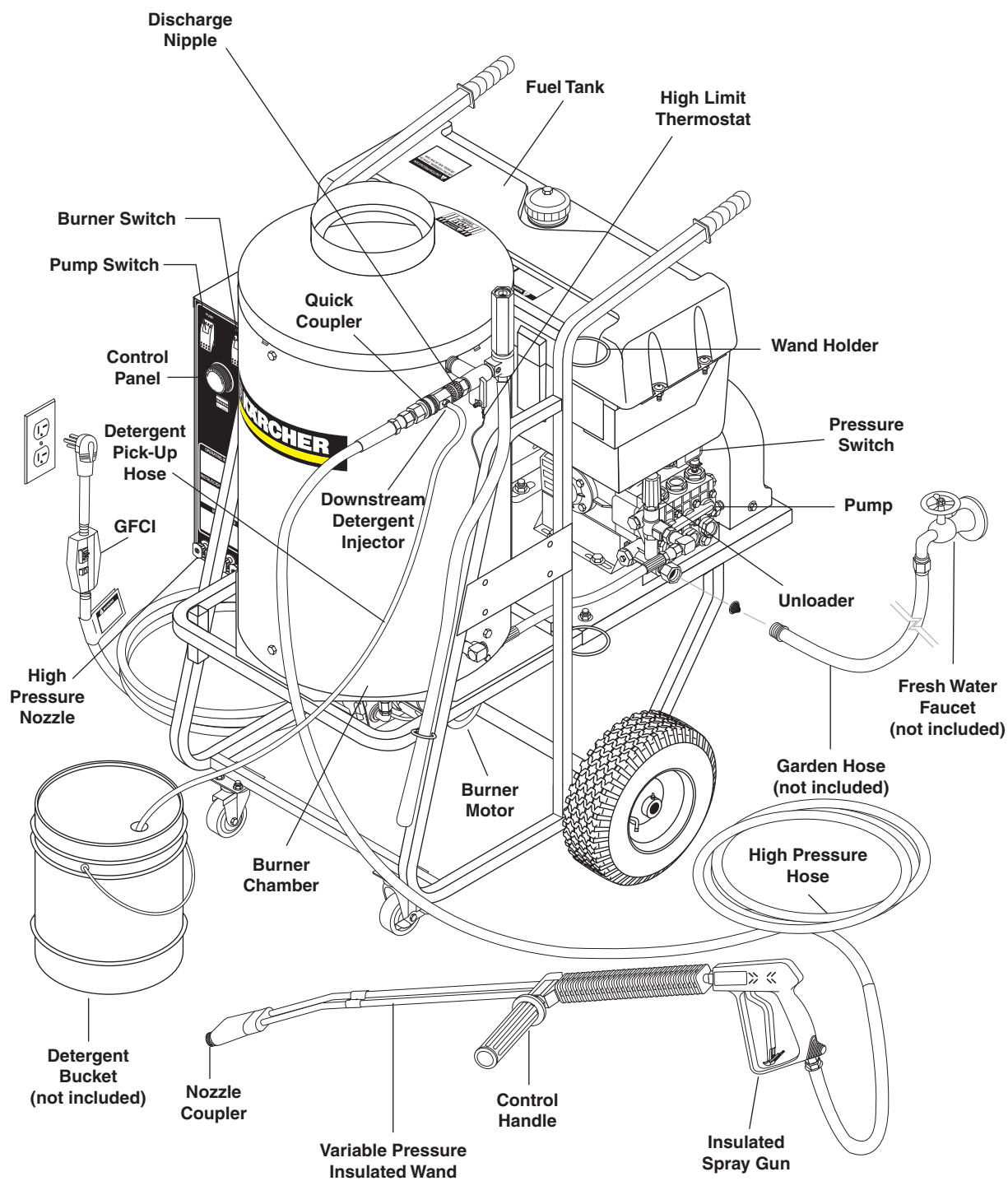

## Assembly Instructions

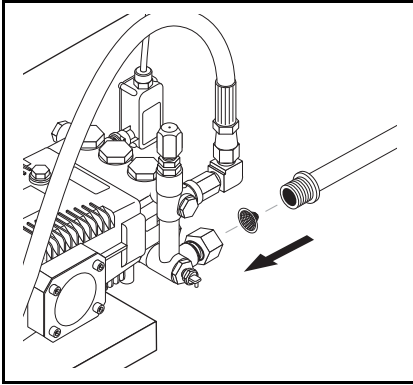

**STEP 1:** Connect water supply hose.

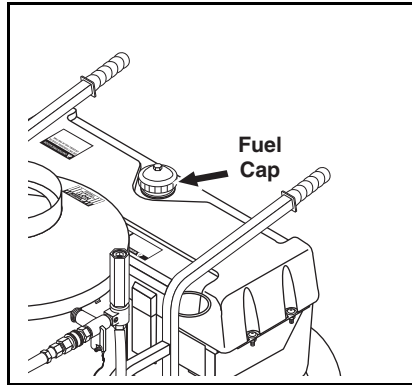

**STEP 2:** Check fuel tank and pump oil levels.

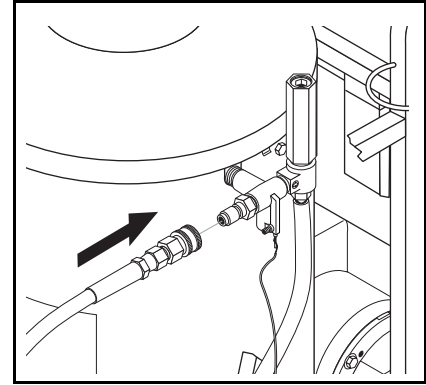

**STEP 3:** Connect high pressure hose to discharge nipple by sliding quick coupler collar back. Insert quick coupler onto discharge nipple and secure by pushing quick coupler collar forward.

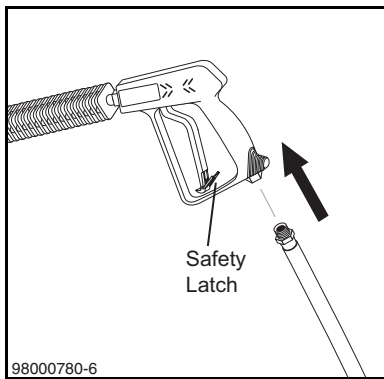

**STEP 4:** Engage the spray gun safety latch. Attach the high pressure hose to the spray gun using teflon tape on hose threads.

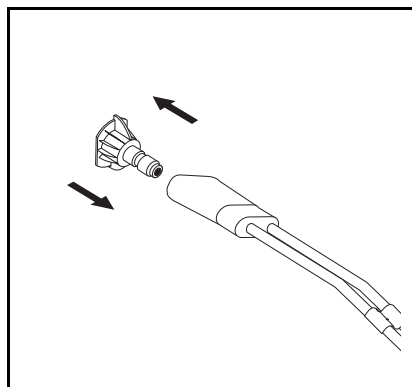

**STEP 5:** Connect the high pressure nozzle to the wand quick coupler by sliding coupler collar back. Push coupler collar forward until secure.

## Installation

Place machine in a convenient location providing ample support, draining and room for maintenance.

**This machine is intended for outdoor use. Machine must be stored indoors when not in use.**

## Location

The location should protect the machine from damaging environmental conditions, such as wind, rain, and freezing.

1. This machine should be run on a level surface where it is not readily influenced by outside sources such as strong winds, freezing temperatures, rain, etc. It should be located to allow accessibility for refilling of fuel, adjustments and maintenance. Normal precautions should be taken by the operator of the machine to prevent moisture from reaching the electrical controls.
2. It is recommended that a partition be made between the wash area and the machine to prevent water spray from coming in contact with the machine. Excess moisture reaching any electric components or electrical controls will reduce machine life and may cause electrical shorts.
3. During installation of the machine, beware of poorly ventilated locations or areas where exhaust fans may cause an insufficient supply of oxygen. Sufficient combustion can only be obtained when there is a sufficient supply of oxygen available for the amount of fuel being burned. If it is necessary to install a machine in a poorly ventilated area, outside fresh air may have to be piped to the burner and a fan installed to bring air into the machine.

**Avoid small locations or areas near exhaust fans.**

## Electrical

This machine, when installed, must be electrically grounded in accordance to local codes. Check for proper power supply using a volt meter.

## Placement

Do not locate near any combustible material. Keep all flammable material at least 20 feet away.

Allow enough space for servicing the machine.

Local code will require certain distances from floor and walls. (Two feet away from walls should be adequate.)

## Water Source

The water source for the pressure washer should be supplied by a minimum 5/8" I.D. garden hose with a city water pressure of not less than 30 PSI. If the water supply is inadequate, or if the garden hose is kinked, the attached pressure washer will run very rough and the burner will not fire.

## Connection

Connect the wand, nozzle, hose and spray gun (where applicable). On pipe thread connections, use teflon tape to avoid water leaks. (See Component Identification).

## Venting

Adding exhaust vent pipe to your oil fired burner is not recommended because restricted air flow causes carbon build-up, which affects the operation, and increases maintenance on the coil. If a stack must be used, refrain from using 90° bends. If the pipe can not go straight up then use only 45° bends and go to the next size pipe. The overall pipe length must not exceed 6 feet in length\*.

*NOTE: After vent pipe installation test burner using a smoke tester and adjust air setting to achieve a #3 or below results.*

**Operating Instructions**

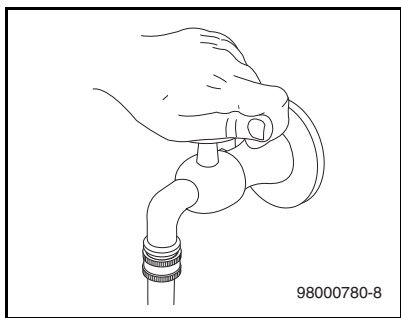

**STEP 1:** Turn water on.

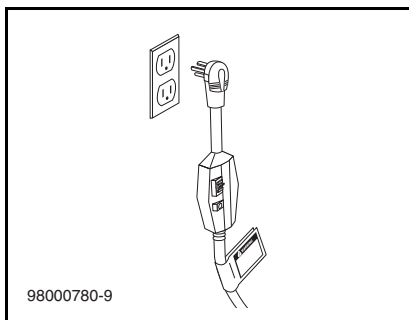

**STEP 2:** Connect the power cord into the proper electrical outlet, then push in the GFCI reset button. (Refer to serial plate for information).

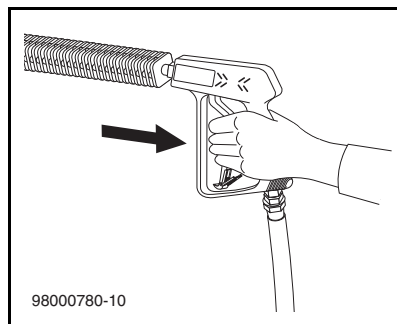

**STEP 3:** Grip spray gun handle securely and pull trigger. Then turn variable pressure control handle counterclockwise.

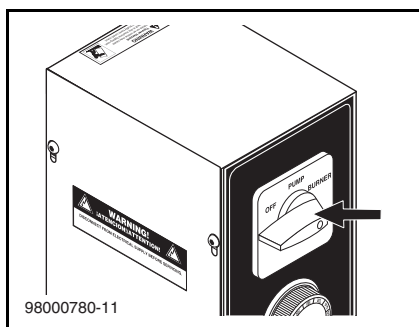

**STEP 4:** Before installing nozzle, turn on water supply and run machine, allowing water to flush through the system until clear.

Turn switch to pump position. When a steady stream of water flows from the spray gun and wand the machine is ready for cold water cleaning by turning the variable pressure control handle clockwise to raise the pressure.

For hot water washing, turn the switch to the burner position. (The burner will light automatically when the trigger on the spray gun is pulled.)

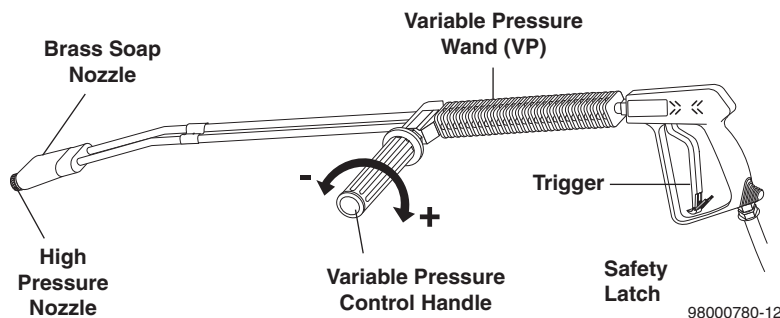

Selection of high or low pressure is accompanied by turning the handle. **NOTE:** High pressure nozzle must be inserted at end of wand to obtain high pressure. To apply soap read operator's manual.

## Detergents & General Operating Techniques

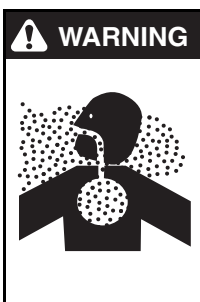

**WARNING:** Some detergents may be harmful if inhaled or ingested, causing severe nausea, fainting or poisoning. The harmful elements may cause property damage or severe injury.

**STEP 1:** Connect detergent injector to discharge nipple on machine, Connect high pressure hose to injector with quick coupler

(check to make sure locking coupler sleeves are in proper position before applying water pressure.

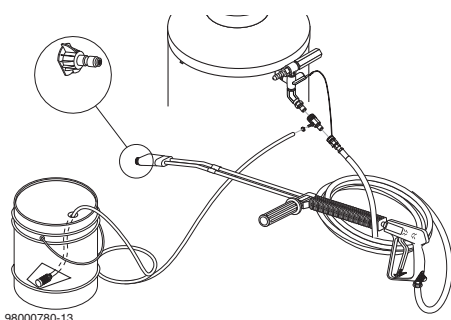

98000780-13

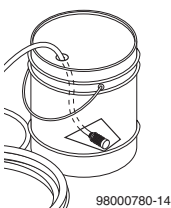

98000780-14

**STEP 2:** Use detergent designed specifically for pressure washers. Household detergents could damage the pump. Prepare detergent solution as required by the manufacturer. Fill a container with pressure washer detergent. Place the filter end of detergent suction tube into the

detergent container.

**STEP 3:** Apply safety latch to spray gun trigger. Turn variable pressure control handle until discharge water exits both tubes. Secure black detergent nozzle into quick coupler if you have a single wand. **NOTE:** Detergent cannot be applied using Red, Yellow, Green or White nozzles.

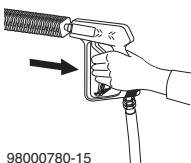

98000780-15

**STEP 4:** With the engine running, pull trigger to operate machine. Liquid detergent is drawn into the machine and mixed with water. Apply detergent to work area. Do not allow detergent to dry on surface.

## Thermal Pump Protection

If you run the engine on your pressure washer for 3-5 minutes without pressing the trigger on the spray gun, circulating water in the pump can reach high temperatures. When the water reaches this temperature, the pump protector engages and cools the pump by discharging the warm water onto the ground. This thermal device prevents internal damage to the pump.

## Cleaning Tips

Pre-rinse cleaning surface with fresh water. Place detergent suction tube directly into cleaning solution and apply to surface at low pressure (for best results, limit your work area to sections approximately 6 feet square and always apply detergent from bottom to top). Allow detergent to remain on surface 1-3 minutes. Do not allow detergent to dry on surface. If surface appears to be drying, simply wet down surface with fresh water. If needed, use brush to remove stubborn dirt. Rinse at high pressure from top to bottom in an even sweeping motion keeping the spray nozzle approximately 1 foot from cleaning surface. Use overlapping strokes as you clean and rinse any surface. For best surface cleaning action spray at a slight angle.

## Recommendations

- Before cleaning any surface, an inconspicuous area should be cleaned to test spray pattern and distance for maximum cleaning results.
- If painted surfaces are peeling or chipping, use extreme caution as pressure washer may remove the loose paint from the surface.
- Keep the spray nozzle a safe distance from the surface you plan to clean. High pressure wash a small area, then check the surface for damage. If no damage is found, continue to pressure washing.

### CAUTION - Never use:

- Bleach, chlorine and other corrosive chemicals
- Liquids containing solvents (i.e., paint thinner, gasoline, oils)
- Tri-sodium phosphate products
- Ammonia products
- Acid-based products

These chemicals will harm the machine and will damage the surface being cleaned.

## Rinsing

It will take a few seconds for the detergent to clear. Apply safety latch to spray gun. Remove black soap nozzle from the quick coupler. Select and install the desired high pressure nozzle. **NOTE:** You can also stop detergent from flowing by simply removing detergent siphon tube from bottle.

## Shutting Down And Clean-Up

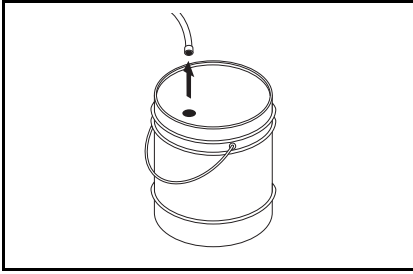

**STEP 1:** Remove detergent suction tube from container and insert into 1 gallon of fresh water. Turn variable pressure wand handle for low pressure or connect the black detergent nozzle. Pull trigger on spray gun and siphon water for one minute.

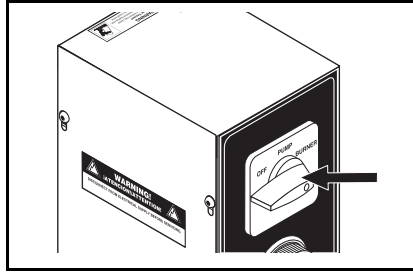

**STEP 2:** Turn burner switch off and continue spraying water, allowing the water to cool. After water has cooled to less than 100°F, turn the attached pressure washer off.

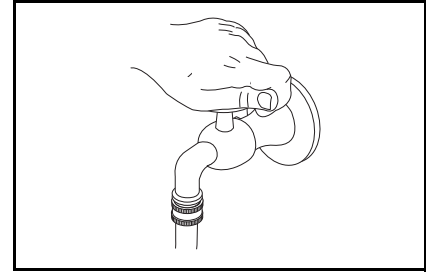

**STEP 3:** Turn off water supply.

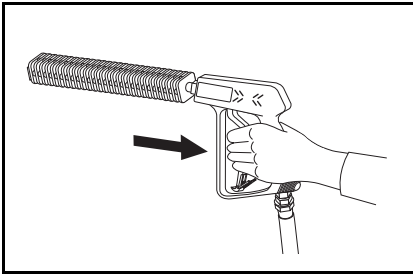

**STEP 4:** Turn garden hose water off. Open the spray gun to relieve remaining pressure.

## Storage

**CAUTION:** Always store your pressure washer in a location where the temperature will not fall below 32°F (0°C). The pump in this machine is susceptible to permanent damage if frozen. **FREEZE DAMAGE IS NOT COVERED BY WARRANTY.**

**Attention :** Toujours entreposer la laveuse à pression dans un endroit où la température ne sera pas inférieure à 0 °C (32 °F). La pompe sur cette machine est susceptible de subir des dommages si elle est exposée au gel. **LES DOMMAGES DUS AU GEL NE SONT PAS COUVERTS PAR LA GARANTIE.**

1. Stop the pressure washer, squeeze spray gun trigger to release pressure.
2. Detach water supply hose and high pressure hose.
3. Turn on the machine for a few seconds, until remaining water exits. Turn motor off immediately.
4. Drain the fuel from the fuel tank.
5. Do not allow high pressure hose to become kinked.
6. Store the machine and accessories in a room which does not reach freezing temperatures.

**CAUTION:** Failure to follow the above directions will result in damage to your pressure washer.

**Attention :** Le non-respect des directives ci-dessus entraînera des dommages à la laveuse à pression.

When the pressure washer is not being operated or is being stored for more than one month, follow these instructions:

1. Replenish pump oil to upper level.
2. Drain fuel from fuel tank, fuel line and filter.
3. Cover the pressure washer and store in a clean, dry place that is well ventilated away from open flame or sparks.

## After Extended Storage



**CAUTION:** Prior to restarting, thaw out any possible ice from pressure washer hoses, spray gun or wand.

**Attention :** Avant de redémarrer, faire fondre la glace se trouvant sur les boyaux, le pistolet pulvérisateur ou la lance de la laveuse à pression.

### Preventative Maintenance

1. Use clean fuel — kerosene, No. 1 home heating fuel or diesel fuel. Clean or replace fuel filter every 100 hours of operation. Avoid water contaminated fuel as it will seize up the fuel pump. De-soot coils monthly. Use an additive if diesel is being used.
2. Check to see that the attached pressure washer water pump is properly lubricated.
3. Follow winterizing instructions to prevent freeze damage to pump and coils.
4. Always neutralize and flush detergent from system after use.
5. If water is known to be high in mineral content, use a water softener on your water system, or de-scale as needed.
6. Do not allow acidic, caustic or abrasive fluids to be pumped through the system.
7. Always use high grade quality cleaning products.
8. Never run attached pressure washer pump dry for extended periods of time.
9. If machine is operated with smoky or eye burning exhaust, coils will soot up, preventing water from reaching maximum operating temperature. (See section on Maintenance and Service).
10. Never allow water to be sprayed on or near the motor or burner assembly or any electrical component.
11. Descale coils as per instructions.

It is advisable, periodically, to visually inspect the burner. Check air inlet to make sure it is not clogged or blocked. Wipe off any oil spills and keep equipment clean and dry.

The areas around the pressure washer should be kept clean and free of combustible materials, gasoline and other flammable vapors and liquids.

The flow of ventilating air to the burner must not be blocked or obstructed in any manner.

### Maintenance And Service

#### Unloader Valves

Unloader valves trap pressure in the line when a shut-off spray gun is closed. Machines with unloader valves are preset and tested at the factory before shipping. Tampering with the factory settings may cause personal injury and/or property damage and will void the manufacturer's warranty.

#### Winterizing Procedure

Damage due to freezing is not covered by warranty. Adhere to the following cold weather procedures whenever the washer must be stored or operated outdoors under freezing conditions.

During winter months, when temperatures drop below 32°F, protecting your machine against freezing is necessary. Store the machine in a heated room. If this is not possible then mix a 50/50 solution of anti-freeze/water or windshield washer fluid with water in a 5 gallon bucket. Place a short section of garden hose into the bucket and connect it to the machine. Elevate the bucket and turn the pump on to siphon the anti-freeze through the machine. If compressed air is available, an air fitting can be screwed into the inlet connector and by injecting compressed air, all water will be blown out of the system.

If you have an optional float tank, pour the antifreeze into this tank and run machine until antifreeze exits discharge nipple.

#### High Limit Hot Water Thermostat

For safety, each machine is equipped with a high limit control switch. In the event the temperature of the water should exceed its operating temperature, the high limit control will turn the burner off until the water cools.

#### Pumps

Use only SAE 10W-40 weight non-foaming oil. Change oil after first 50 hours of use. Thereafter, change oil every year or at 500 hour intervals. Oil level should be checked by using the dipstick found on the top of the pump or by the red dot visible through the oil gauge window. Oil should be maintained at that level.



## Cleaning of Coils

In alkaline water areas, lime deposits can accumulate rapidly inside the coil pipes. This growth is increased by the extreme heat build up in the coil. The best prevention for liming conditions is to use high quality cleaning detergents. In areas where alkaline water is an extreme problem, periodic use of Karcher Coil Descaler (part # 9.803-742.0) will remove lime and other deposits before coil becomes plugged.

Periodic descaling of the heating coil is recommended so please consult your local Karcher Dealer for instructions

## Removal of Soot In Heating Coil

In the heating process, fuel residue in the form of soot deposits may develop between the heating coil pipe and block air flow which will affect burner combustion. When soot has been detected on visual observation, the soot on the coil must be washed off after coil has been removed using the following steps:

1. Remove the tank head assembly by unscrewing the three tek screws and lifting the tank head off.
2. Remove the two pipe nipples and associated fittings.
3. Lift the coil out of the outer wrap.

**CAUTION: The coil weighs about 80 lbs. Use proper lifting techniques.**

**Attention : La bobine pèse environ 36.25kg (80 lb). Utiliser des techniques de levage appropriées.**

4. Clean, repair and replace the coil by reversing the above steps.

## Coil Re-installation

Reinstall by reversing the above steps 4 through 1.

## Rupture Disk

If pressure from pump or thermal expansion should exceed safe limits, the rupture disk will burst, allowing high pressure to be discharged through hose to ground. When the disk ruptures, it will need to be replaced.

## Fuel

Use clean fuel oil that is not contaminated with water and debris. Replace fuel filter and drain tank every 100 hours of operation. Use Kerosene No. 1 or No. 2 Heating Fuel (ASTM D306) or diesel only. **NEVER** use gasoline in your burner tank. Gasoline is more combustible than fuel oil and could result in a serious explosion. **NEVER** use crankcase or waste oil in your burner. Fuel unit malfunction could result from contamination.

## Ignition Circuit

Periodically inspect wires, spring contact and electrodes for condition, security and proper spacing. **For transformer test (CAUTION 10,000 VOLTS)** use defect free insulated screwdriver and keep fingers off blade! Lay blade across one contact: OK if arc will span 1/2" between end of blade and other contact.

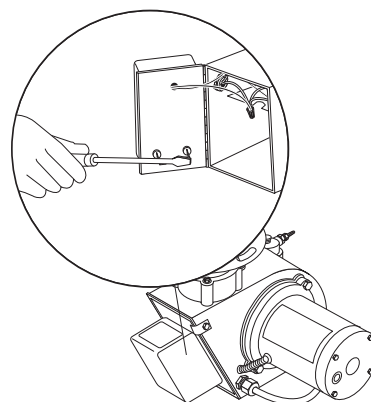

## Electrode Setting

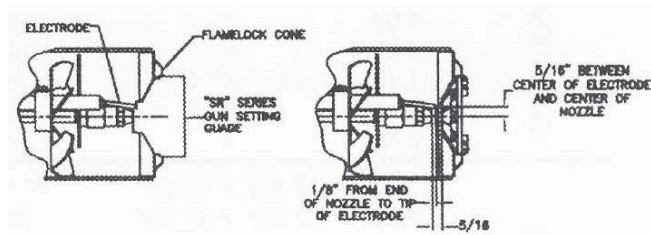

SR-Series Gage

KNA Part Number: 8.717-379.0

## Burner Nozzle

Keep the tip free of surface deposits by wiping it with a clean, solvent-saturated cloth, being careful not to plug or enlarge the nozzle. For maximum efficiency, replace the nozzle each season.

## Fuel Control System

This machine utilizes a fuel solenoid valve located on the fuel pump to control the flow of fuel to the combustion chamber. This solenoid is activated by a pressure switch located on the unloader valve. When an operator releases the trigger on the spray gun, the pressure drops, allowing the pressure switch to activate the fuel solenoid. The solenoid then closes, shutting off the supply of fuel to the combustion chamber. Controlling the flow of fuel in this way gives an instantaneous burn or no burn situation, thereby eliminating high and low water temperatures, and combustion smoke normally associated with machines incorporating a spray gun. Periodic inspection is recommended to insure that the fuel solenoid valve functions properly. This can be done by operating the machine and checking to see that when the trigger on the spray gun is in the off position, the burner is not firing.

## Fuel Pressure Adjustment

To adjust fuel pressure, First install a pressure gage into the port just after the pump fuel exit. Turn the adjusting screw (located at the regulator port) clockwise to increase, and counterclockwise to decrease. Do not exceed 200 psi or lower the pressure below 130 PSI, when checked at the post-pump pressure port.

The fuel pressure may need to be adjusted due to altitude. For every 500 ft altitude above sea level, the boiling point of water goes down 1 °F. At high altitude environments, this boiling point change may require the heat input to be lowered so the water input does not turn to steam earlier than at the factory settings and activate the pressure sensors and pressure relief equipment when the unit is operated and much higher altitudes from factory settings or local dealer site settings. Check with your dealer before making local site fuel pressure adjustments.

Also, as ambient temperature changes seasonally, the fuel temperature in the feed tank and air temperature inlet can impact fuel flow. In more extreme temperatures, this local-site adjustment may also require different fuel nozzles for fuel inlet temperatures that are at seasonal extremes (higher or lower) in locations where the temperature changes are beyond moderate temperatures of between 40°F and 90°F. Colder temperatures will make for a thicker flow and less fine a fuel spray while hotter temperatures will make for a thinner flow a more fine spray with the same nozzle. Consider alternate nozzle configurations from the baseline factory-supplied nozzle for operating in such temperature extremes if performance is not meeting needs with air band and fuel pressure settings alone.

*NOTE: When changing fuel pump, a by-pass plug must be installed in return line port or fuel pump will not prime.*

## Oil Burner

**Burner Air Adjustment:** The oil burner on this machine is preset for operation at altitudes below 500 feet. If operated at higher altitudes, it may be necessary to adjust the air band for a #1 or #2 smoke spot on the Bacharach scale.

To adjust, start machine and turn burner ON. Loosen two locking screws found on the air band and close air band until black smoke appears from burner exhaust vent. Note air band position. Next, slowly open the air band until white smoke just starts to appear. Turn air band halfway back to the previously noted position. Tighten locking screws.

For higher altitudes, the air band opening may need to be increased; for lower altitude, the air band may need to be decreased.

For higher humidity, the air band opening may need to be increased; for lower relative humidity, the air band may need to be decreased.

For higher ambient temperatures the air band opening may need to be increased; for lower ambient temperatures, the air band opening may need to be decreased.

Adjust to your operating location's environment as-needed for best smoke spot and performance compliant with local, state, and federal regulations.

**CAUTION:** If white smoke appears from burner exhaust vent during start-up or operation, discontinue use and readjust air bands.

*NOTE: If a flue is installed, have a professional serviceman adjust your burner for a #1 or #2 smoke spot on the Bacharach scale.*

**Maintenance Charts**

This pressure washer was produced with the best available materials and quality craftsmanship. However, you as the owner have certain responsibilities for the correct care of the equipment. Attention to regular preventative maintenance procedures will

assist in preserving the performance of your equipment. Contact your Pressure Washers dealer for maintenance. Regular preventative maintenance will add many hours to the life of your pressure washer. Perform maintenance more often under severe conditions.

<b>MAINTENANCE SCHEDULE</b>		
Replace Fuel Lines		Annually
Pump Oil (non-foaming SAE 10W-40)	Inspect	Daily inspect the oil level
	Change	After first 50 hours, then every 500 hours or annually
Clean Burner Filter		Monthly (More often if fuel quality is poor)
Remove Burner Soot		Annually
Burner Adjustment/Cleaning		Annually
De-scale Coil		Annually (More often if required)
Replace High Pressure Nozzle		Every 6 months
Replace Quick Connects		Annually
Clean Water Screen/Filter		Weekly
Clean Float/Supply Tank		Every 6 months
Replace HP Hose		Annually if there is any sign of wear
Grease Motor		Every 10,000 hours
Replace Burner Nozzle		Annually

**Oil Change Record**

<b>Date Oil Changed Month/Day/Year</b>	<b>Estimated Operating Hours Since Last Oil Change</b>

<b>Date Oil Changed Month/Day/Year</b>	<b>Estimated Operating Hours Since Last Oil Change</b>

## Troubleshooting

PROBLEM	POSSIBLE CAUSE	SOLUTION
<b>LOW OPERATING PRESSURE</b>	Faulty pressure gauge	Install new gauge.
	Insufficient water supply	Use larger garden hose; clean filter washer at water inlet.
	Old, worn or incorrect spray nozzle	Match nozzle number to machine and/or replace with new nozzle.
	Plumbing or hose leak	Check plumbing system for leaks. Retape leaks with teflon tape.
	Faulty or mis-adjusted unloader valve (where applicable)	Adjust unloader for proper pressure. Install repair kit when needed.
	Worn packing in pump	Install new packing kit.
	Fouled or dirty inlet or discharge valves in pump	Clean inlet or discharge valves.
	Worn inlet or discharge valves	Replace with valve kit.
<b>DETERGENT NOT DRAWING</b>	Air leak	Tighten all clamps. Check detergent lines for holes.
	Valve in the injector head may be blocked, dirty or damaged	Clean or replace valve in injector.
	Filler screen on detergent suction hose plugged	Clean or replace.
	Dried up detergent plugging metering valve	Disassemble and clean thoroughly.
	High viscosity of detergent	Dilute detergent to specifications.
	Hole in detergent line(s)	Repair hole.
	Low detergent level	Add detergent if needed.
	Discharge water temperature above 180°F	Lower discharge water temperature.
<b>PUMP RUNNING NORMALLY BUT PRESSURE LOW ON INSTALLATION</b>	Pump sucking air	Check water supply and possibility of air seepage.
	Valves sticking	Check and clean or replace if necessary.
	Unloader valve seat faulty	Check and replace if necessary.
	Nozzle incorrectly sized	Check and replace if necessary (See serial plate for proper size).
	Worn piston packing	Check and replace in necessary.
<b>FLUCTUATING PRESSURE</b>	Valves worn	Check and replace if necessary.
	Blockage in valve	Check and replace if necessary.
	Pump sucking air	Check water supply and air seepage at joints in suction line.
	Worn piston packing	Check and replace if necessary.
<b>PUMP NOISY</b>	Air in suction line	Check water supply and connections on suction line.
	Broken or weak inlet or discharge valve springs	Check and replace if necessary.
	Excessive matter in valves	Check and clean if necessary.
	Worn bearings	Check and replace if necessary.

Troubleshooting

PROBLEM	POSSIBLE CAUSE	SOLUTION
<b>LOW WATER TEMPERATURE</b>	Improper fuel or water in fuel	Drain fuel tank and replace with proper fuel.
	Low fuel pressure	Increase fuel pressure.
	Weak fuel pump	Check fuel pump temperature. Replace pump if needed.
	Fuel filter partially clogged	Replace as needed.
	Soot build up on coils	Clean coils with soot remover.
	Lime build up on coils	Clean inside of coils using coil cleaner.
	Improper burner nozzle	See Burner Specifications.
<b>WATER TEMPERATURE TOO HOT</b>	Incoming water to machine warm or hot	Lower incoming water temperature.
	Fuel pump pressure too high	Lower fuel pressure.
	Fuel pump defective	Replace fuel pump.
	Detergent line sucking air	Tighten all clamps. Check detergent line for holes.
	Defective high limit switch (thermostat)	Replace.
	Incorrect fuel nozzle size	See Burner Specifications.
	Insufficient water supplied	Check GPM to machine.
	Restricted water flow	Check nozzle for obstruction, proper size.
<b>MACHINE SMOKES WHILE BURNER UNIT IS RUNNING OR UNIT SMOKES AT COLD-START ONLY WHEN BURNER IS OFF</b>	Improper air adjustment	Readjust air bands on burner assembly
	Fuel pressure is low <140 psi for burner	Adjust fuel pump pressure to specifications
	Burner nozzle is plugged or dirty	Replace nozzle. Check parts breakdown for nozzle size
	Burner nozzle spray pattern is faulty	Replace nozzle. Check parts breakdown for nozzle size
	Heavy accumulation of soot on coils and burner assembly	Remove coils and burner assembly, clean thoroughly. Call local dealer
	Misaligned electrode setting	Realign electrodes to specifications
	Obstruction in smoke stack	Check for insulation blockage or other foreign objects
	Low engine RPM	Increase RPM to correct specs. See serial plate
	Fuel Pressure is too high for clean burn (fuel PSI above 140 and below 200) and smokes when burner is off	Reduce fuel pressure PSI/Increase air band set for cleaner without max water heat loss







# Parts

## KARCHER HDS

**HDS 3.9/20 Ea Cage**  
**1.575-505.0**

**HDS 3.5/30 Ea Cage**  
**1.575-508.0**

**HDS 3.5/30 Eb Cage**  
**1.575-509.0**

**HDS 3.5/30 Ec Cage**  
**1.575-510.0**

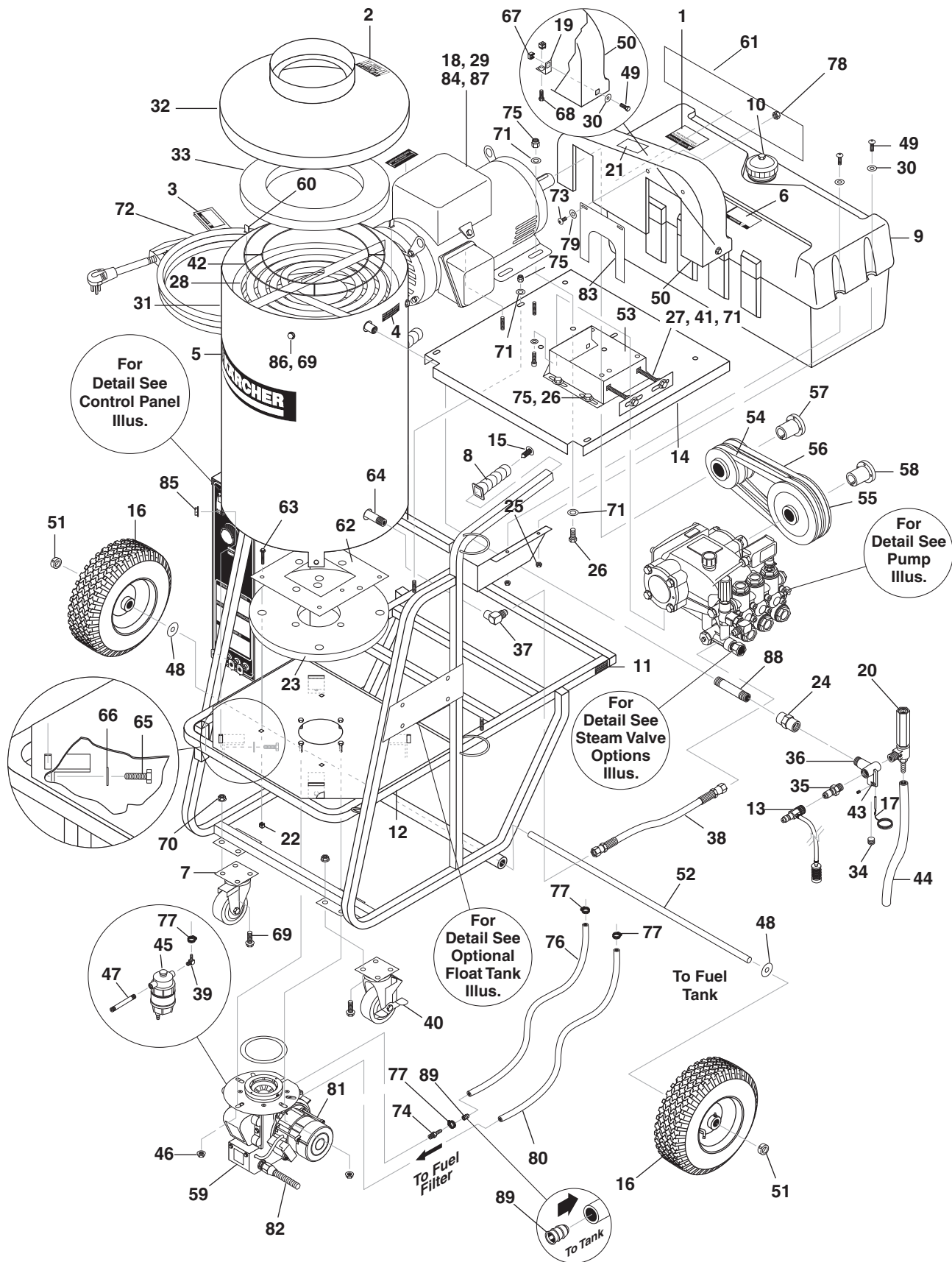

REF	PART NO.	QTY	DESCRIPTION	NOTES
1	9.800-002.0	1	LABEL, USE ONLY KEROSENE	
2	9.800-006.0	1	LABEL, "HOT/CALIENTE" WITH ARROWS WARNING	
3	8.932-969.0	1	LABEL, WARNING, SERVICE CORD	
4	9.800-021.0	1	LABEL, HOT WATER OUTLET	
5	9.800-110.0	1	LABEL, LOGO LARGE	
6	9.800-035.0	1	LABEL, WARNING (LEXAN)	
7	9.802-272.0	1	WHEEL, 5" CASTER	
8	9.802-070.0	2	GRIP, 1" SQUARE, HANDLE	
9	8.706-612.0	1	TANK, FUEL, 9 GALLON POLY, BLACK	
10	9.802-089.0	1	CAP, FUEL TANK, PLASTIC H60-AV	
11	9.800-020.0	1	LABEL, COLD WATER INLET	
12	8.920-491.0	1	FRAME ASSY, HPB, KARCHER	
13	9.802-225.0	1	DOWNSTREAM INJECTOR ASSEMBLY, NON ADJ. #3	
14	9.803-064.0	1	POWER PLATFORM	(505.0)
	9.803-063.0	1	POWER PLATFORM	(508.0, 509.0, 510.0)
15	9.802-107.0	2	FASTENER, RATCHET, BLACK NYLON	
16	8.754-435.0	2	WHEEL & PU TIRE ASSY, 12" STEEL RIM	
17	8.750-094.0	1	THERMOSTAT, 302°	
18	-	-	FOR MOTOR	SEE SPECIFICATIONS PAGES
19	9.802-872.0	3	TAB, BELT GUARD MOUNT	
20	8.902-433.0	1	VALVE, SAFETY RELIEF	
21	8.932-965.0	1	LABEL, WARNING, EXPOSED PULLEY	
22	9.802-792.0	4	NUT, CAGE, 3/8" X 12 GAUGE	
23	9.802-905.0	1	INSULATION BLANKET, 18" OD X 4.5" ID	
24	8.706-141.0	1	COUPLING, 1/2" STEEL PIPE	
25	9.802-775.0	4	NUT, 1/4", FLANGE	
26	9.802-720.0	8	BOLT, 3/8" X 1"	(508.0, 509.0, 510.0)
-	-	6	BOLT, 3/8" X 1" -	(505)
27	9.802-733.0	2	BOLT, 3/8" X 3-1/2", TAP	
28	9.802-995.0	1	COIL, 18"	
-	9.802-896.0	1	INSULATION BLANKET	NOT SHOWN
29	9.802-518.0	1	STRAIN RELIEF, 3/4"	NOT SHOWN (505.0)
-	9.803-279.0	1	STRAIN RELIEF, 1"	NOT SHOWN (508.0, 509.0, 510.0)
30	9.802-803.0	4	WASHER, 1/4"	
31	8.933-031.0	1	OUTER WRAP, 18" COIL S.S.	
32	9.802-973.0	1	TANK END 18"	
33	8.717-442.0	1	INSULATION DISK	
34	8.706-248.0	1	PLUG, 3/8"	

REF	PART NO.	QTY	DESCRIPTION	NOTES
35	9.802-171.0	1	NIPPLE, 3/8" X 3/8" NPT STREET MALE	
36	9.149-003.0	1	MANIFOLD COIL DISCHARGE	
37	9.802-043.0	1	ELBOW, 1/2" JIC X 1/2" FEMALE	
38	8.918-423.0	1	HOSE, 3/8" X 22"	
39	8.706-958.0	1	HOSE BARB, 1/4" BARB, 1/4" PIPE, 90°	
40	9.802-273.0	1	WHEEL, 5" CASTER, W/BRAKE	
41	9.802-789.0	2	NUT, 3/8" HEX	
42	8.719-935.0	1	RETAINER RING, INSULATION	
43	9.196-012.0	1	SCREW, 10-24 X 1/4"	
44	8.711-785.0	30"	HOSE, 3/8" PUSH-ON	
45	8.725-306.0	1	FILTER, FUEL/H2O	
46	9.802-781.0	4	NUT, 3/8" FLANGE, WHIZ LOC	
47	9.803-264.0	1	NIPPLE, 1/4" X 3", BLACK PIPE	
48	9.802-810.0	2	WASHER, 5/8" FLAT	
49	9.802-770.0	7	SCREW, 1/4" X 1"	
50	9.802-094.0	1	BELT GUARD	
51	9.802-782.0	2	COLLAR, 5/8"	
52	9.803-066.0	1	AXLE, SR	
53	9.803-131.0	1	PUMP RAIL, BLACK	
54	-	-	PULLEY	SEE SPECIFICATIONS PAGES
55	-	-	PULLEY	SEE SPECIFICATIONS PAGES
56	-	-	BELT	SEE SPECIFICATIONS PAGES
57	-	-	BUSHING	SEE SPECIFICATIONS PAGES
58	9.802-402.0	1	BUSHING, 24MM	
59	-	-	BURNER	SEE SPECIFICATIONS PAGES
60	9.802-825.0	4	CLIP, RETAINER	
61	8.932-985.0	1	LABEL, KARCHER STRIPE	
62	9.803-030.0	1	RETAINER, BURNER INSULATION	
63	9.802-768.0	4	SCREW, 3/8" X 1-1/4" WHIZ LOC	
64	9.802-014.0	1	NIPPLE, 1/2" X 3", GALVANIZED	
65	8.718-618.0	1	BOLT, 5/16" X 3/4"	
66	8.718-980.0	4	WASHER, 5/16 FLAT	
67	9.802-794.0	6	NUT, CAGE, 1/4" X 12 GAUGE	
68	9.802-754.0	3	SCREW, 1/4" X 1/2", WHIZ LOC	
69	9.802-752.0	8	SCREW, 1/4" X 1-1/4", WHIZ LOC	
70	8.718-817.0	4	NUT, 1/4-20 WHIZ LOC	
71	9.802-807.0	23	WASHER, 3/8", FLAT	(505.0)
-	-	21	WASHER, 3/8", FLAT -	(508.0, 509.0, 510.0)
72	9.802-430.0	1	GFCI, 230V, 30 AMP	(505.0)
-	9.802-434.0	1	GFCI, 240V, 40 AMP	(508.0)
-	9.802-437.0	15 ft	SERVICE CORD, 10/4	(509.0)
-	9.802-429.0	15 ft	SERVICE CORD, 12/4	(510.0)

REF	PART NO.	QTY	DESCRIPTION	NOTES
73	9.802-765.0	2	SCREW, 1/4-20 X 1/2" BH, SOC	
74	8.706-941.0	1	HOSE BARB, 1/4"	
75	9.802-779.0	11	NUT, 3/8" ESNA	
76	9.802-254.0	28"	FUEL LINE, 1/4"	
77	8.706-069.0	4	CLAMP, SCREW 5/16"W, 1/4-5/8" D, SS	
78	9.802-775.0	2	NUT, 1/4", ESNA, NC, SS	
79	9.804-082.0	2	WASHER, 1/4" FLAT, ZINC	
80	9.802-254.0	27"	FUEL LINE, 1/4"	
81	9.802-448.0	2.25 ft.	CONDUIT, WATER TITE	
82	9.802-517.0	1	CONNECTOR 1/2" L/T 90° BLACK	
83	8.920-445.0	1	ADAPTER PLATE, PUMP	
84	9.802-436.0	41"	CORD SERVICE 10-3	NOT SHOWN (505.0)
-	9.802-437.0	41"	CORD SERVICE 10-4	NOT SHOWN (509.0)
-	9.802-425.0	41"	CORD SERVICE 8-3	NOT SHOWN (508.0)
85	9.802-778.0	4	NUT, WHIZ 5/16 FLANGE	
86	9.802-793.0	4	NUT, CAGE 1/4" X 16 GAUGE	
87	9.803-280.0	1	LOCK NUT 1"	NOT SHOWN (508.0, 509.0, 510.0)
88	9.802-013.0	1	NIPPLE, 1/2" X 2-1/2"	
89	8.754-911.0	1	CHECK VALVE, 1 WAY, 1/4" BARB	

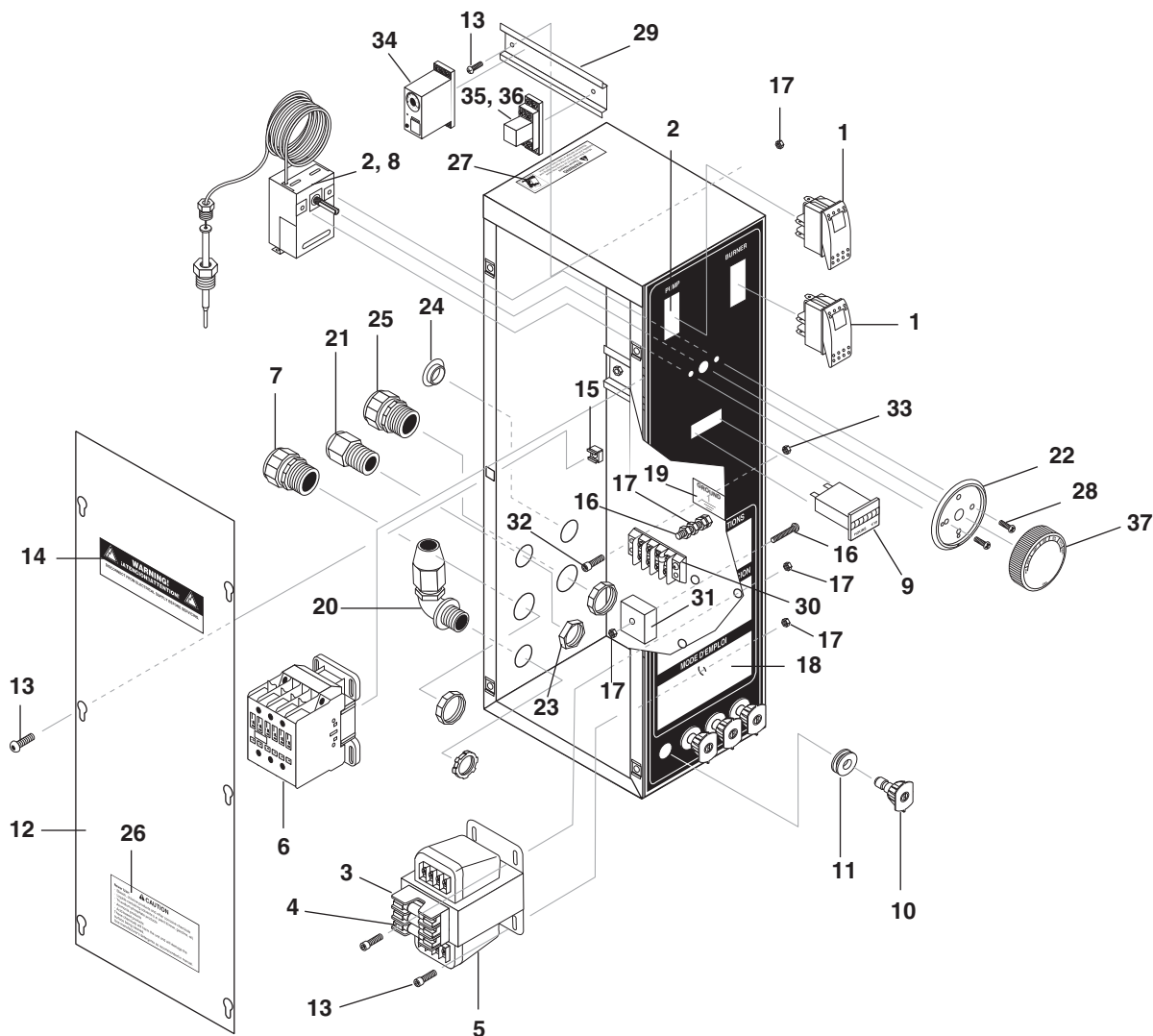

REF	PART NO.	QTY	DESCRIPTION	NOTES
1	9.802-451.0	2	SWITCH, ROCKER, CARLING W/GREEN LENS	
-	-	1	-	(TIME DELAY OPTION)
-	9.802-452.0	1	ROCKER SWITCH, RED LENS	(TIME DELAY OPTION)
2	9.802-447.0	48"	CONDUIT, 1/4" SPLIT	NOT SHOWN
3	-	-	FUSE	SEE SPECIFICATIONS PAGES
4	-	-	FUSE	SEE SPECIFICATIONS PAGES
5	-	-	TRANSFORMER	SEE SPECIFICATIONS PAGES
6	-	-	CONTACTOR	SEE SPECIFICATIONS PAGES
7	9.802-518.0	1	STRAIN RELIEF, STRAIGHT, L/T	(ALL MODELS EXCEPT 508.0)
-	9.802-521.0	1	STRAIN RELIEF, 3/4" WATERTIGHT	(508.0)
8	8.750-095.0	1	THERMOSTAT, 302°	
9	9.802-283.0	1	HOUR METER	(OPTIONAL)

REF	PART NO.	QTY	DESCRIPTION	NOTES
10	8.712-357.0	1	NOZZLE, SAQCMEG 0055, RED	(505.0)
-	8.712-358.0	1	NOZZLE, SAQCMEG 1505.5, YELLOW	(505.0)
-	8.712-359.0	1	NOZZLE, SAQCMEG 2505.5, GREEN	(505.0)
-	8.712-360.0	1	NOZZLE, SAQCMEG 4005.5, WHITE	(505.0)
-	8.712-345.0	1	NOZZLE, SAQCMEG 0004, RED	(508.0, 509.0, 510.0)
-	8.712-346.0	1	NOZZLE SAQCMEG 1504, YELLOW	(508.0, 509.0, 510.0)
-	8.712-347.0	1	NOZZLE, SAQCMEG 2504, GREEN	(508.0, 509.0, 510.0)
-	8.712-348.0	1	NOZZLE, SAQCMEG 4004, WHITE	(508.0, 509.0, 510.0)
11	9.802-064.0	4	GROMMET, RUBBER, NOZZLE HOLDER	
12	9.802-880.0	1	COVER, ELECTRICAL BOX	
13	9.802-759.0	13	SCREW, 10/32" X 1/2"	
-	-	2	SCREW, 10/32" X 1/2"	(TIME DELAY OPTION)
14	9.800-016.0	1	LABEL, DISCONNECT POWER SUPPLY	
15	9.802-791.0	6	NUT, CAGE, 10/32" X 16 GAUGE	
16	9.802-762.0	1	SCREW, 10/32" X 1-1/4"	
-	-	1	SCREW, 10/32" X 1-1/4"	(AUTO START/STOP OPTION)
17	9.802-695.0	4	NUT, 10/32" KEPS	
-	-	1	NUT, 10/32" KEPS	(AUTO START/STOP DELAY OPTION)
-	-	2	NUT, 10/32" KEPS	(TIME DELAY OPTION)
18	9.800-112.0	1	LABEL, CONTROL PANEL	
19	9.800-040.0	1	LABEL, GROUND	
20	9.802-517.0	1	CONNECTOR, 1/2", L/T 90°, BLACK	
21	9.802-514.0	1	STRAIN RELIEF, STRAIGHT, L/T, SMALL	
22	8.712-190.0	1	BEZEL, PLASTIC	
23	9.802-525.0	1	LOCKNUT, 1/2"	
24	9.802-103.0	1	BUSHING, SNAP, 5/8"	
25	9.802-518.0	1	STRAIN RELIEF, STRAIGHT, L/T, LARGE	
26	9.800-018.0	1	LABEL, TIPOVER HAZARD	
27	9.800-049.0	1	LABEL, CLEANING SOLUTION	
28	9.196.012.0	2	SCREW, 10/24 X 1/4" HEX	
29	9.802-457.0	4"	DIN RAIL	
-	-	2"	DIN RAIL	(TIME DELAY OPTION)
30	9.802-491.0	1	BLOCK TERMINAL 4 POLE	(AUTO START/STOP, TIME DELAY OPTION)
31	9.802-472.0	1	TIMER SOLID STATE 120V, 5-60, MINUTE ADJ.	(AUTO START/STOP OPTION)
32	9.802-749.0	2	SCREW 8/32" X 3/4"	(AUTO START/STOP, TIME DELAY OPTION)
33	9.802-785.0	2	NUT 8/32" KEPS	(AUTO START/STOP, TIME DELAY OPTION)
34	8.751-306.0	1	TIMER, MULTI FUNCTION 24V- 120/240V	(TIME DELAY OPTION)
35	9.802-467.0	1	BASE RELAY	(TIME DELAY OPTION)
36	9.802-468.0	1	RELAY 120V	(TIME DELAY OPTION)
37	8.750-096.0	1	KNOB, THEMOSTAT 302°F	

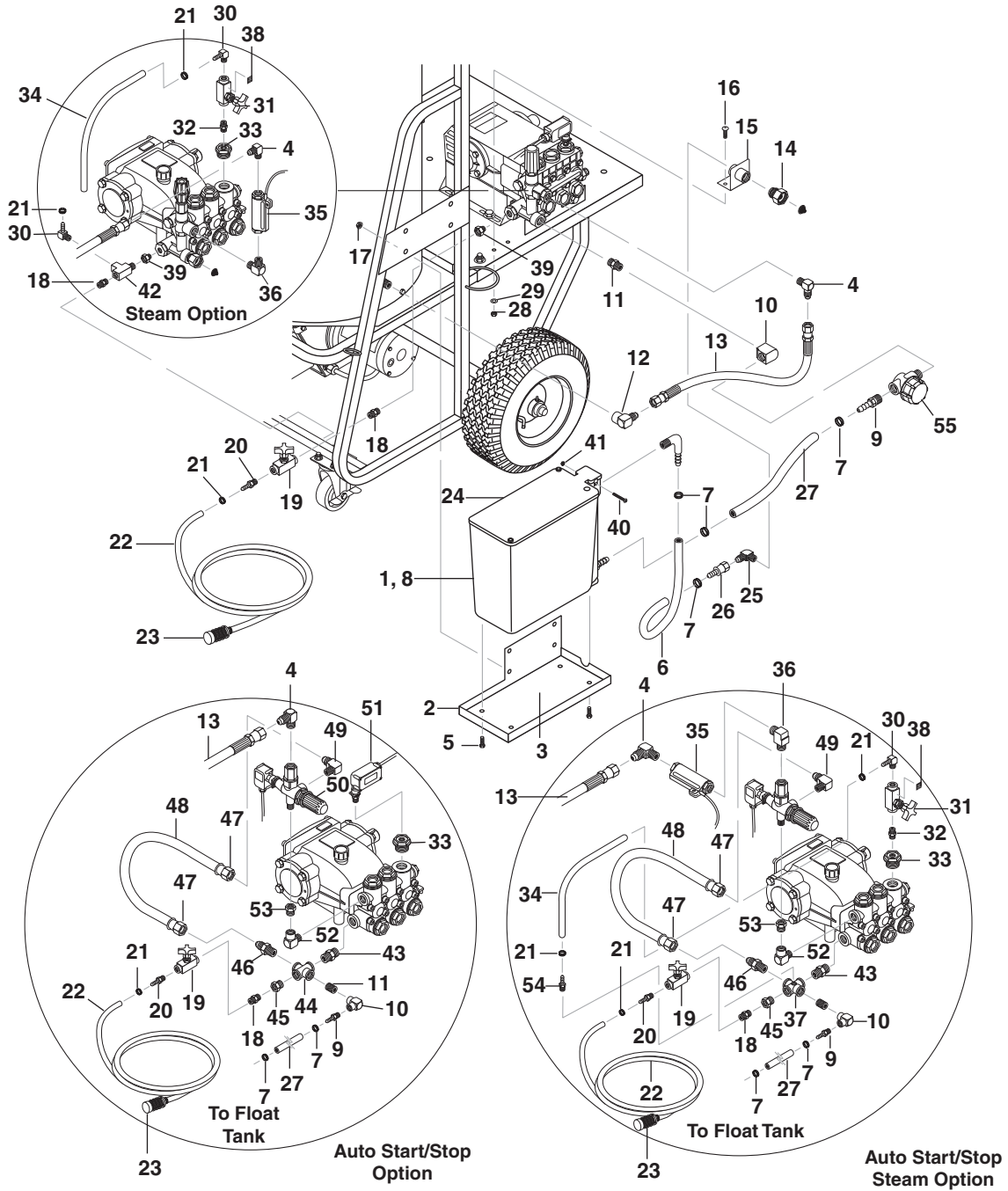



REF	PART NO.	QTY	DESCRIPTION	NOTES
1	8.706-645.0	1	TANK, FLOAT	
2	9.803-269.0	1	SHELF, FLOAT TANK, BLACK	
3	9.802-767.0	4	SCREW, 3/8" X 3/4" HH NC, WHIZ LOC	
4	9.802-039.0	1	ELBOW, 1/2" JIC X 3/8" FEMALE, 90°	
5	9.803-277.0	4	SCREW, 5/16" X 1/2" WHIZ LOC	
6	9.802-260.0	20"	HOSE, 5/8", PUSH-ON	
7	9.802-201.0	4	CLAMP, SCREW, #6	
8	8.932-994.0	1	VALVE, FLOAT	NOT SHOWN
-	9.802-062.0	1	BALL FLOAT	NOT SHOWN
9	8.706-943.0	1	HOSE BARB, 5/8" BARB X 1/2" ML PIPE	
10	8.706-820.0	1	ELBOW, 1/2" FEMALE, BRASS	
11	9.802-111.0	1	NIPPLE, 1/2" NPT, 5/16", MODIFIED CLOSE	
12	9.802-043.0	1	ELBOW, 1/2" X 1/2" FEMALE, 90°1	
13	8.918-423.0	1	HOSE, 3/8" X 22", 2 WIRE, PRESSURE LOOP	
14	9.802-146.0	1	SWIVEL, 1/2" MP X 3/4" GHF W/STRAINER	
15	9.802-961.0	1	HOSE CONNECTION BRACKET	
16	9.802-700.0	2	BOLT, 1/4" X 3/4", NC HH	
17	9.802-781.0	4	NUT, 3/8", FLANGE, WHIZ LOC, NC	
18	8.706-780.0	1	NIPPLE, 1/4" HEX	
19	8.707-317.0	1	VALVE, FLOW CONTROL	
20	8.706-941.0	1	HOSE BARB, 1/4" BARB X 1/4" ML PIPE	
21	6.390-126.0	1	CLAMP, HOSE, .46-, .54 ST	
-	-	3	CLAMP, HOSE, .46-, .54 ST	(FLOAT TANK W/STEAM)
22	9.802-251.0	72"	TUBE, 1/4" X 1/2", CLEAR VINYL	
23	8.707-058.0	1	STRAINER, 1/4" BRASS W/CHECK VALVE	
24	9.802-087.0	1	COVER, FLOAT TANK, PORTOTENICA	
25	9.802-131.0	1	ELBOW, 1/2" JIC X 1/2", 90°	
26	9.802-151.0	1	SWIVEL, 1/2" JIC FEMALE, PUSH-ON	
27	9.802-260.0	7"	HOSE, 5/8" PUSH-ON	
28	9.802-773.0	2	NUT, 1/4", ESNA, NC	
29	9.802-802.0	4	WASHER, 1/4" FLAT, SAE	
30	8.706-958.0	1	HOSE BARB, 1/4" BARB X 1/4" PIPE, 90°	
31	9.802-187.0	1	VALVE, FLOW CONTROL W/METERING	
32	8.705-973.0	1	NIPPLE, 1/4" HEX STEEL	
33	9.802-632.0		CAP, VALVE W/ 1/4" GAUGE PORT	
34	9.802-254.0	1	HOSE, 1/4", PUSH-ON	
35	8.933-006.0	14"	SWITCH, MV60 FLOW	
36	8.706-168.0	1	ELBOW, 3/8" MALE PIPE	
37	9.804-555.0	1	CROSS, 1/2" FEMALE W/ 1/8" NPT HOLE	
38	9.800-026.0	1	LABEL, OPEN FOR STEAM	
39	8.706-997.0	1	ADAPTER, 1/4" X 1/8"	
40	9.804-554.0	1	SCREW, 10/32" X 2-1/2"	

REF	PART NO.	QTY	DESCRIPTION	NOTES
41	9.802-695.0	1	NUT, 10/32" KEPS	
42	8.706-858.0	1	TEE, 1/4" STREET	
43	8.706-797.0	1	NIPPLE, 1/2" HEX	
44	9.802-119.0	1	CROSS, 1/2" FEMALE	
45	8.706-915.0	1	BUSHING, 1/2" X 1/4"	
46	9.802-128.0	1	NIPPLE, 1/2" JIC X 1/2" PIPE	
47	9.802-151.0	2	SWIVEL, 1/2" JIC FEMALE, PUSH-ON	
48	9.802-259.0	16"	HOSE, 1/2", PUSH-ON	
49	9.802-129.0	1	ELBOW, 1/2" JIC X 3/8" 90°	
50	9.802-362.0	1	UNLOADER VB8 W/SWITCH	
51	9.802-458.0	1	SWITCH, PRESSURE N/O 1/4", NPT SS	
52	8.706-207.0	1	ELBOW, 3/8" STREET	
53	8.706-309.0	1	ADAPTER, 3/8" X 3/8" STREET	
54	8.706-940.0	1	HOSE BARB, 1/4" BARB X 1/8" ML PIPE	
55	9.802-163.0	1	FILTER, 1/2" MPT, PA	

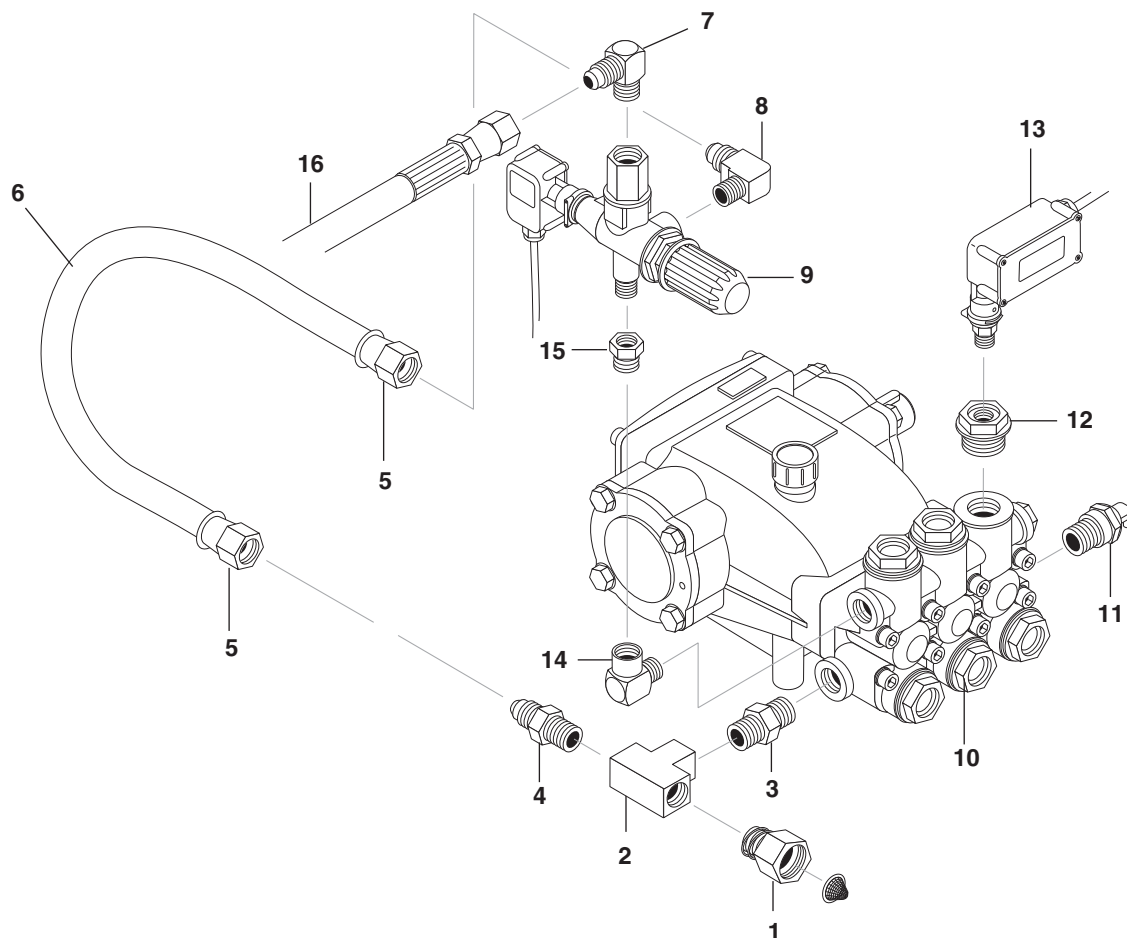

REF	PART NO.	QTY	DESCRIPTION	NOTES
1	9.802-146.0	1	SWIVEL, 1/2" MP X 3/4" GHF W/STRAINER	
2	8.706-844.0	1	TEE, 1/2" FEMALE PIPE	
3	8.706-797.0	1	NIPPLE, 1/2" HEX	
4	9.802-127.0	1	NIPPLE, 1/2" JIC X 1/2" MPT PIPE	
5	9.802-151.0	2	SWIVEL, 1/2" JIC FEM, PUSH-ON	
6	9.802-259.0	16"	HOSE, 1/2" PUSH-ON	
7	9.802-039.0	1	ELBOW, 1/2" JIC, 3/8"	
8	9.802-129.0	1	ELBOW, 1/2" JIC X 3/8"	
9	9.802-362.0	1	UNLOADER, VB8 W/SWITCH	
10	-		PUMP	SEE SPECIFICATIONS PAGES
11	8.707-256.0	1	PUMP PROTECTOR, 1/2"	
12	9.802-632.0	1	CAP, VALVE WITH 1/4" GA PORT	
13	9.802-458.0	1	SWITCH, PRESSURE 1/4" NPT	
14	8.706-207.0	1	ELBOW, 3/8" STREET	
15	8.706-309.0	1	ADAPTER, 3/8" X 3/8" STREET	
16	8.918-423.0	1	HOSE, 3/8" X 22", PRESSURE LOOP	

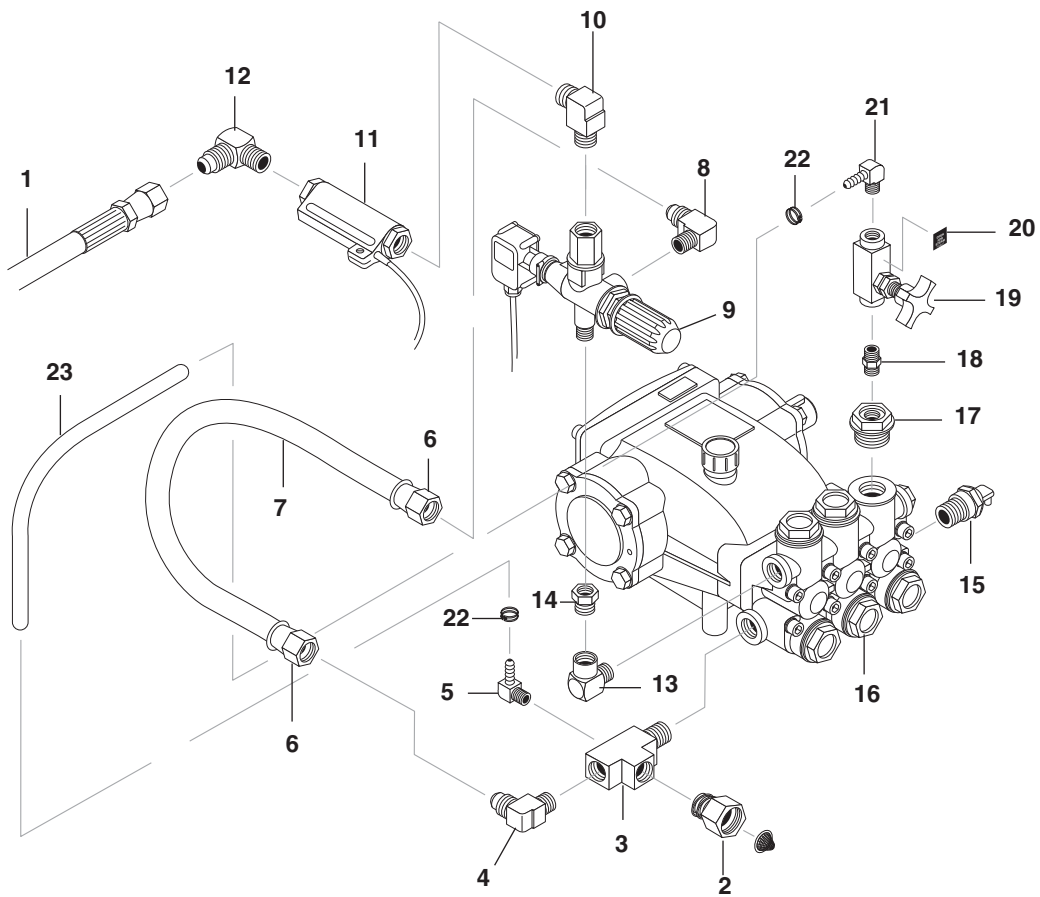

<b>REF</b>	<b>PART NO.</b>	<b>QTY</b>	<b>DESCRIPTION</b>	<b>NOTES</b>
1	8.918-423.0	1	HOSE, 3/8" X 22" PRESSURE LOOP	
2	9.802-146.0	1	SWIVEL, 1/2 X 3/4 GHF W/STRAINER	
3	9.802-123.0	1	TEE, 1/2" W/1/8" HOLE STREET	
4	9.802-131.0	1	ELBOW, 1/2" JIC X 1/2 - 90°	
5	9.802-142.0	1	HOSE BARB, 1/4 BARB X 1/8" PIPE 90°	
6	9.802-151.0	2	SWIVEL, 1/2" JIC FEM, PUSH-ON	
7	9.802-259.0	16"	HOSE, 1/2" PUSH-ON	
8	9.802-129.0	1	ELBOW, 1/2 JIC X 3/8" 90°	
9	9.802-362.0	1	UNLOADER, VB8 W/SWITCH	
10	9.803-044.0	1	ELBOW, 3/8" MALE PIPE	
11	9.802-459.0	1	SWITCH, FLOW	
12	9.802-039.0	1	ELBOW, 1/2 JIC, 3/8"	
13	8.706-207.0	1	ELBOW, 3/8" STREET	
14	8.706-309.0	1	ADAPTER, 3/8" X 3/8" STEEL	
15	8.707-256.0	1	PUMP PROTECTOR 1/2"	
16	-		PUMP	SEE SPECIFICATIONS PAGES
17	9.804-022.0	1	CAP, VALVE W/1/4" GA. PORT	
18	9.802-010.0	1	NIPPLE, 1/4" HEX STEEL	
19	9.802-187.0	1	VALVE, FLOW CONTROL W/METERING	
20	9.802-026.0	1	LABEL, OPEN FOR STEAM	
21	9.802-143.0	1	HOSE BARB, 1/4" BARB X 1/4" PIPE	
22	6.390-126.0	2	CLAMP, HOSE	
23	9.802-254.0	14"	HOSE, 1/4" PUSH-ON	

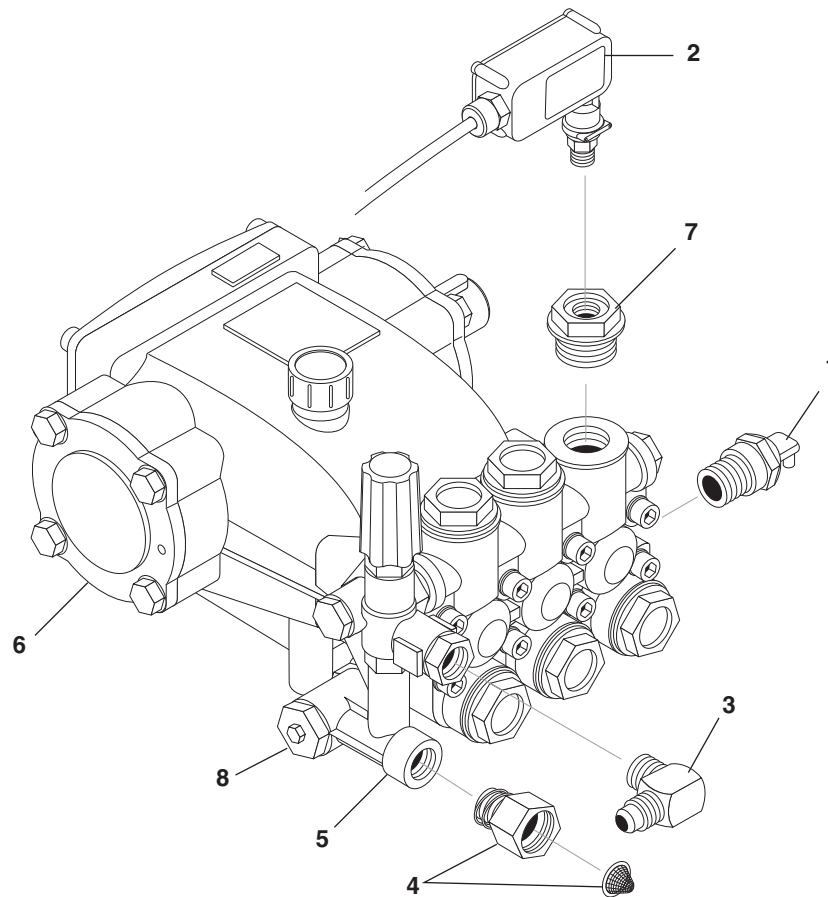

REF	PART NO.	QTY	DESCRIPTION	NOTES
1	8.707-256.0	1	PUMP PROTECTOR, 1/2"	
2	9.802-458.0	1	PRESSURE SWITCH, 1/4"	
3	9.802-039.0	1	ELBOW, 1/2" JIC X 3/8", 90°	
4	9.802-146.0	1	SWIVEL, 1/2" GHF	
5	-	-	UNLOADER	SEE SPECIFICATIONS PAGES
6	-	-	PUMP	SEE SPECIFICATIONS PAGES
7	9.802-632.0	1	CAP, VALVE W/1/4" PORT	
8	8.706-865.0	1	PLUG, 1/8" COUNTERSUNK	

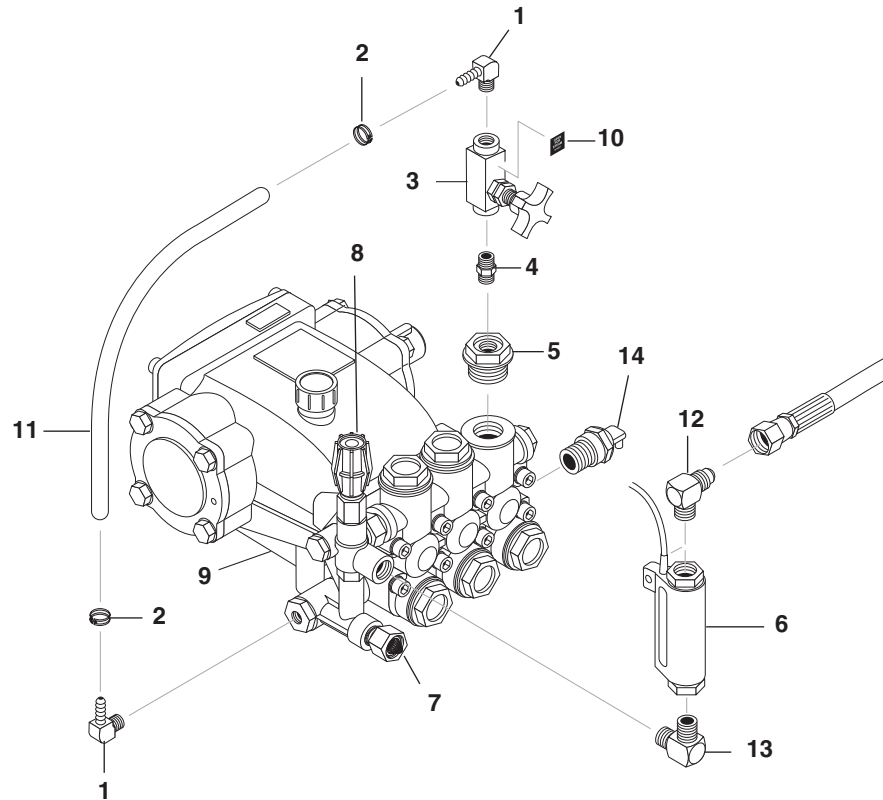

REF	PART NO.	QTY	DESCRIPTION	NOTES
1	8.706-958.0	2	HOSE BARB, 1/4" BARB X 1/4" NPT, 90°	
2	6.390-126.0	2	CLAMP, HOSE, .46-, .54 ST	
3	9.802-187.0	1	VALVE, FLOW CONTROL W/METERING	
4	8.705-973.0	1	NIPPLE, 1/4" HEX STEEL	
5	9.802-632.0	2	CAP, VALVE WITH 1/4" GAUGE PORT	
6	8.933-006.0	1	SWITCH, MV-60 FLOW	
7	9.802-146.0	1	SWIVEL, 1/2" MP X 3/4" GHF W/STRAINER	
8	-	-	UNLOADER	SEE SPECIFICATIONS PAGES
9	-	-	PUMP	SEE SPECIFICATIONS PAGES
10	9.800-026.0	1	LABEL, OPEN FOR STEAM	
11	9.802-254.0	14"	HOSE, 1/4" PUSH-ON	
12	9.802-039.0	1	ELBOW, 1/2" JIC X 3/8"	
13	8.706-168.0	1	ELBOW, 3/8" MPT	
14	8.707-256.0	2	PUMP PROTECTOR, 1/2"	

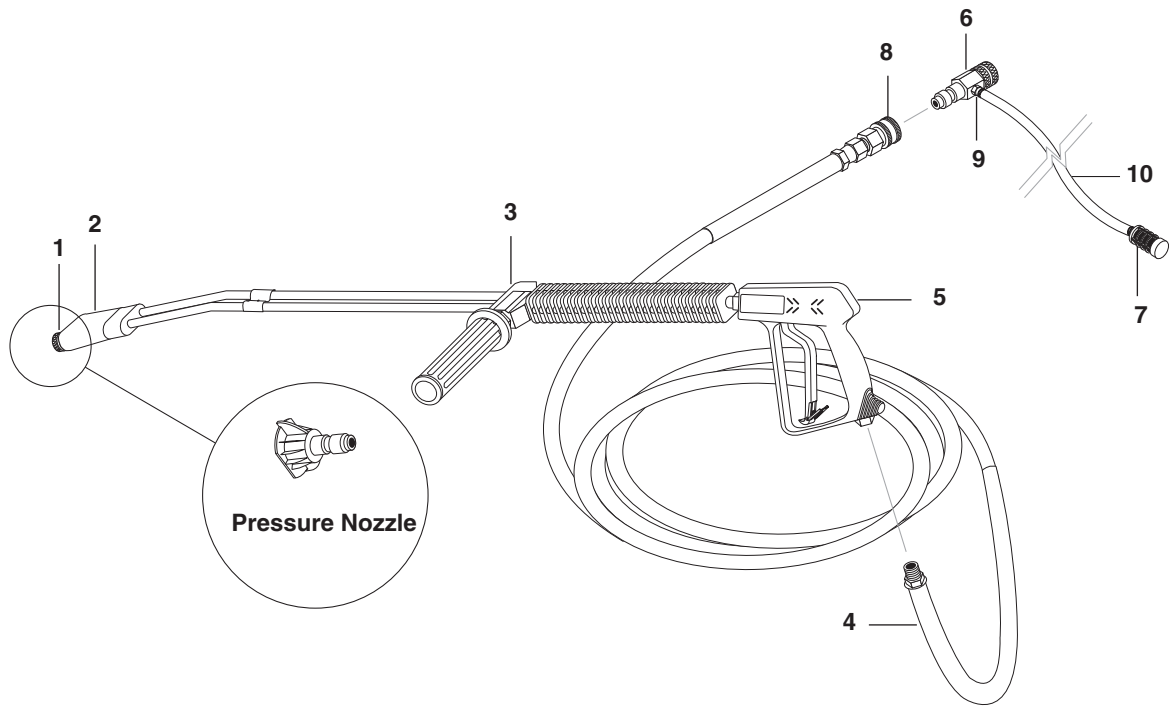



REF	PART NO.	QTY	DESCRIPTION	NOTES
1	9.802-165.0	1	COUPLER, 1/4" MALE	
-	9.802-096.0	1	QUICK COUPLER O-RING, SMALL	NOT SHOWN
2	9.802-286.0	1	NOZZLE ONLY, 1/8" SOAP	NOT SHOWN
3	9.802-222.0	1	WAND, ZINC, VP, W/COUPLER	
4	8.917-057.0	1	HOSE, 3/8" X 50' 1 WIRE	
5	8.710-384.0	1	GUN, ST-1500, 5000 PSI 10.4 GPM	
6	9.802-225.0	1	DETERGENT INJECTOR NON ADJUST #3	(504.0, 505.0, 508.0, 509.0, 510.0)
7	9.802-160.0	1	STRAINER, 1/4" HOSE BARB	
8	9.802-166.0	1	COUPLER, 3/8" FEMALE	
-	9.802-100.0	1	QUICK COUPLER, O-RING, LARGE	NOT SHOWN
9	6.390-126.0	2	CLAMP, HOSE, .46-, .54 ST	
10	9.802-251.0	6 ft.	TUBE, 1/4" X 1/2" CLEAR VINYL	

**9.175-018.0, 3500 PSI**  
Universal Unloader

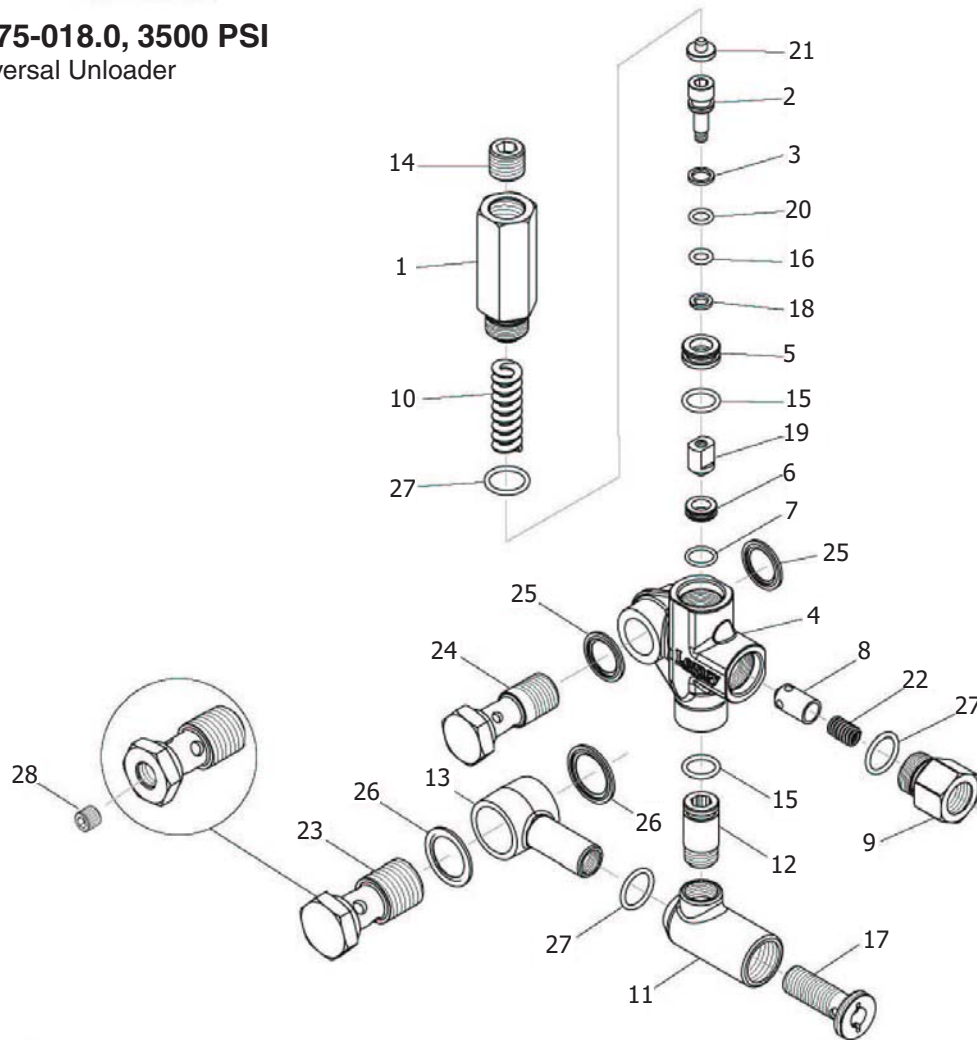

REF	PART NO.	QTY	DESCRIPTION	NOTES
1	-	1	PISTON HOUSING	KIT A
2	-	1	PISTON	KIT C
3	8.749-795.0	1	PISTON O-RING BACK UP	
4	8.749-796.0	1	MAIN BLOCK	
5	9.152-372.0	1	PISTON RING	
6	-	1	BALL SEAT	KIT C
7	-	1	O-RING, 10.5 ID X 1.5 CS	KIT A,C
8	-	1	PLUNGER	KIT B
9	9.152-016.0	1	PLUNGER HOUSING	
10	-	1	BYPASS SPRING	KIT C
11	9.149-001.0	1	LOW PRESSURE PORT	
12	9.152-017.0	1	SLIDING CONNECTOR, 30 MM	
-	8.762-005.0	1	SLIDING CONNECTOR, 40 MM	
13	9.149-002.0	1	SLIDING CONNECTOR H 1/2"	
-	9.149-005.0	1	SLIDING CONNECTOR H 3/8"	
14	9.196-011.0	1	PLUG, 5/8 - 18 UNF	
15	-	2	O-RING 12 ID X 2 CS	KIT A
16	-	1	O-RING 6 ID X 2 CS	KIT A
17	9.149-006.0	1	SLIDING CONNECTOR GUIDE	
18	-	1	O-RING BACK UP	KIT A
19	-	1	CONICAL SEAL	KIT C
20	-	1	O-RING 6.75 X 1.78 BN80	KIT A
21	-	1	SPRING SEAT	KIT C
22	-	1	PLUNGER SPRING	KIT B
23	8.762-001.0	1	BANJO BOLT, 1/2"	
-	8.762-011.0	1	BANJO BOLT, 1/2" - 1/4" NPT	
-	8.762-000.0	1	BANJO BOLT 3/8"	
24	8.762-000.0	1	BANJO BOLT 3/8"	
25	9.802-893.0	2	SEAL WASHER 3/8"	
26	9.803-921.0	2	SEAL WASHER, 1/2"	(0120, 0130)
-	9.802-893.0	2	SEAL WASHER 3/8"	(0140)
27	-	3	O-RING 15 ID X 2 CS	KIT A,B
28	8.706-865.0	1	PLUG, 1/4"	
<b>KIT A</b>	9.104-038.0	-	O-RING REPAIR KIT	
<b>KIT B</b>	9.104-039.0	-	OUTLET KIT	
<b>KIT C</b>	9-104-040.0	-	STEM REPAIR KIT	

## KM.3 Series Pump

8.751-186.0 KM3540R.3  
 8.751-187.0 KM4030R.3  
 8.751-188.0 KM4030L.3  
 8.751-189.0 KM4035R.3  
 8.751-190.0 KM4035L.3  
 8.751-191.0 KM5030R.3  
 8.751-192.0 KM5030L.3

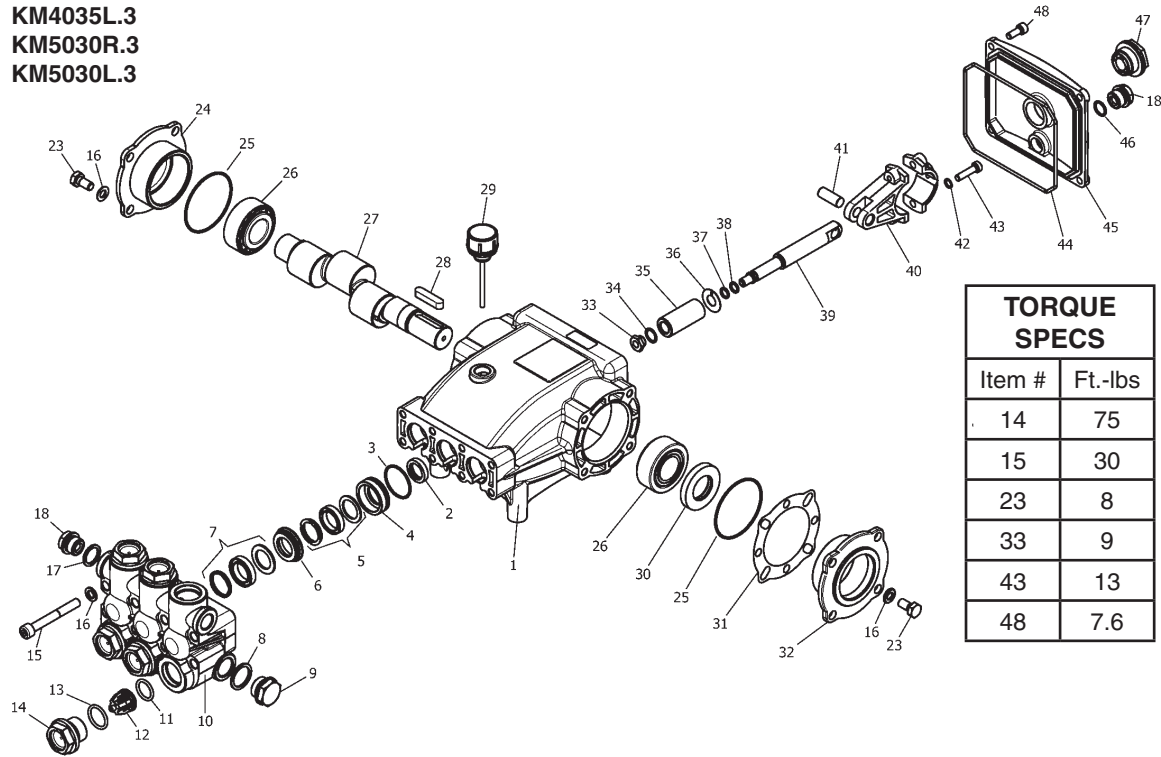

TORQUE SPECS	
Item #	Ft.-lbs
14	75
15	30
23	8
33	9
43	13
48	7.6

REF	PART NO.	QTY	DESCRIPTION	NOTES
1	8.751-216.0	1	CRANKCASE	
2	-	3	PLUNGER OIL SEAL	SEE KITS TABLE
3	-	3	O-RING Ø1.78 X 31.47	SEE KITS TABLE
4	-	3	PRESSURE RING	SEE KITS TABLE
5	-	3	U-SEAL	SEE KITS TABLE
6	-	3	INTERMEDIATE RING	SEE KITS TABLE
7	-	3	U-SEAL	SEE KITS TABLE
8	9.803-199.0	1	WASHER, COPPER	
9	9.802-926.0	1	PLUG, BRASS 1/2	
10	8.751-218.0	1	MANIFOLD HEAD	
11	-	6	O-RING Ø2.62 X 17.13	SEE KITS TABLE
12	-	6	VALVE ASSEMBLY	SEE KITS TABLE
13	-	6	O-RING Ø2.62 X 20.29	SEE KITS TABLE
14	9.802-928.0	6	VALVE PLUG	
15	9.802-938.0	8	MANIFOLD STUD BOLT	
16	9.802-884.0	16	WASHER	
17	9.803-198.0	1	COPPER WASHER 3/8	
18	9.802-925.0	1	BRASS PLUG 3/8	
23	9.802-944.0	8	SCREW, HEX, 8MM X18MM	

REF	PART NO.	QTY	DESCRIPTION	NOTES
24	8.717-210.0	1	CLOSED BEARING HOUSING	
25	9.803-192.0	2	O-RING Ø1.78 X 60.05	
26	8.933-011.0	2	TAPERED ROLLER BEARING	
27	8.751-222.0	1	CRANKSHAFT (5030,3540)	
-	8.751-223.0	1	CRANKSHAFT (4030, 4035)	
28	9.803-167.0	1	CRANKSHAFT KEY	
29	9.802-921.0	1	OIL DIP STICK	
30	9.803-140.0	1	CRANKSHAFT SEAL	
31	9.803-178.0	2	SHIM	
32	8.717-209.0	1	BEARING HOUSING	
33	-	3	PLUNGER NUT, M8	SEE KITS TABLE
34	-	3	COPPER SPACER	SEE KITS TABLE
35	-	3	PLUNGER (4035)	SEE KITS TABLE
-	-	3	PLUNGER (4030, 5030)	SEE KITS TABLE
-	-	3	PLUNGER (3540)	SEE KITS TABLE
36	-	3	COPPER SPACER	SEE KITS TABLE
37	-	3	O-RING Ø1.78 X 7.66	SEE KITS TABLE
38	-	3	TEFLON RING	SEE KITS TABLE
39	8.751-224.0	3	PLUNGER ROD	
40	9.803-158.0	3	CONNECTING ROD	
41	8.751-228.0	3	CONNECTING ROD PIN	
42	9.803-218.0	6	SPRING WASHER	
43	9.803-238.0	6	CONNECTING ROD SCREW	
44	8.933-016.0	1	O-RING, Ø2.62 X 126.67	
45	8.751-229.0	1	CRANKCASE COVER	
46	9.803-197.0	1	O-RING, Ø1.78 X 14	
47	9.803-202.0	1	SIGHT GLASS 3/4	
48	9.802-939.0	5	COVER SCREW	

KIT NUMBERS	8.725-360.0	8.725-362.0	8.725-358.0	8.725-361.0	8.725-363.0	8.725-359.0
KIT DESCRIPTION	Plunger Seal 4035 18mm	Plunger Seal 4030 5030 20mm	Plunger Seal 3540 15mm	Complete Seal Packing 4035 18mm	Complete Seal Packing 4030 5030 20mm	Complete Seal Packing 3540 15mm
ITEM NUMBERS INCLUDED	3, 5, 7	3, 5, 7	3, 5, 7	3, 4, 5, 6, 7	3, 4, 5, 6, 7	3, 4, 5, 6, 7
NUMBER OF CYLINDERS KIT WILL SERVICE	3	3	3	1	1	1

KIT NUMBERS	8.751-237.0	8.751-238.0	8.933-023.0	9.802-603.0	9.802-609.0
KIT DESCRIPTION	Plunger 4035 18mm	Plunger 4030 5030 20mm	Plunger 3540 15mm	Complete Valve	Plunger Oil Seals
ITEM NUMBERS INCLUDED	33, 34, 35, 36, 37, 38	33, 34, 35, 36, 37, 38	33, 34, 35, 36, 37, 38	11, 12, 13	2
NUMBER OF CYLINDERS KIT WILL SERVICE	1	1	1	6	3

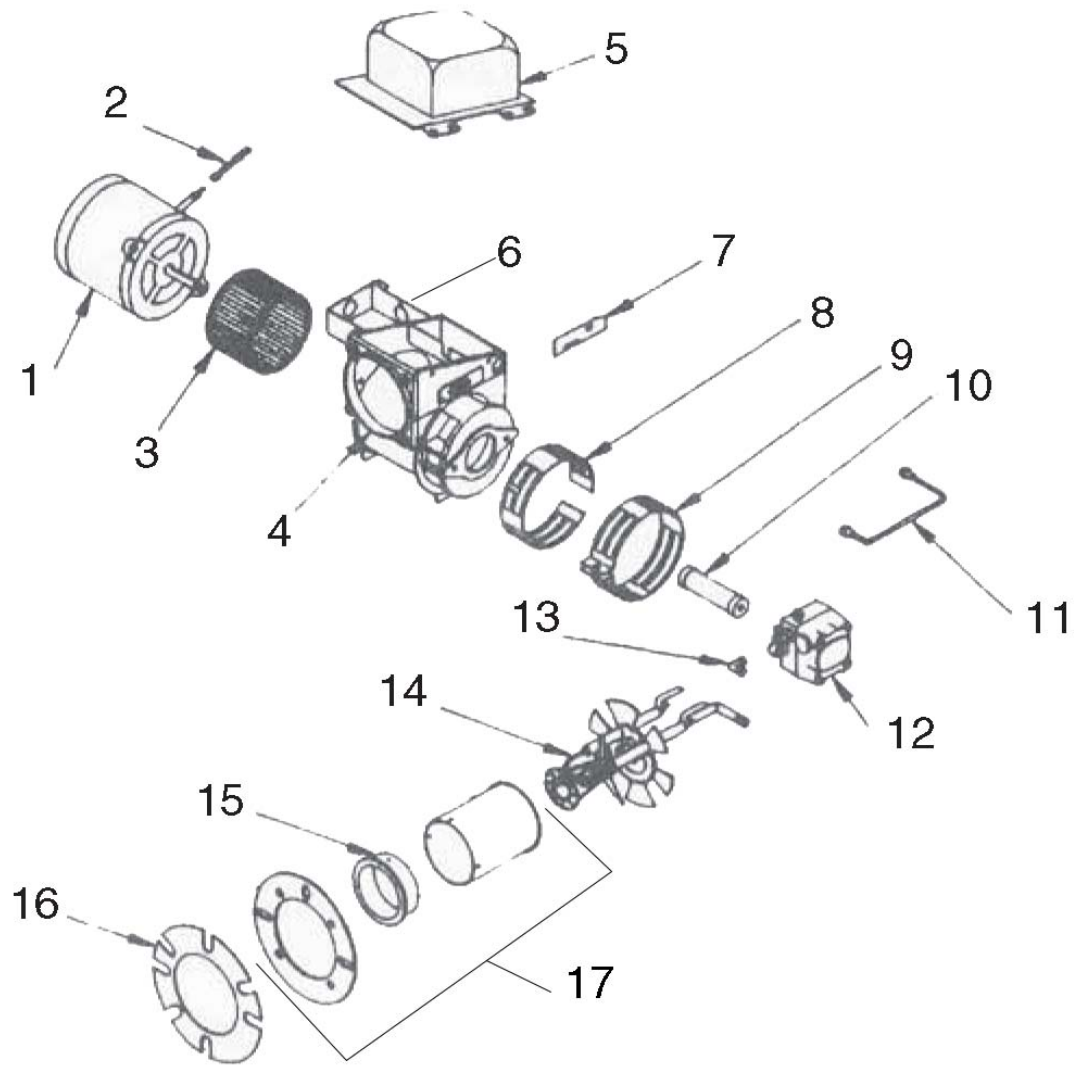

REF	PART NO.	QTY	DESCRIPTION	NOTES
1	8.756-293.0	1	MOTOR, BURNER, 1/5 120V 50-60HZ	120V
-	8.756-294.0	1	MOTOR, BURNER, 1/5 230V 50-60HZ	230V
2	13121	1	MOTOR CORD COVER	
3	8.700-730.0	1	BLOWER WHEEL, 5-.25' x 3-7/16(307000)	
4	8.700-735.0	1	BURNER HOUSING EHASR	
5	8.700-802.0	1	IGNITOR, 120V, SIDE/EH-EHA MOUNT	120V
-	8.756-291.0	1	IGNITOR, BURNER, "E" 240 50-60	230V
6	8.756-742.0	1	JUNCTION BOX, EHASR, BLACK BODY	
-	8.756-741.0	1	JUNCTION BOX, EHASR, BLACK COVER	NOT SHOWN
-	8.756-743.0	1	PLUG, HOLE, JUNCTION BOX, M&E	NOT SHOWN
7	13392	1	SLOT COVER PLATE	
8	8.700-732.0	1	BAND, AIR BURNER INNER EHA/SR	
9	8.700-729.0	1	AIR BAND 8 HOLE OUTER EHA/SR	
10	13279	1	COUPLING A/B PUMP	
11	8.700-704.0	1	OIL LINE, 6'	
12	8.756-290.0	1	FUEL PUMP, WCS - COMBO/W SOLENOID 120V	
13	13494	1	BRASS 90° ELBOW	
14	8.756-450.0	1	GUN ASSEMBLY, BURNER-RG/*CST/GBB1	
15	8.756-302.0	1	AIR CONE #8A	
16	8.700-692.0	2	GASKET, E & M SERIES BURNERS	
17	8.756-678.0	1	FLANGE, AIR TUBE, WELDED	
-	8.700-723.0	1	ELEC ASSB PAIR/FOR12V/MSRDC&E-SRIES BRNR	NOT SHOWN

## Specifications

### Pump

MODEL	PUMP MODEL #	PUMP PARTS	UNLOADER REPLACEMENT	UNLOADER PRODUCTION	PULLY	PULLY PART #
1.575-505.0	KM-4035	9.175-189.0	9.175-018.0	9.175-016.0	2AK74H	9.802-374.0
1.575-508.0	KM-4035	9.175-189.0	9.175-018.0	9.175-016.0	2BK80H	9.802-389.0
1.575-509.0	KM-4035	9.175-189.0	9.175-018.0	9.175-016.0	2BK80H	9.802-389.0
1.575-510.0	KM-4035	9.175-189.0	9.175-018.0	9.175-016.0	2BK80H	9.802-389.0

### Motor

MODEL	MOTOR SIZE	VOLTAGE	MOTOR PART #	PULLY	PULLY PART #	BUSHING	BUSHING PART #
1.575-505.0	6HP	230v/1ph/60Hz	9.802-336.0	2AK54H	8.715-550.0	Hx1-1/8"	9.802-400.0
1.575-508.0	7.5HP	230v/1ph/60Hz	8.715-097.0	2BK52H	9.802-386.0	Hx1-3/8"	9.802-401.0
1.575-509.0	7.5HP	230v/3ph/60Hz	8.755-604.0	2BK50H	8.715-583.0	Hx1-3/8"	9.802-401.0
1.575-510.0	7.5HP	460v/3ph/60Hz	8.755-604.0	2BK50H	8.715-583.0	Hx1-3/8"	9.802-401.0

MODEL	BELT SIZE	BELT PART #	MOTOR CONTACTOR
1.575-505.0	AX 36(2)	9.802-408.0	8.724-281.0
1.575-508.0	BX 36(2)	9.802-416.0	8.724-281.0
1.575-509.0	BX 36(2)	9.802-416.0	8.724-272.0
1.575-510.0	BX 36(2)	9.802-416.0	8.724-268.0



**Controls**

MODEL	OVERLOAD	STEPDOWN TRANSFORMER	PRIMARY FUSE PART #	SECOND FUSE PART #
1.575-505.0	N/A	9.802-551.0	9.802-460.0	9.802-463.0
1.575-508.0	8.724-306.0	9.802-551.0	8.933-007.0	9.802-463.0
1.575-509.0	8.724-305.0	9.802-551.0	9.802-460.0	9.802-463.0
1.575-510.0	8.724-312.0	9.802-550.0	9.802-465.0	8.749-743.0

**Wayne EHASR Burner**

MODEL	BURNER ASSY NO.	FUEL NOZZLE W/ 100PSI CHECK VALVE
1.575-505.0	8.756-737.0	8.755-763.0
1.575-508.0	8.756-737.0	8.755-763.0
1.575-509.0	8.756-737.0	8.755-763.0
1.575-510.0	8.756-738.0	8.755-763.0

**Burner Replacement Parts**

PART NO.	QTY	DESCRIPTION	NOTES
8.756-409.0	2	CONNECTOR, LEVER NUT, 2-WIRES	8.756-737.0
8.756-410.0	2	CONNECTOR, LEVER NUT, 3-WIRES	8.756-737.0
8.756-409.0	1	CONNECTOR, LEVER NUT, 2-WIRES	8.756-738.0
8.756-410.0	1	CONNECTOR, LEVER NUT, 3-WIRES	8.756-738.0
8.756-411.0	1	CONNECTOR, LEVER NUT, 5-WIRES	8.756-738.0

**KÄRCHER**

A thick, solid black horizontal bar that serves as an underline for the Kärcher brand name.

9.800-078.0 • Printed in U.S.A.