

# KÄRCHER

makes a difference

**High Pressure Cleaner**  
**Combustion engine - Cold Water**

English..... 3

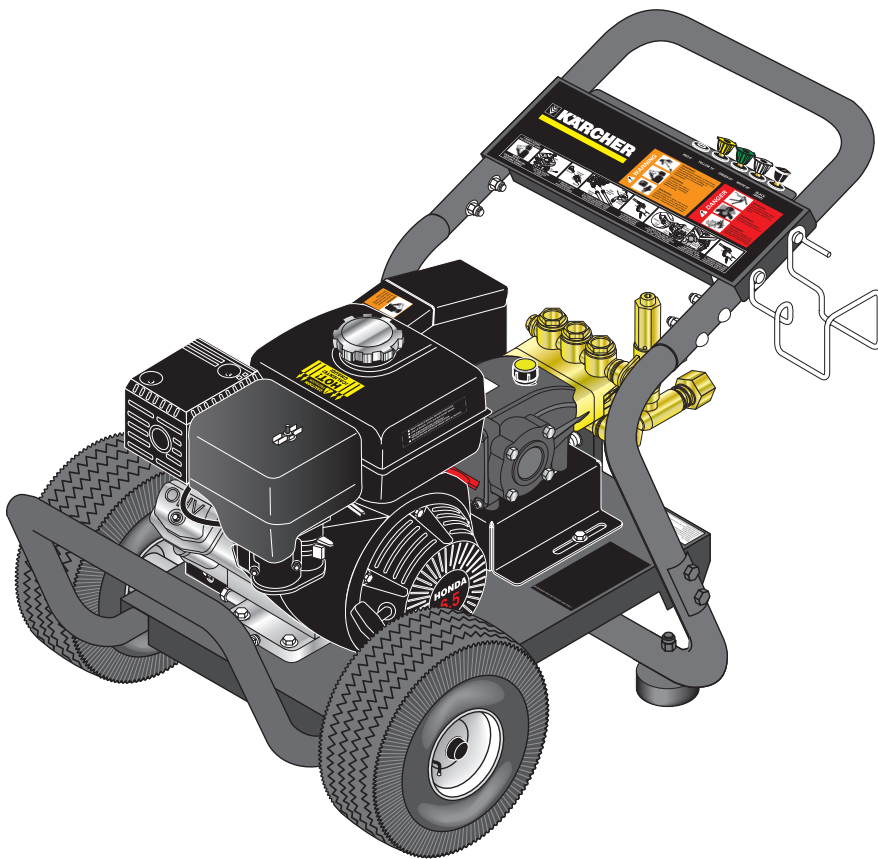

## SHOP PRESSURE WASHER PARTS

[shoppressurewasherparts.com](http://shoppressurewasherparts.com) | (888) 269-0172



**Register  
your product**

[www.kaercher.com/welcome](http://www.kaercher.com/welcome)



98076230 (03/20)

**MODELS:**

**1.575-152.0**  
HD 3.0/30 Pb

**1.575-154.0**  
HD 3.7/35 Pb

**1.575-155.0**  
HD 3.0/40 Pb

# CONTENTS

---

Introduction & Important Safety Information .....	4-5
Component Identification .....	6
Assembly Instructions.....	7
Operating Instructions.....	8-9
Detergents & Cleaning Techniques.....	10
Shut Down and Clean-Up .....	11
Storage .....	11
Troubleshooting .....	12
Adjusting Unloader Valves .....	12
Preventative Maintenance .....	13
Oil Change Record .....	13
Models 152.0, 154.0,155.0 Exploded View.....	14
Models 152.0, 154.0, 155.0 Exploded View Parts List .....	15-16
Specifications.....	17-19
Hose and Spray Gun Assembly.....	19
VRT3 Unloader Exploded View and Parts List.....	20
UU1 Unloader Exploded View and Parts List .....	21
VBT Unloader Exploded View and Parts List.....	22
KM.3 Pump Exploded View and Parts List .....	23-24
KB3030R Pump Exploded View and Parts List .....	25-26

Model Number \_\_\_\_\_

Serial Number \_\_\_\_\_

Date of Purchase \_\_\_\_\_

The model and serial numbers will be found on a decal attached to the pressure washer. You should record both serial number and date of purchase and keep in a safe place for future reference.

# INTRODUCTION & IMPORTANT SAFETY INFORMATION

Thank you for purchasing this Pressure Washer.

We reserve the right to make changes at any time without incurring any obligation.

## Owner/User Responsibility:

The owner and/or user must have an understanding of the manufacturer's operating instructions and warnings before using this pressure washer. Warning information should be emphasized and understood. If the operator is not fluent in English, the manufacturer's instructions and warnings shall be read to and discussed with the operator in the operator's native language by the purchaser/owner, making sure that the operator comprehends its contents.

Owner and/or user must study and maintain for future reference the manufacturers' instructions.

The operator must know how to stop the machine quickly and understand the operation of all controls. Never permit anyone to operate the engine without proper instructions.

## SAVE THESE INSTRUCTIONS

This manual should be considered a permanent part of the machine and should remain with it if machine is resold.

When ordering parts, please specify model and serial number. Use only identical replacement parts.

This machine is to be used only by trained operators.

## IMPORTANT SAFETY INFORMATION

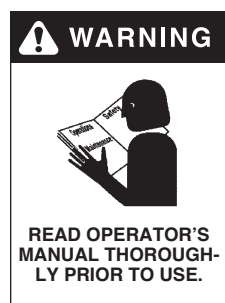

**WARNING: To reduce the risk of injury, read operating instructions carefully before using.**

1. Read the owner's manual thoroughly. Failure to follow instructions could cause malfunction of the machine and result in death, serious bodily injury and/or property damage.
2. Know how to stop the machine and bleed pressure quickly. Be thoroughly familiar with the controls.
3. Stay alert — watch what you are doing.
4. All installations must comply with local codes. Contact your electrician, plumber, utility company or the selling distributor for specific details.



**WARNING: Risk of asphyxiation. Use this product only in a well ventilated area.**

5. Avoid installing machines in small areas or near exhaust fans. Exhaust contains poisonous carbon monoxide gas; exposure may cause loss of consciousness and may lead to death. It also contains

chemicals known, in certain quantities, to cause cancer, birth defects or other reproductive harm.



**WARNING: Risk of fire. Do not add fuel when the product is operating.**

**WARNING: Risk of explosion — do not spray flammable liquids.**

6. Do not place machine near flammable objects as the engine is hot.

**WARNING: This product contains chemicals known to the state of California to cause cancer and birth defects or other reproductive harm. Operation of this equipment may create sparks that can start fires around dry vegetation. A spark arrestor may be required. The operator should contact: Local fire agencies for laws or regulations relating to fire prevention requirements.**

7. Allow engine to cool for 1-2 minutes before refueling. If any fuel is spilled, make sure the area is dry before testing the spark plug or starting the engine. (Fire and/or explosion may occur if this is not done.)

Gasoline engines on mobile or portable equipment shall be refueled:

- a. outdoors;
- b. with the engine on the equipment stopped;
- c. with no source of ignition within 10 feet of the dispensing point; and
- d. with an allowance made for expansion of the fuel should the equipment be exposed to a higher ambient temperature.

In an overfilling situation, additional precautions are necessary to ensure that the situation is handled in a safe manner.

**WARNING: Risk of injury. Disconnect battery ground terminal before servicing.**

8. Transport/repair with fuel tank EMPTY or with fuel shut-off valve OFF.

# IMPORTANT SAFETY INFORMATION

**WARNING**



KEEP WATER SPRAY AWAY FROM ELECTRICAL WIRING.

**WARNING:** Keep wand, hose, and water spray away from electric wiring or fatal electric shock may result.

- Do not spray water on or near electrical components.

**WARNING**



RISK OF INJECTION OR SEVERE INJURY TO PERSONS. KEEP CLEAR OF NOZZLE.

**WARNING:** High pressure developed by these machines will cause personal injury or equipment damage. Keep clear of nozzle. Use caution when operating. Do not direct discharge stream at people, or severe injury or death will result.

**WARNING**



RISK OF EXPLOSION: DO NOT SPRAY FLAMMABLE LIQUIDS.

**WARNING:** Flammable liquids can create fumes which can ignite, causing property damage or severe injury.

**WARNING:** Risk of explosion – Do not spray flammable liquids.

- Keep operating area clear of all persons.

**WARNING**



PROTECT FROM FREEZING

**WARNING:** Protect machine from freezing.

13. Never make adjustments on machine while in operation.

14. Be certain all quick coupler fittings are secured before using pressure washer.

15. To keep machine in best operating conditions, it is important you protect machine from freezing. Failure to protect machine from freezing could cause malfunction of the machine and result in death, serious bodily injury, and/or property damage. Follow storage instructions specified in this manual.

**WARNING**



EAR PROTECTION MUST BE WORN

**WARNING:** This machine exceeds 85 db appropriate ear protection must be worn.

**WARNING**



RISK OF INJURY FROM FALLS WHEN USING LADDER.

**WARNING:** Be extremely careful when using a ladder, scaffolding or any other relatively unstable location. The cleaning area should have adequate slopes and drainage to reduce the possibility of a fall due to slippery surfaces.

**WARNING**



USE PROTECTIVE EYE WEAR AND CLOTHING WHEN OPERATING THIS EQUIPMENT.

**WARNING:** High pressure spray can cause paint chips or other particles to become airborne and fly at high speeds. To avoid personal injury, eye, hand and foot safety devices must be worn.

- Eye, hand, and foot protection must be worn when using this equipment.

17. Do not overreach or stand on unstable support. Keep good footing and balance at all times.

**WARNING**



TRIGGER GUN KICKS BACK - HOLD WITH BOTH HANDS

**WARNING:** Grip cleaning wand securely with both hands before starting. Failure to do this could result in injury from a whipping wand.

- To reduce the risk of injury, close supervision is necessary when a machine is used near children. Do not allow children



**Follow the maintenance instructions specified in the manual.**

to operate the pressure washer. **This machine must be attended during operation.**

## COMPONENT IDENTIFICATION

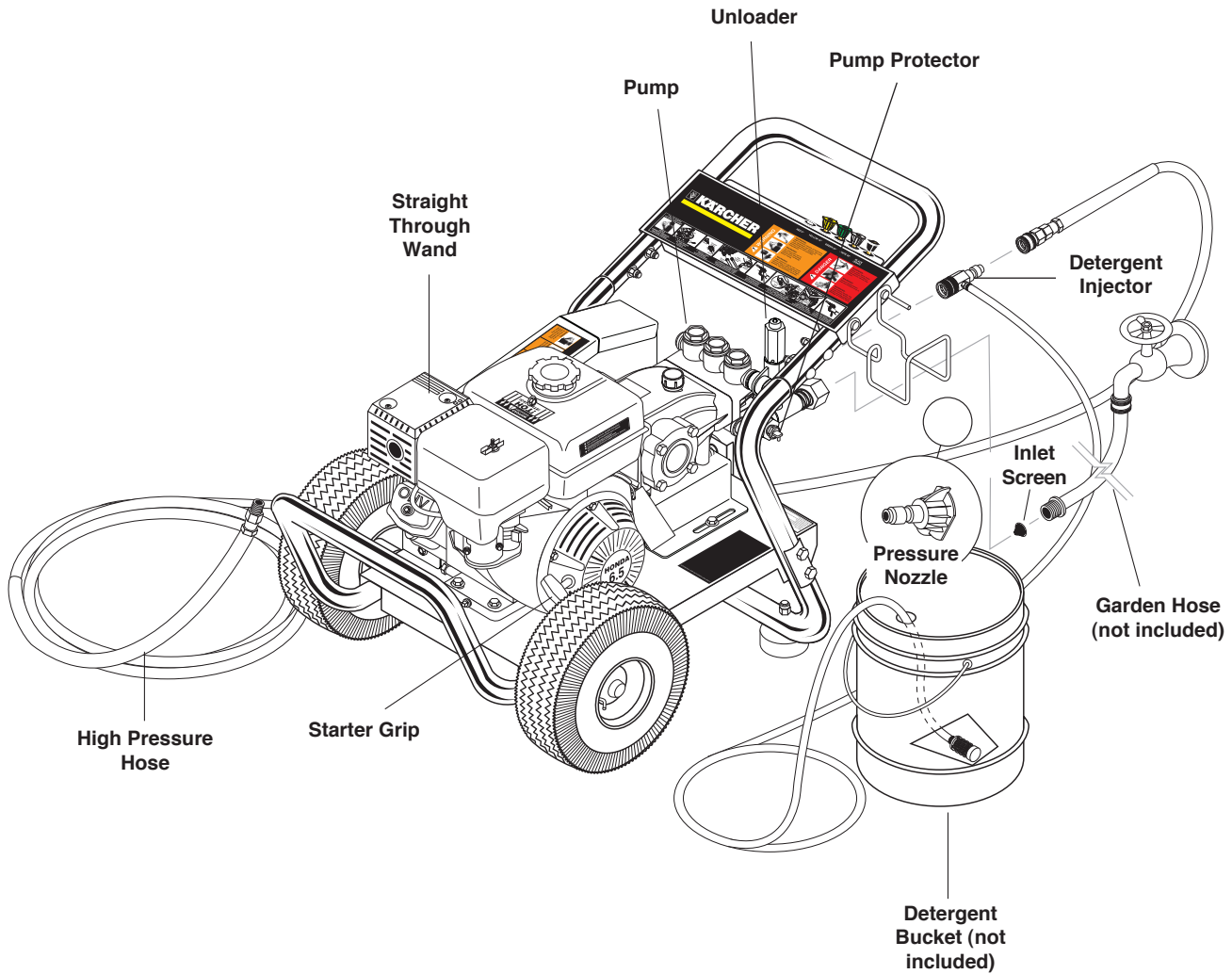

**Pump** — Develops high pressure.

**Starter Grip** — Used for starting the engine manually.

**Spray Gun** — Controls the application of water and detergent onto cleaning surface with trigger device. Includes safety latch.

**Detergent Injector** — Allows you to siphon and mix detergents.

**Wand** — Must be connected to the spray gun.

**High Pressure Hose** — Connect one end to water pump discharge nipple (detergent injector nipple) and the other end to spray gun.

**Note:** If trigger on spray gun is released for more than 1-2 minutes, water may leak from pump protector. Warm water will discharge from pump protector onto floor. This system prevents internal pump damage from high temperatures.

# ASSEMBLY INSTRUCTIONS

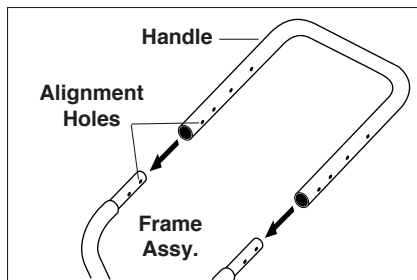

**STEP 1:** Attach the handle to the frame of the pressure washer. **Note:** It may be necessary to move the handle supports from side to side in order to align the handle so it will slide over the frame supports.

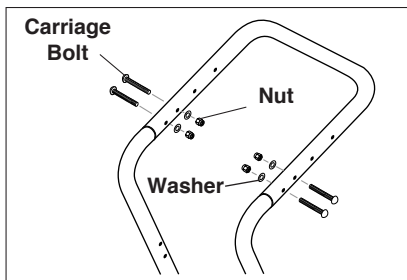

**STEP 2:** Insert the carriage bolt through the holes from the outside of the unit and attach a nut from the inside of the machine. Tighten nuts.

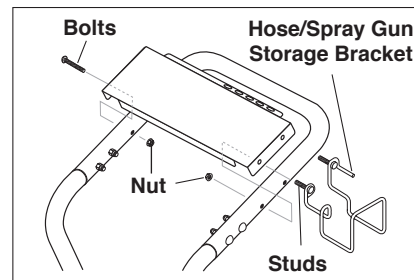

**STEP 3:** Attach the spray gun/hose storage handle, and bracket to handle. Tighten nuts.

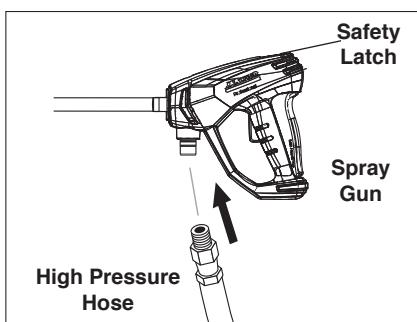

**STEP 4:** Attach the high pressure hose to the spray gun using teflon tape on hose threads.

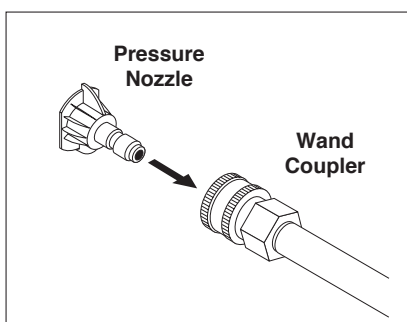

**STEP 5:** Pull the spring-loaded collar of the wand coupler back to insert your choice of pressure nozzle.

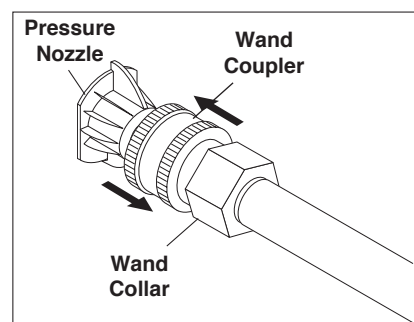

**STEP 6:** Release the coupler collar and push the nozzle and the collar until the collar clicks or locks. Pull the nozzle to make sure it is secure.

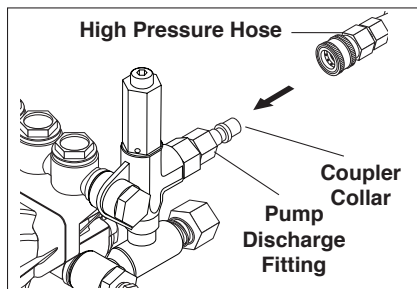

**STEP 7:** Connect high pressure hose to pump discharge fitting. Push coupler collar forward until secure.

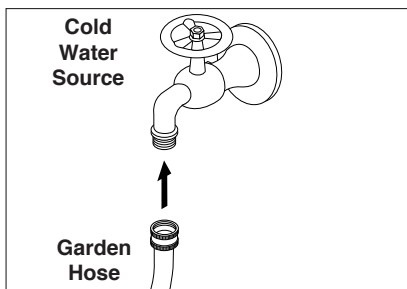

**STEP 8:** Connect garden hose to a clean cold water source and open supply valve completely. **NEVER** use hot water.

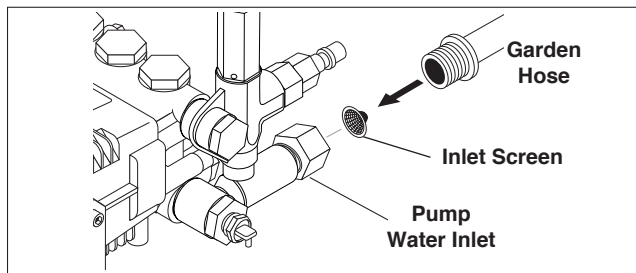

**STEP 9:** Connect the garden hose to pump water inlet. Inspect inlet screen. **CAUTION: Do not run the pump without water or pump damage will result.**

# OPERATING INSTRUCTIONS

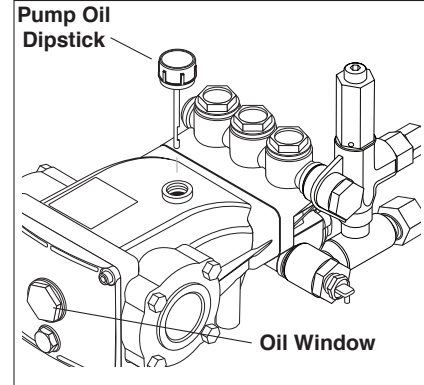
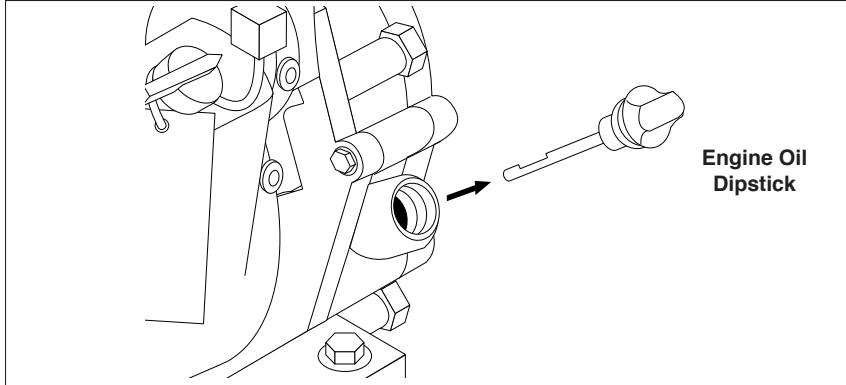

**STEP 1:** Check engine oil level. Oil level should be level with the bottom of the oil filler neck. Be sure the machine is level when checking the oil level. (Refer to the engine's operating manual included with machine.) We recommend that the oil be changed after the first 5 hours of use, then once every 50 hours. **Note:** Improper oil levels will cause low oil sensor to shut off engine. **IMPORTANT! Do not run engine with high or low oil levels as this will cause engine damage.**

**STEP 2:** Remove shipping cap and install oil dipstick. Check pump oil level by using dipstick or observe oil level in oil window (if equipped). Use 30 wt. (non detergent) oil.

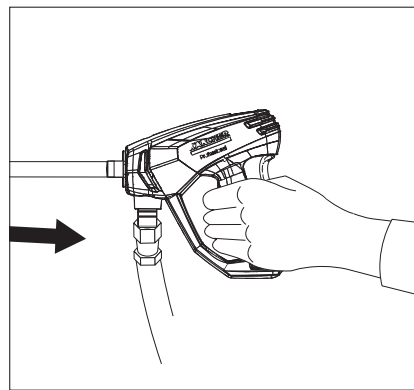
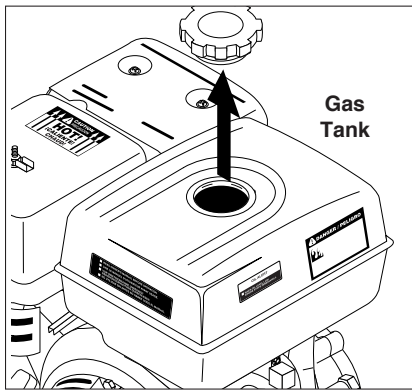

**STEP 3:** Fill gas tank with unleaded gasoline. Do not use leaded gasoline.

**STEP 4:** Trigger the spray gun to eliminate trapped air then wait for a steady flow of water to emerge from the spray nozzle.

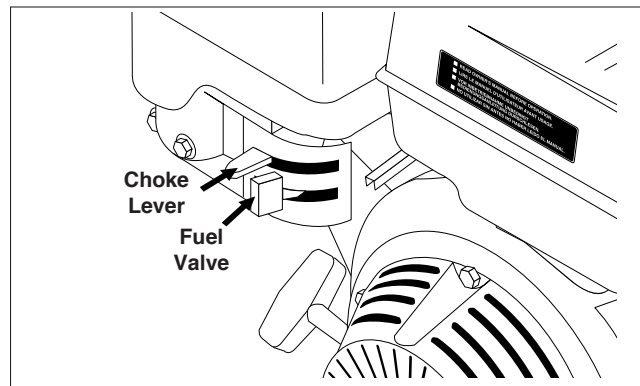
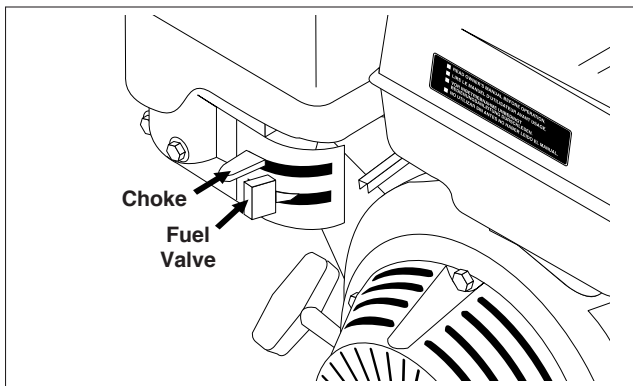

**STEP 5:** Move the fuel shut-off valve to the "On" position. When the engine is not in use, leave the fuel valve in the "OFF" position.

**STEP 6:** Move the choke lever to the "Choke" position (on a warm engine, leave the choke lever in the run position). Move the choke lever to the "Closed" position. To restart a warm engine, leave the choke lever in the "Open" position.



## OPERATING INSTRUCTIONS (CONT.)

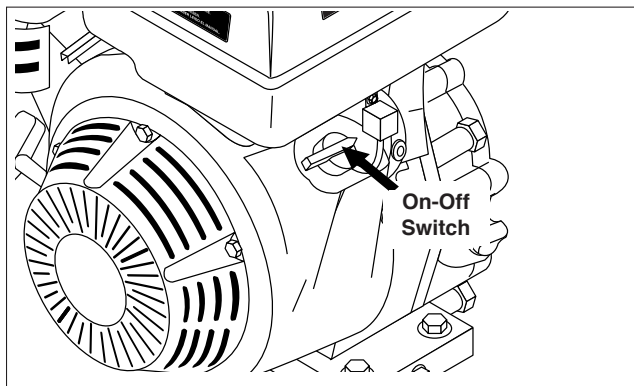

**STEP 7:** Turn the engine switch to "On" position. On Briggs engines, move the throttle lever to "Fast" position, shown on engine as a rabbit.

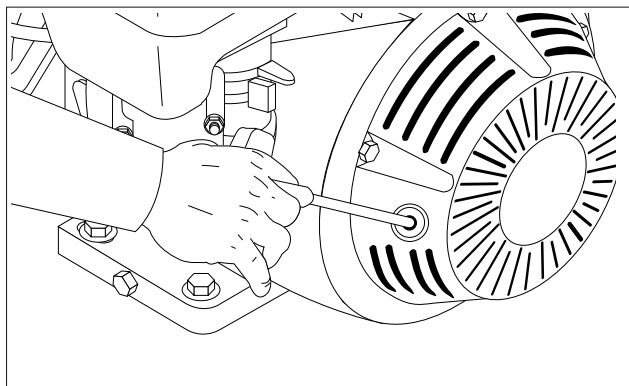

**STEP 8:** Pull the starter grip. If the engine fails to start after 2 pulls, squeeze the trigger gun to release pressure and repeat step. Return starter gently. After the engine warms up enough to run smoothly, move choke to run position and throttle to fast position.

**CAUTION:** Small engines may kick back. Do not hold pull starter grip tightly in hand.

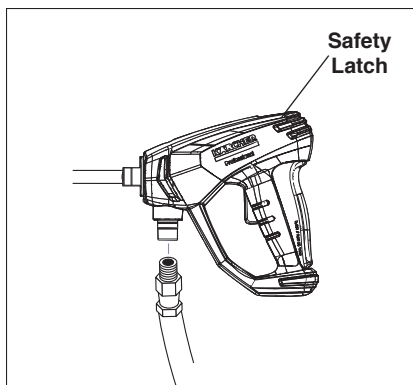

**WARNING!** Never replace nozzles without engaging the safety latch on the spray gun trigger.



The four color-coded quick connect nozzles provide a wide array of spray widths from 15° to 40° and are easily accessible when placed in the convenient rubber nozzle holder, which is provided on the front of the machine.

**NOTE:** For a more gentle rinse, select the white 40° or green 25° nozzle. To scour the surface, select the yellow 15° nozzle. To apply detergent select the black nozzle.

## DETERGENTS & GENERAL CLEANING TECHNIQUES

### WARNING



**WARNING:** Some detergents may be harmful if inhaled or ingested, causing severe nausea, fainting or poisoning. The harmful elements may cause property damage or severe injury.

**STEP 1:** Connect detergent injector to discharge nipple on machine. Connect high pressure hose to injector with quick coupler. (Check to make sure locking couplers are in proper position before applying water pressure).

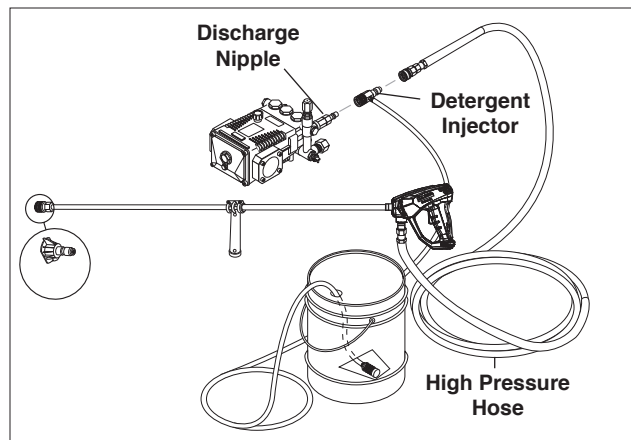

**STEP 2:** Use detergent designed specifically for pressure washers. Household detergents could damage the pump. Prepare detergent solution as required by the manufacturer. Fill a container with pressure washer detergent. Place the filter end of detergent suction tube into the detergent container.

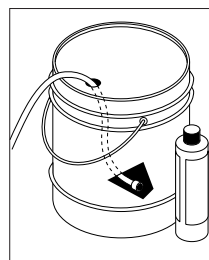

**STEP 3:** With safety latch on spray gun engaged, secure black detergent nozzle into quick coupler.

**NOTE:** Detergent cannot be applied using yellow, green or white nozzles.

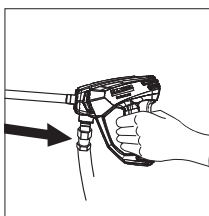

**STEP 4:** With the engine running, pull trigger to operate machine. Liquid detergent is drawn into the machine and mixed with water. Apply detergent to work area. Do not allow detergent to dry on surface.

**IMPORTANT:** You must flush the detergent injection system after each use by placing the suction tube into a bucket of clean water, then run the pressure washer in low pressure for 1-2 minutes.

## THERMAL PUMP PROTECTION

If you run the engine on your pressure washer for 1-2 minutes without pressing the trigger on the spray gun, circulating water in the pump can reach high temperatures. When the water reaches this temperature, the pump protector engages and cools the pump by discharging the warm water onto the ground. This thermal device prevents internal damage to the pump.

## CLEANING TIPS

Pre-rinse cleaning surface with fresh water. Place detergent suction tube directly into cleaning solution and apply to surface at low pressure (for best results, limit your work area to sections approximately 6 feet square and always apply detergent from bottom to top). Allow detergent to remain on surface 1-3 minutes. Do not allow detergent to dry on surface. If surface appears to be drying, simply wet down surface with fresh water. If needed, use brush to remove stubborn dirt. Rinse at high pressure from top to bottom in an even sweeping motion keeping the spray nozzle approximately 1 foot from cleaning surface. Use overlapping strokes as you clean and rinse any surface. For best surface cleaning action spray at a slight angle.

### Recommendations:

- Before cleaning any surface, an inconspicuous area should be cleaned to test spray pattern and distance for maximum cleaning results.
- If painted surfaces are peeling or chipping, use extreme caution as pressure washer may remove the loose paint from the surface.
- Keep the spray nozzle a safe distance from the surface you plan to clean. High pressure wash a small area, then check the surface for damage. If no damage is found, continue to pressure washing.

#### CAUTION - Never use:

- ⚠ Bleach, chlorine and other corrosive chemicals
- Liquids containing solvents (i.e., paint thinner, gasoline, oils)
- Tri-sodium phosphate products
- Ammonia products
- Acid-based products

These chemicals will harm the machine and will damage the surface being cleaned.

## RINSING

It will take a few seconds for the detergent to clear. Apply safety latch to spray gun. Remove black soap nozzle from the quick coupler. Select and install the desired high pressure nozzle. **NOTE:** You can also stop detergent from flowing by simply removing detergent siphon tube from bottle.

## SHUTTING DOWN AND CLEAN-UP

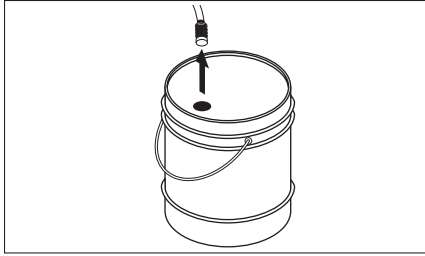

**STEP 1:** Remove detergent suction tube from container and insert into one gallon of fresh water. Slide nozzle forward for low pressure or to connect black detergent nozzle into wand quick coupler. Pull trigger on spray gun and siphon water for one minute.

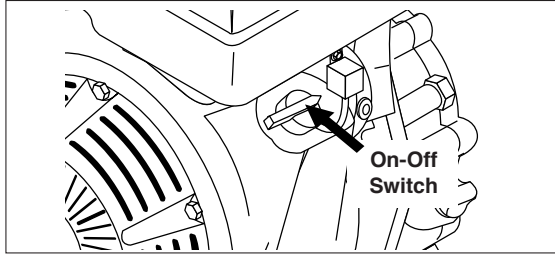

**STEP 2:** Turn off the engine.

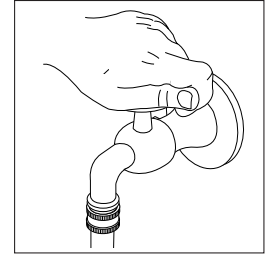

**STEP 3:** Turn off water supply.

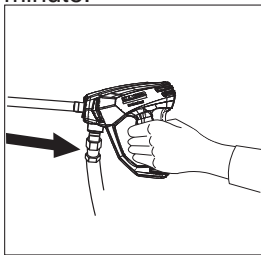

**STEP 4:** Press trigger to release water pressure.

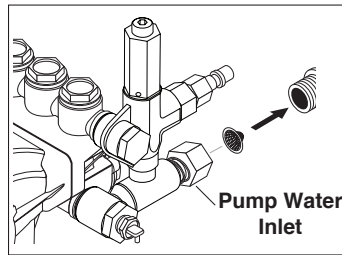

**STEP 5:** Disconnect the garden hose from the water inlet on the machine.

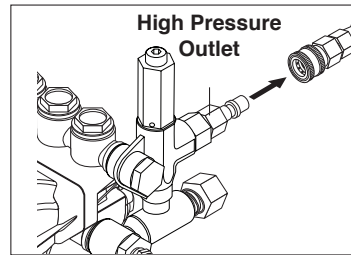

**STEP 6:** Disconnect the high pressure hose from high pressure outlet.

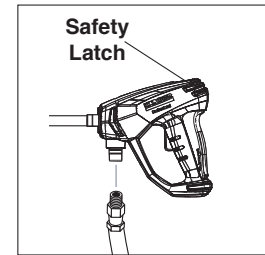

**STEP 7:** Engage the spray gun safety lock.

## STORAGE

**CAUTION:** Always store your pressure washer in a location where the temperature will not fall below 32°F (0°C). The pump in this machine is susceptible to permanent damage if frozen. **FREEZE DAMAGE IS NOT COVERED BY WARRANTY.**

1. Stop the pressure washer, squeeze spray gun trigger to release pressure.
2. Detach water supply hose and high pressure hose.
3. Turn on the machine for a few seconds, until remaining water exits. Turn engine off immediately.
4. Drain the gas and oil from the engine.
5. Do not allow high pressure hose to become kinked.
6. Store the machine and accessories in a room which does not reach freezing temperatures.

**CAUTION:** Failure to follow the above directions will result in damage to your pressure washer.

When the pressure washer is not being operated or is being stored for more than one month, follow these instructions:

1. Replenish engine oil to upper level.
2. Drain gasoline from fuel tank, fuel line, fuel valve and carburetor.
3. Pour about one teaspoon of engine oil through the spark plug hole, pull the starter grip several times and replace the plug. Then pull the starter grip slowly until you feel increased pressure which

indicates the piston is on its compression stroke and leave it in that position. This closes both the intake and exhaust valves to prevent rusting of cylinder.

4. Cover the pressure washer and store in a clean, dry place that is well ventilated away from open flame or sparks. **NOTE:** The use of a fuel additive, such as STA-BIL®, or an equivalent, will minimize the formulation of fuel deposits during shortage. Such additives may be added to the gasoline in the fuel tank of the engine, or to the gasoline in a storage container.

### After Extended Storage



**CAUTION:** Prior to restarting, thaw out any possible ice from pressure washer hoses, spray gun or wand.

### Engine Maintenance

During the winter months, rare atmospheric conditions may develop which will cause an icing condition in the carburetor. If this develops, the engine may run rough, lose power and may stall. This temporary condition can be overcome by deflecting some of the hot air from the engine over the carburetor area. **NOTE:** Refer to the engine manufacturer's manual for service and maintenance of the engine.

## TROUBLESHOOTING

PROBLEM	POSSIBLE CAUSE	SOLUTION
<b>LOW OPERATING PRESSURE</b>	Faulty pressure gauge	Install new gauge.
	Insufficient water supply	Use larger supply hose; clean filter at water inlet.
	Old, worn or incorrect spray nozzle	Match nozzle number to machine and/or replace with new nozzle.
	Belt slippage	Tighten or replace; use correct belt.
	Plumbing or hose leak	Check plumbing system for leaks. Re-tape leaks with teflon tape.
	Faulty or mis-adjusted unloader valve	Adjust unloader for proper pressure. Install repair kit when needed.
	Worn packing in pump	Install new packing kit.
	Fouled or dirty inlet or discharge valves in pump	Clean inlet and discharge valves.
	Worn inlet or discharge valves	Replace with valve kit.
	Obstruction in spray nozzle	Remove obstruction.
	Leaking pressure control valve	Rebuild or replace as needed.
	Slow engine RPM	Set engine speed at proper specifications.
	Pump sucking air	Check water supply and possibility of air seepage.
	Valves sticking	Check and clean or replace if necessary.
Unloader valve seat faulty	Check and replace if necessary.	
<b>FLUCTUATING PRESSURE</b>	Valves worn	Check and replace if necessary.
	Blockage in valve	Check and replace if necessary.
	Pump sucking air	Check water supply and air seepage at joints in suction line.
	Worn piston packing	Check and replace if necessary.

## ADJUSTING UNLOADER VALVES

Unloader valves are preset and tested at the factory before shipping. Occasional adjustment of the unloader may be necessary to maintain correct pressure.

Start with the valve set at its lowest spring tension. Raise pressure by turning adjusting knob clockwise until pressure is at the desired position. Do not overtighten.

Open and close spray gun to be sure pressure is correct. Raise or lower pressure by adjusting the knob.

Do not by-pass more than 1-2 minutes when by-passing to the suction side of the pump.



# EXPLODED VIEW - 1.575-152.0,154.0,155.0

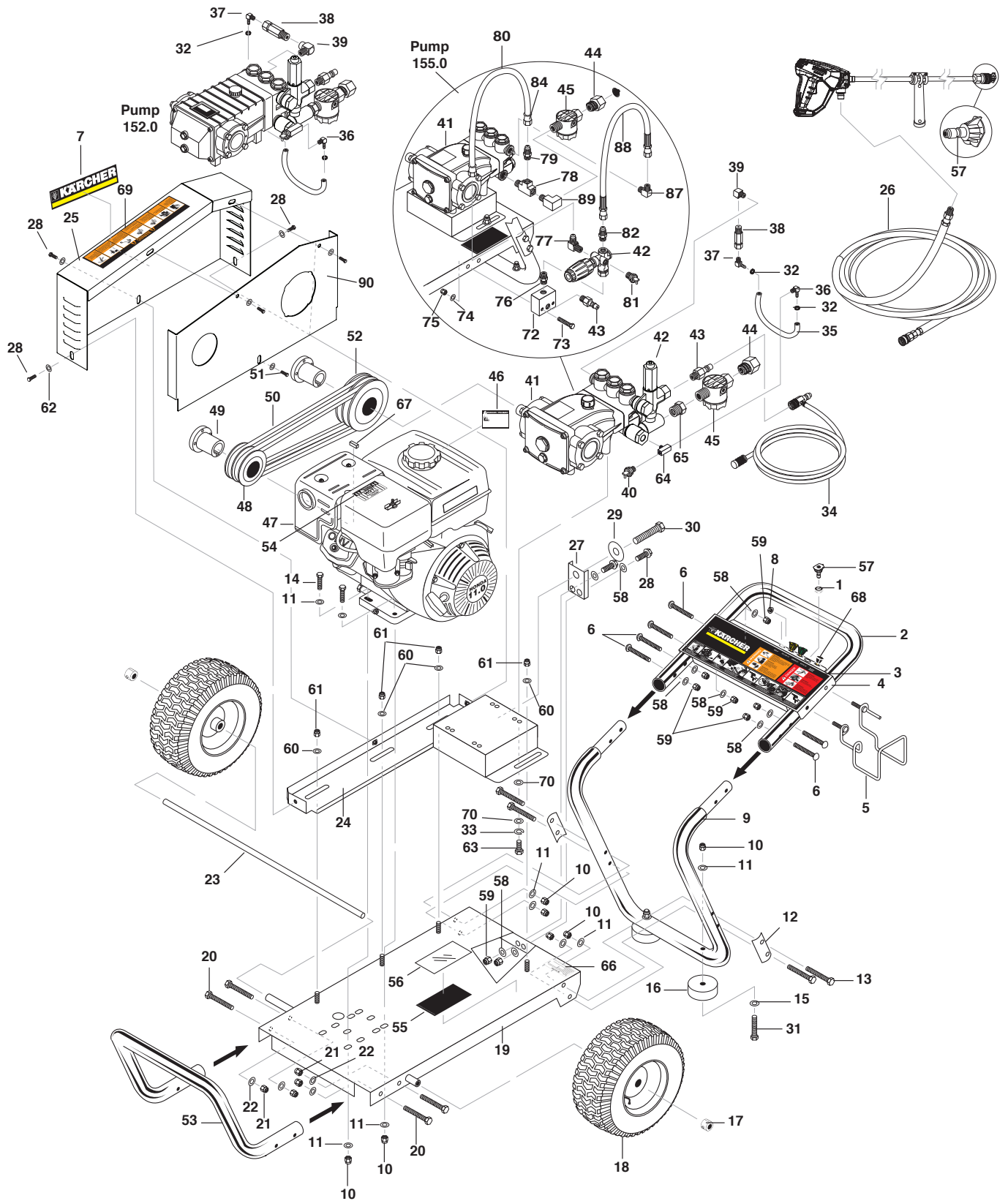

## EXPLODED VIEW PARTS LIST - 1.575-152.0,154.0,155.0

ITEM	PART NO.	DESCRIPTION	QTY	ITEM	PART NO.	DESCRIPTION	QTY
1	9.802-064.0	Grommet, Rubber, Nozzle Holder	5	37	8.706-955	Hose Barb, 1/4" Barb x 1/8" ML Pipe, 90° (All Except 155.0 & 154.0)	1
2	8.925-057.0	Handle, Grab, Grey, OS	1		8.706-940.0	Hose Barb, 1/4" Barb x 1/8" ML Pipe (154.0)	1
3	9.800-723.0	Label, Cold Water Handle	1	38	9.802-190.0	Valve, E-Z Start, 3/8" MPT x 1/8" FPT	1
4	9.803-126.0	Plate, Warning/Instruction, Black	1		9.804-065.0	Valve, E-Z Start, 1/4" MPT x 1/8" FPT (152.0)	1
5	9.803-098.0	Hanger, Hose/Wand	1	39	8.706-207.0	Elbow, 3/8", Street	1
6	9.802-706.0	Bolt, Carriage, 1/4"-20 x 1-3/4", Zinc	6		8.706-200.0	Elbow, 1/4", Street (152.0)	1
7	9.800-110.0	Label Karcher Logo	1	40	9.804-025.0	Pump Protector, 1/4"PTP (152.0)	1
8	9.802-778.0	Nut, 5/16" Whiz Loc Flange	2		8.707-256.0	Pump Protector, 1/2"PTP 140DEG, P/N 1005 (154.0)	1
9	8.925-058.0	Handle, Lower Grab, Grey, OS	1	41		Pump, See Specifications Pages	
10	9.197-003.0	Nut, 3/8" ESNA, NC	10	42		Unloader, See Specifications Pages	
11	9.802-807.0	Washer, 3/8" SAE, Flat	14	43	9.802-170.0	Coupler, 3/8"Plug, Female Steel/Zinc (152.0) Only	1
12	9.803-114.0	Retainer Bracket, Handle, Black	2	44	9.802-146.0	Swivel, 1/2" MP x 3/4" GHF w/Strainer	1
13	9.802-728.0	Bolt, 3/8" x 2" NC, HH	4	45	9.802-163.0	Strainer, 1/2" PA, Inline Plastic	1
14	9.802-727.0	Bolt, 3/8" x 1-3/4", Tap	4	46	9.800-008.0	Label, Danger Cool Engine	1
15	9.802-817.0	Washer, 3/8" x 1", Steel	2	47		Engine, See Specifications Pages	
16	9.802-066.0	Pad, Soft Rubber	2	48		Engine Pulley, See Specifications Pages	
17	9.802-782.0	Collar, 5/8" Bore Shaft, 3010	2	49		Engine Bushing, See Specifications Pages	
18	8.754-435.0	Wheel & Pu Tire Assy, 12" Steel Rim (152.0,154.0,155.0)	2	50		Belts, See Specifications Pages	
19	9.803-115.0	Frame Assy, Large, Black (152.0,154.0,155.0)	1	51		Pump Bushing, See Specifications Pages	
20	9.802-712.0	Bolt, 5/16" x 1-3/4", NC, Carriage, Zinc	4	52		Pump Pulley, See Specifications Pages	
21	9.802-776.0	Nut, 5/16", ESNA, NC	4	53	8.925-059.0	Handle, Bumper, Grey, OS	1
22	8.718-980.0	Washer, 5/16" Flat, SAE	4	54	9.800-006.0	Label, Hot/Caliente w/Arrows, Warning	1
23	8.911-226.0	Axle, 5/8" x 27" L (152.0,154.0,155.0)	1	55	8.932-968.0	Label, Intended For Outdoor Use	1
24	8.917-893.0	Assy Black, Slider Pump / Belt Guard Mount (152.0,154.0,155.0)	1	56	9.800-034.0	Label, Clear Lexan	1
25	8.917-886.0	Plate, Belt Guard Front Cover	1	57	8.712-338.0	Nozzle, SAQCMEG 1503.5, Yellow (152.0)	1
26		Hose and Spray Gun, See Assy Page			8.712-339.0	Nozzle, SAQCMEG, 2503.5, Green (152.0)	1
27	9.803-118.0	Bracket, Take Up, CW, Black	1		8.712-340.0	Nozzle, SAQCMEG 4003.5, White (152.0)	1
28	9.802-700.0	Screw, 1/4" x 3/4" HH NC	8		8.712-360.0	Nozzle, SAQCMEG 1504.0, Yellow (154.0)	1
29	9.802-809.0	Washer, 1/2", Flat, SAE	1		8.712-370.0	Nozzle, SAQCMEG, 2504.0, Green (154.0)	1
30	9.802-740.0	Bolt, 1/2" x 3-1/2" HEX	1		8.712-380.0	Nozzle, SAQCMEG 4004.0, White (154.0)	1
31	9.802-730.0	Bolt, 3/8" x 2-1/4", HH	2		8.712-333.0	Nozzle, SAQCMEG 1503.0, Yellow (155.0)	1
32	6.390-126.0	Clamp, Hose, .46-54 ST	2		8.712-334.0	Nozzle, SAQCMEG, 2503.0, Green (155.0)	1
33	9.802-813.0	Washer, 5/16" Lock (152.0)	4		8.712-335.0	Nozzle, SAQCMEG 4003.0, White(155.0)	1
	9.802-816.0	Washer, 7/16" Lock, Split (154.0,155.0)	4				
34	9.802-225.0	Injector Assy., Detergent, Non-Adj, 3-5 GPM, 0.083	1				
35	9.802-254.0	Hose, 1/4", Push-On, Fuel Line (All except 155.0)	1 ft.				
36	8.706-958.0	Barb, 1/4" Barb x 1/4" ML Pipe, 90° (All Except 155.0)	1				

## EXPLODED VIEW PARTS LIST - 1.575-152.0,154.0,155.0

ITEM	PART NO.	DESCRIPTION	QTY
58	9.802-802.0	Washer, 1/4" Flat	10
59	9.802-773.0	Nut, 1/4" ESNA	8
60	8.718-980.0	Washer, 5/16" Flat	4
61	9.802-776.0	Nut, 5/16" ESNA	4
62	9.802-802.0	Washer, 1/4" Flat, SAE	6
63	9.802-741.0	Bolt, 8mm x 16mm Hex (152.0)	4
	9.802-744.0	Bolt, 10mm x 20mm (154.0,155.0)	4
64	8.706-860.0	Tee, 1/2" Branch (155.0)	1
	8.706-854.0	Tee, 1/4" Branch (152.0)	1
65	8.706-984.0	Adapter, 1/2" x 1/2" (152.0)	1
66	9.800-049.0	Label, Manufacturer's Cleaning Solution	1
67	9.802-959.0	Key, .247 Sqr. x 2.125"	1
68	9.802-311.0	Nozzle, Compl., Detergent	1
69	9.800-036.0	Label, Warning, Pictoral, Small	1
70	8.718-980.0	Washer, 5/16" Flat (152.0)	4
	9.802-807.0	Washer, 3/8" Flat (155.0)	4
71	8.750-300.0	Unloader, VRT3 Ez Start (155.0)	1
72	9.802-870.0	Block, Unloader, 3/8" x 3/8" 1.25 Steel (155.0)	1
73	9.802-728.0	Bolt, 3/8" x 2", NC HH (155.0)	2
74	9.802-807.0	Washer, 3/8" SAE, Flat (155.0)	2
75	9.197-003.0	Nut, 3/8" ESNA NC (155.0)	2
76	8.705-974.0	Nipple, 3/8" Hex Steel (155.0)	1
77	9.802-129.0	Elbow, 3/8" x 1/2" JIC (155.0)	1
78	8.706-860.0	Street Tee, 1/2" (155.0)	1
79	9.802-128.0	Nipple, 1/2" x 1/2" JIC (155.0)	1
80	9.802-259.0	Hose, Push-on 1/2" (155.0)	15"
81	8.707-254.0	Pump Protector, 3/8" PTP (155.0)	1
82	9.802-036.0	Nipple, 1/2" JIC, 3/8" Pipe (155.0)	1
83	9.802-810.0	Washer, 5/8" Flat	2
84	9.802-151.0	Swivel, 1/2" JIC, Female, Push-On (155.0)	2
85	9.802-959.0	Key, .247" Sqr. x 2.125"	1
86	9.800-036.0	Label, Warning, Pictoral, Small	1
87	9.802-039.0	Elbow, 1/2" JIC, 3/8", 90° (155.0)	1
88	8.918-422.0	Hose, 3/8" x 20", 2 Wire, Pressure Loop (155.0)	1
89	8.706-829.0	Elbow, 1/2" Street, Brass	1
90	8.917-889.0	Plate, Belt Guard Back Cover	1
	8.920-542.0	Black Plate Belt Guard (152.0)	1

□ Not Shown



## SPECIFICATIONS

Model	GPM	Pressure (PSI)	Nozzle Size	Pump	Pump Part No.	Unloader Part No.	Engine	Engine Part No.	Pump Pulley	Pump Pulley Part No.
1.575-152.0	3.0	3000	3.5	KB3030R	8.923-781.0	8.923-921.0	GX270 (270cc)	8.750-680.0	2BK80	9.802-389.0
1.575-154.0	3.7	3500	4.0	KM4035R.3	8.751-189.0	9.175-018.0	GX390 (390cc)	8.750-580.0	2BK90H	8.715-593.0
1.575-155.0	3.0	4000	3.0	KM3540R.3	8.751-186.0	8.750-300.0	GX390 (390cc)	8.750-580.0	2BK80H	9.802-389.0

## SPECIFICATIONS

Model	Pump Bushing	Bushing Part No.	Engine Pulley	Pulley Part No.	Engine Bushing	Bushing Part No.	Belt Size	Belt Part No.
1.575-152.0	24MM	9.802-402.0	2BK40H	9.802-384.0	HX1"	9.802-398.0	BX38 (2)	9.802-417.0
1.575-154.0	24MM	9.802-402.0	2BK32H	9.802-381.0	HX1"	9.802-398.0	BX39 (2)	9.802-418.0
1.575-155.0	24MM	9.802-402.0	2BK40H	9.802-384.0	HX1"	9.802-398.0	BX38 (2)	9.802-417.0

# HOSE & SPRAY GUN ASSEMBLY

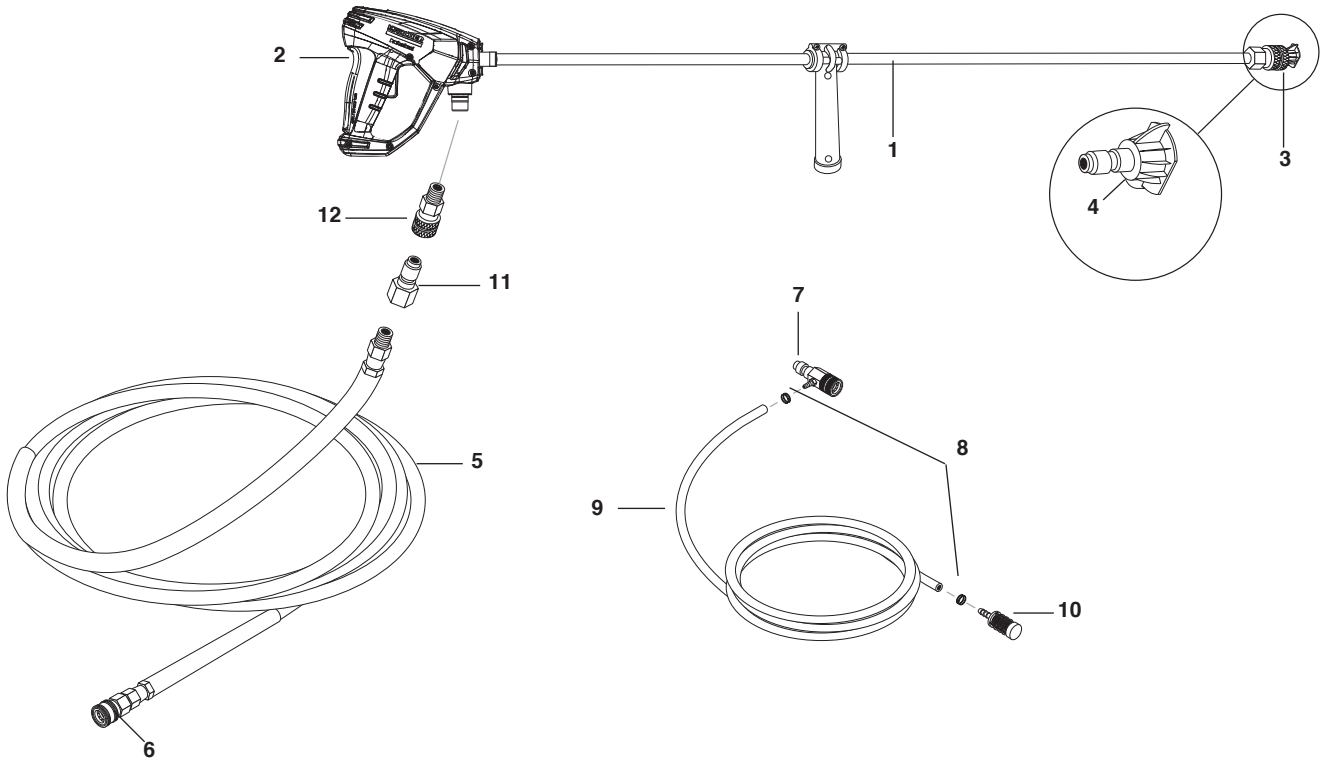

## HOSE & SPRAY GUN ASSEMBLY PARTS LIST

ITEM	PART NO.	DESCRIPTION	QTY
1	9.802-219.0	Wand Assy., Side Grip w/1/4" Coupler, 35-1/2"	1
2	4.775-054.0	EASYForce Advanced KNA	1
3	9.802-164.0	Coupler, 1/4" Female, Brass	1
4		Nozzle, See Breakdown for Part Numbers	
5	8.925-130.0	Hose, 3/8" X 50' 1W 4000PSI SW/SO/CPL (150.0, 151.0, 152.0)	1
	8.925-132.0	Hose, 3/8" X 50' 2W 6000PSI SW/SO/CPL (154.0, 155.0)	1
6	9.802-166.0	Coupler, 3/8" Female, Brass	1
7	9.802-216.0	Injector, Chemical, Non-Adjust, 3-5 GPM, .083	1
8	6.390-126.0	Clamp, Hose	2
9	9.802-251.0	Tube, 1/4" x 1/2" Clear Vinyl	6 ft.
10	8.707-057.0	TStrainer, Plastic, 1/4" Hose Barb	1
11	9.802-170.0	Nipple 3/8 x 3/8 NPT Fem (155.0 Only)	1
12	9.802-169.0	Coupler 3/8" Male Brass (155.0 Only)	1

# VTR3 UNLOADER EXPLODED VIEW AND PARTS LIST

8.750-300.0, 8 GPM, 4500 PSI EZ Start

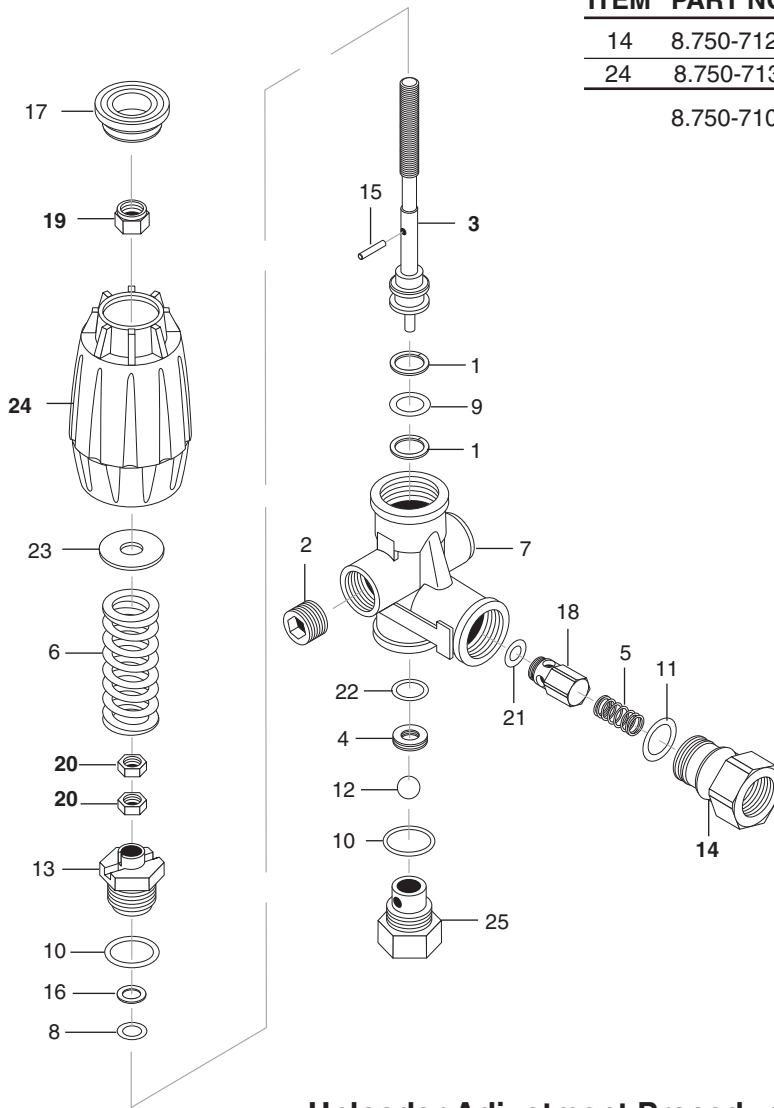

ITEM	PART NO.	DESCRIPTION	QTY
14	8.750-712.0	Outlet Fitting	1
24	8.750-713.0	Knob, Unloader	1
8.750-710.0 Repair Kit, VRT3, 4500 PSI			
(Kit Items: 1, 4, 8-12, 16, 21-22)			

## Unloader Adjustment Procedures

1. Remove lock nut (Item 19).
2. Remove adjustment knob (Item 24).
3. Loosen the two (2) nuts (Item 20), move them upward on stem (Item 3) until you see 4 or more threads below the nut.
4. Re-attach adjusting knob (Item 24).
5. Start machine. Open the trigger of the spray gun. Increase pressure by turning adjustment knob (Item 24) clockwise until pressure is at the desired operating pressure.
6. Remove the adjustment knob (Item 24), tighten the lower nut (Item 20) tightly against the upper nut (Item 20). Re-attach adjustment knob (Item 24) and screw down until contact is made with the nuts (Items 20). Screw down lock nut (Item 19) onto the stem (Item 3) until the threads cut into the nylon insert of the lock nut (Item 19).

\*If adjustment knob (Item 24) **DOES NOT** make contact with upper nut (Items 20), remove adjusting knob (Item 24), re-adjust (raise) nuts (Items 20) on stem (Item 3) and re-attach adjustment knob (Item 24), then repeat step #6.

\*\*If adjustment knob (Item 24) **DOES** make contact with upper nut; release the trigger of the spray gun and watch the pressure gauge for the pressure increase ("spike"). This "spike" **SHOULD NOT** exceed 500 psi above the operating pressure. If "spike" pressure exceeds the 500 psi limit, remove the adjusting knob (Item 24) and re-adjust (lower) the nuts (Items 20) on the stem (Item 3). Re-attach the adjusting knob (Item 24), then repeat step #6.

## UU1 UNLOADER EXPLODED VIEW

9.175-018.0  
 UU1 3500PSI, UNIVERSAL UNLOADER (SPARE)

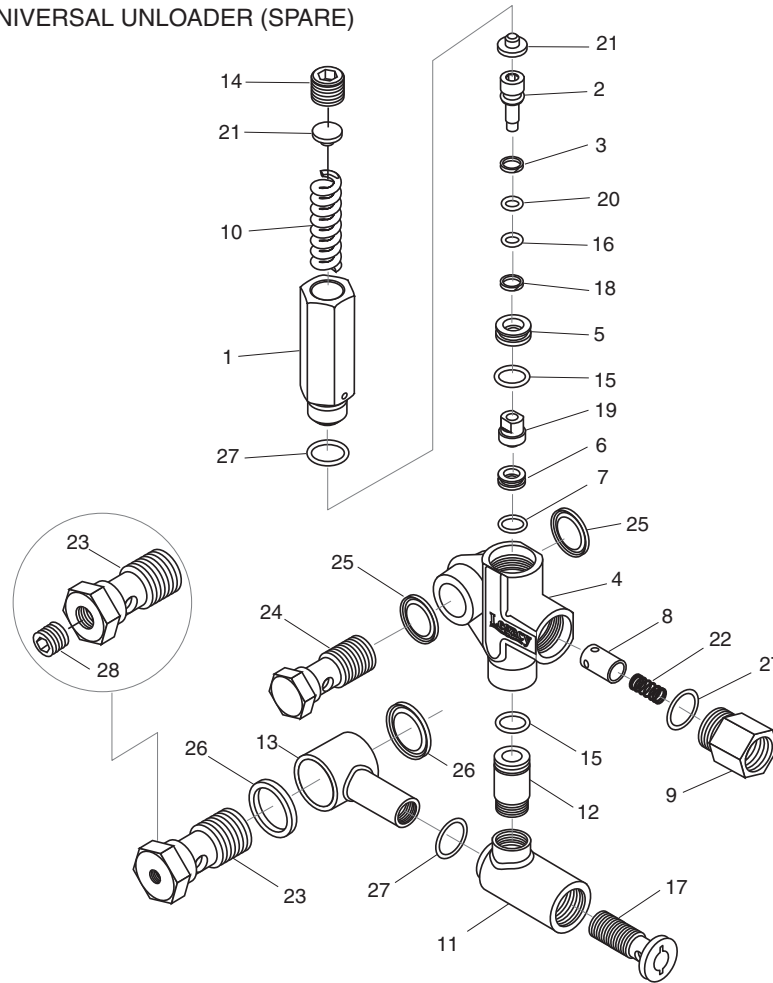

### UU1 UNLOADER EXPLODED VIEW PARTS LIST

ITEM	PART #	DESCRIPTION	KIT	QTY	ITEM	PART #	DESCRIPTION	KIT	QTY
1	8.751-394.0	Piston Housing	D	1	17	9.149-006.0	Sliding Connector Guide		1
2		Piston	C, D	1	18		O-Ring Backup 6 x 1.45 x 1.68	A, D	1
3		Piston O-Ring Back Up	A, D	1	19		Ball Housing Assy	C, D	1
4	8.749-796.0	Main Block		1	20		O-Ring 6.75 x 1.78 BN80	A, D	1
5	9.152-372.0	Piston Ring	D	1	21		Spring Seat	C, D	2
6		Ball Seat	C, D	1	22		Plunger Spring	B	1
7		O-Ring 10.5 ID x 1.5 CS	A,C,D	1	23	8.917-699.0	Banjo Bolt 1/2" Short		1
8		Plunger	B	1		8.917-700.0	Banjo Bolt 1/2"-1/4" NPT Short		1
9	9.152-016.0	Plunger Housing		1	24	8.917-698.0	Banjo Bolt 3/8" Short		1
10		Bypass Spring	C, D	1	25	9.802-893.0	Seal Washer 3/8"		2
11	9.149-001.0	Low Pressure Port		1	26	9.803-921.0	Seal Washer 1/2"		2
12	9.152-017.0	Sliding Connector, 30mm		1		9.802-893.0	Seal Washer 3/8"		2
	8.762-005.0	Sliding Connector, 40mm, Long		1	27		O-Ring 15 ID x 2CS	A,B,D	3
13	9.149-002.0	Sliding Connector H 1/2"		1	28	8.706-865.0	Plug, 1/4" Countersunk		1
	9.149-005.0	Sliding Connector H 3/8"		1	<b>Kit A</b>	9.104-038.0	O-Ring Repair Kit		
14	9.196-011.0	Plug 5/8 -18 UNF	D	1	<b>Kit B</b>	9.104-039.0	Outlet Kit		
15		O-Ring 12 ID x 2 CS	A, D	2	<b>Kit C</b>	9.104-040.0	Stem Basic Kit		
16		O-Ring 6 ID X 2 CS	A, D	1	<b>Kit D</b>	8.920-045.0	UU1 Complete Stem Kit		

## VBT UNLOADER EXPLODED VIEW

8.754-696.0  
UNLOADER, VBT BANJO 1/2M 3/8M, 3000PSI

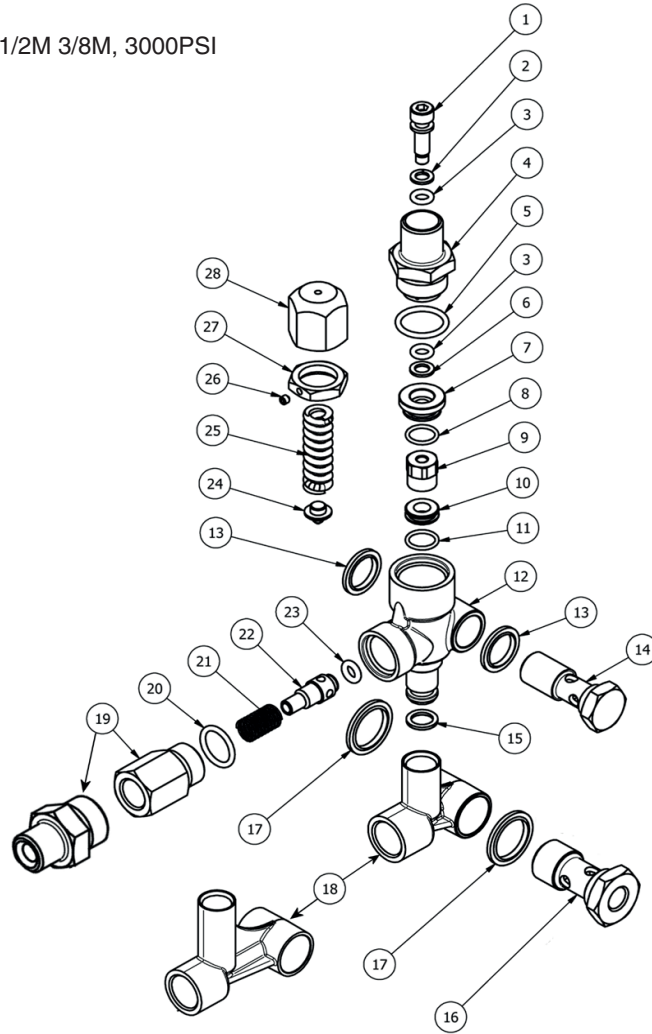

### VBT UNLOADER EXPLODED VIEW PARTS LIST

ITEM	PART #	DESCRIPTION	KIT	QTY	ITEM	PART #	DESCRIPTION	KIT	QTY
1*	8.754-929.0	Stem	C	1	17	9.803-914.0	Seal Washer 1/2)		1
2*	9.803-912.0	Backup Ring	A	1	18	8.754-937.0	Bypass Manifold		1
3*	8.754-930.0	O-ring, Ø2.62 x 6.02	A	2	19	9.802-892.0	Outlet Connector 3/8 MPT		1
4	8.730-882.0	Stem Connector		1	20*	9.803-191.0	O-ring, Ø2.62 X 17.13	A,B	1
5*	9.803-193.0	O-ring, Ø2.62 x 20.24	A	1	21*	8.933-017.0	Poppet Spring	B	1
6*	9.803-908.0	Backup Ring	A	1	22*	8.754-939.0	Poppet	B	1
7	9.803-907.0	Guide Bushing		1	23*	8.754-940.0	O-ring, Ø3 x 6	A,B	1
8*	9.803-906.0	O-ring, Ø1.78 x 14	A	1	24*	8.754-961.0	Plate	C	1
9*	8.754-959.0	Ball SubAssembly	C	1	25*	8.933-018.0	Spring 1500-4000 PSI	C	1
10*	8.754-933.0	Seat	C	1	26	8.933-021.0	Set Screw		1
11*	8.754-934.0	O-ring, Ø1.78 x 12.42	A,C	1	27	9.803-925.0	Nut		1
12	8.754-935.0	Valve Body		1	28	9.803-926.0	Knob, Brass, Unloader		1
13	9.802-893.0	Seal Washer 3/8		1					
14	9.803-919.0	Banjo Bolt 3/8		1					
15*	8.754-936.0	O-ring, Ø2.62 x 10.78	A	1					
16	9.803-920.0	Banjo Bolt, 1/2, w/1/4" Port		1					

\* Included in Kit

**Kit A** 8.754-941.0 O-Ring Repair Kit  
**Kit B** 8.754-942.0 Outlet Repair Kit  
**Kit C** 8.754-957.0 Stem Repair Kit

## KM.3 SERIES PUMP EXPLODED VIEW

8.751-189.0 KM4035R.3  
8.751-186.0 KM3540R.3

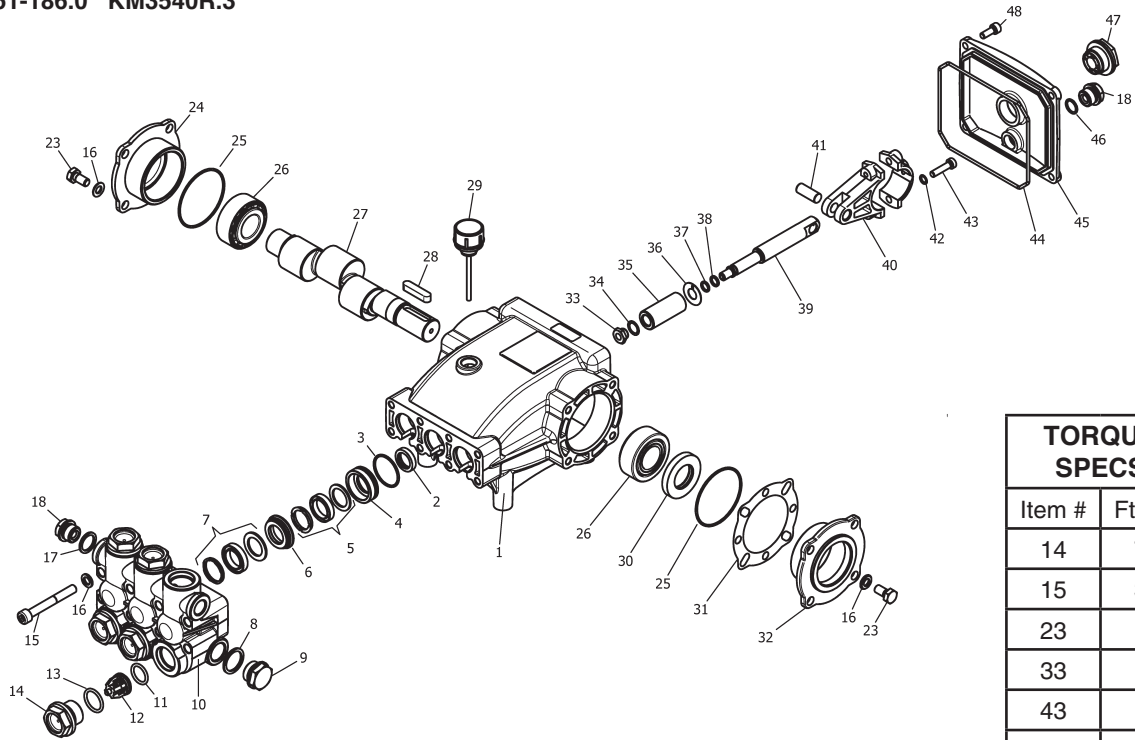

TORQUE SPECS	
Item #	Ft.-lbs
14	75
15	30
23	8
33	9
43	13
48	7.6

### KM.3 SERIES PUMP EXPLODED VIEW PARTS LIST

ITEM	PART NO.	DESCRIPTION	QTY	ITEM	PART NO.	DESCRIPTION	QTY
1	8.751-216.0	Crankcase	1	23	9.802-944.0	Hexagonal Screw	8
2*	See Kits Below	Plunger Oil seal	3	24	8.717-210.0	Closed Bearing Housing	1
3*	See Kits Below	O-Ring Ø1.78 x 31.47	3	25	9.803-192.0	O-Ring Ø1.78 x 60.05	2
4*	See Kits Below	Pressure Ring	3	26	8.933-011.0	Tapered Roller Bearing	2
5*	See Kits Below	U-Seal	3	27	9.803-146.0	Crankshaft (3540)	1
6*	See Kits Below	Intermediate Ring	3		9.803-147.0	Crankshaft (4035)	1
7*	See Kits Below	U-Seal	3	28	9.803-167.0	Crankshaft Key	1
8	9.803-199.0	Washer, Copper	1	29	9.802-921.0	Oil Dip Stick	1
9	9.802-926.0	Plug, Brass 1/2	1	30	9.803-140.0	Crankshaft Seal	1
10	8.751-218.0	Manifold Head	1	31	9.803-178.0	Shim	2
11*	See Kits Below	O-Ring Ø2.62 x 17.13	6	32	8.717-209.0	Bearing Housing	1
12*	See Kits Below	Valve Assembly	6	33*	See Kits Below	Plunger Nut, M8	3
13*	See Kits Below	O-Ring Ø2.62 x 20.29	6	34*	See Kits Below	Copper Spacer	3
14	9.802-928.0	Valve Plug	6	35*	See Kits Below	Plunger (4035) Plunger (3540)	3 3
15	9.802-938.0	Manifold Stud Bolt	8	36*	See Kits Below	Copper Spacer	3
16	9.802-884.0	Washer	16	37*	See Kits Below	O-Ring Ring	3
17	9.803-198.0	Copper Washer 3/8	1	38*	See Kits Below	Teflon Ring	3
18	9.802-925.0	Brass Plug 3/8	2	39	9.803-144.0	Plunger Rod	3

## KM.3 SERIES PUMP EXPLODED VIEW PARTS LIST (CONT.)

ITEM	PART NO.	DESCRIPTION	QTY
40	9.803-158.0	Connecting Rod	3
41	8.751-228.0	Connecting Rod Pin	3
42	9.803-218.0	Spring Washer	6
43	9.803-238.0	Connecting Rod Screw	6
44	70-060009	O-Ring, Ø2.62 x 126.67	1
45	8.751-229.0	Crankcase Cover	1
46	9.803-197.0	O-Ring, Ø1.78 x 14	1
47	9.803-202.0	Sight Glass 3/4	1
48	9.802-939.0	Cover Screw	5

\* Available in kit (See below)

REPAIR KIT NO.	8.725-360.0	8.725-358.0	8.725-361.0	8.725-359.0	8.725-237.0	8.933-023.0	9.802-603.0	9.802-609.0
KIT DESCRIPTION	Plunger Seal 4035 18mm	Plunger Seal 3540 15mm	Complete Seal Packing 4035 18mm	Complete Seal Packing 3540 15mm	Plunger 4030 18mm	Plunger 3540 15mm	Complete Valve	Plunger Oil Seals
ITEM NUMBERS INCLUDED	3, 5, 7	3, 5, 7	3, 4, 5, 6, 7	3, 4, 5, 6, 7	33, 34, 35, 36, 37, 38	33, 34, 35, 36, 37, 38	11, 12, 13	2
NO. OF CYLINDERS KIT WILL SERVICE	3	3	1	1		1	6	3



# KB3030R SERIES PUMP EXPLODED VIEW

8.923-781.0 KB3030R

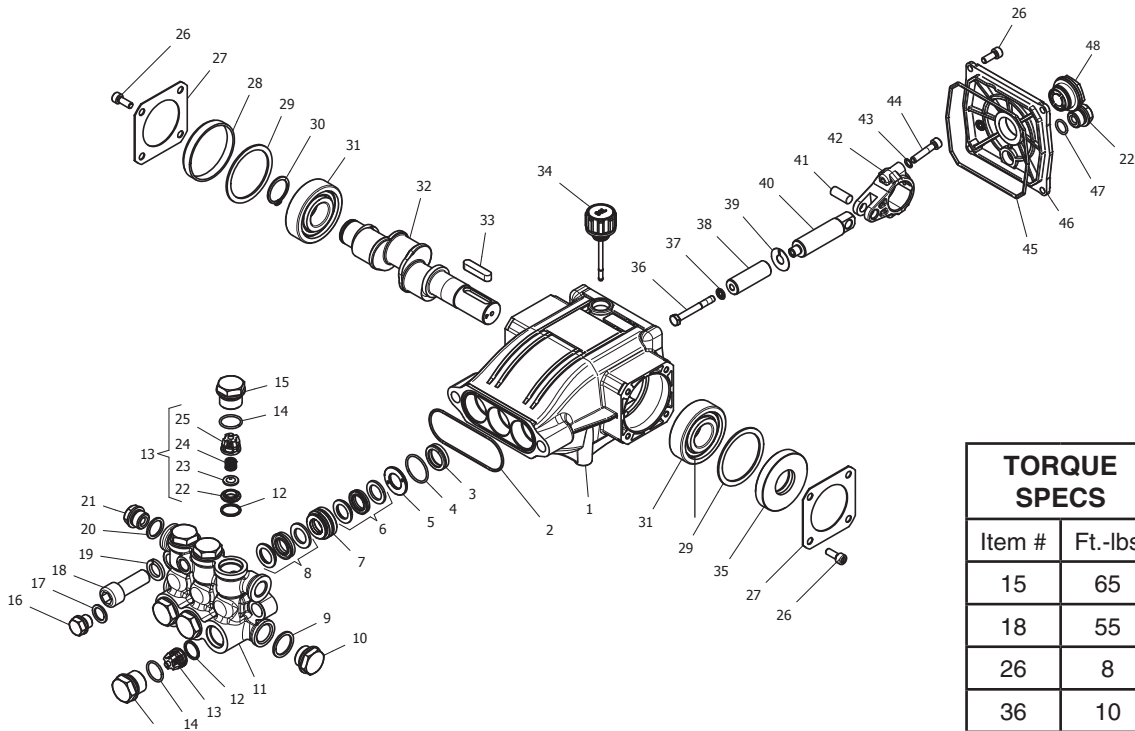

TORQUE SPECS	
Item #	Ft.-lbs
15	65
18	55
26	8
36	10
44	10

## KB3030R SERIES PUMP EXPLODED VIEW PARTS LIST

ITEM	PART NO.	DESCRIPTION	QTY	ITEM	PART NO.	DESCRIPTION	QTY
1	8.754-841.0	Crankcase	1	20	9.803-198.0	Washer, Copper G3/8	1
2	8.754-846.0	O-ring Ø1.78 X 72.75	1	21	8.707-262.0	Plug, Brass G3/8	2
3*	See Kits Below	Plunger Oil Seal	3	22*	See Kits Below	Valve Seat	6
4*	See Kits Below	O-ring Ø1.78 X 26.7	3	23*	See Kits Below	Valve Plate	6
5*	See Kits Below	Washer, Pressure Ring 16 mm	3	24*	See Kits Below	Valve Spring	6
6*	See Kits Below	U-Seal, 16 mm	3	25*	See Kits Below	Valve Cage	6
7*	See Kits Below	Pressure Ring, 16 mm	3	26	9.802-939.0	Screw, M6 X 16	12
8*	9.803-199.0	U-Seal, 16 mm	3	27	8.717-137.0	Bearing Cover	2
9	9.803-199.0	Washer, Copper G1/2	1	28	9.803-954.0	Bearing Seal	1
10	9.802-926.0	Plug, Brass G1/2	1	29	8.754-843.0	Seal Spacer, Crankshaft	2
11	8.754-852.0	Manifold	1	30	9.802-914.0	Snap Ring, 25 mm	1
12*	8.717-233.0	O-ring Ø1.78 X 15.6	6	31	9.803-955.0	Bearing, Ball	2
13*	See Kits Below	Valve Assembly	6	32	8.754-829.0	Shaft, 24 mm 3030	1
14*	9.803-948.0	O-ring Ø1.78 X 18.77	6		8.754-830.0	Shaft, 24 mm 4025	1
15	9.803-949.0	Valve Plug	6	33	9.803-167.0	Key, Crankshaft	1
16	8.754-851.0	Plug, Brass G1/4	1	34	8.754-219.0	Oil Dipstick	1
17	8.718-973.0	Washer, Copper G1/4	1	35	8.933-010.0	Seal, Crankshaft	1
18	8.754-854.0	Bolt, Manifold M14 X 40	2				
19	8.754-850.0	Washer, Lock	2				

## KB3030R SERIES PUMP EXPLODED VIEW PARTS LIST

ITEM	PART NO.	DESCRIPTION	QTY
36*	8.754-855.0	Bolt, Plunger	3
37*	8.754-092.0	Spacer, Copper	3
38*	8.754-848.0	Plunger, 16 mm	3
39*	9.803-962.0	Spacer, Copper	3
40	8.754-827.0	Plunger Rod	3
41	9.803-965.0	Connecting Rod Pin	3
42	9.803-966.0	Connecting Rod	3
43	9.803-218.0	Washer, 6 mm	6
44	8.933-020.0	Screw, Connecting Rod	6
45	8.754-847.0	O-ring Ø2.62 X 111.62	1
46	8.754-842.0	Cover, Crankcase	1
47	9.803-906.0	O-ring Ø1.78 X 14	1
48	9.803-202.0	Sight Glass, G3/4	1

\* Available in kit (See below)

REPAIR KIT NUMBER	8.754-856.0	8.754-857.0	8.754-858.0	8.754-859.0	9.803-937.0
Kit Description	Plunger Seal 16mm	Steel Packing 16mm	Pluger 16 mm	Complete Valve	Plunger Oil Seals
ITEM NUMBERS INCLUDED	4, 6, 8	4, 5, 6, 7, 8	36, 37, 38, 39	12, 13, 14	3
NUMBER OF CYLINDERS KIT WILL SERVICE	3	1	1	6	3





**THANK YOU!**  
**MERCI! DANKE! ¡GRACIAS!**



Registrieren Sie Ihr Produkt und profitieren Sie von vielen Vorteilen.

Register your product and benefit from many advantages.

Enregistrez votre produit et bénéficiez de nombreux avantages.

Registre su producto y aproveche de muchas ventajas.

**[www.kaercher.com/welcome](http://www.kaercher.com/welcome)**



Bewerten Sie Ihr Produkt und sagen Sie uns Ihre Meinung.

Rate your product and tell us your opinion.

Évaluer votre produit et dites-nous votre opinion.

Reseñe su producto y díganos su opinión.

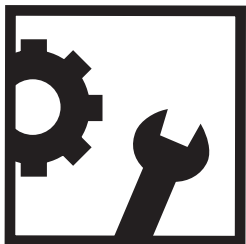

**[www.kaercher.com/dealersearch](http://www.kaercher.com/dealersearch)**

**Alfred Kärcher SE & Co. KG**  
Alfred-Kärcher-Str. 28-40  
71364 Winnenden (Germany)  
Tel.: +49 7195 14-0  
Fax: +49 7195 14-2212

