



## MODEL 871SS

### OPERATING INSTRUCTIONS AND PARTS MANUAL

*Thank you for purchasing a Hotsy Pressure Washer. This manual covers the operation and maintenance of your pressure washer. All information in this manual is based on the latest product information available at the time of printing. Hotsy, Inc. reserves the right to make changes at any time without incurring any obligation.*

*Read instructions carefully before attempting to assemble, install, operate or service this pressure washer. Failure to comply with instructions could result in personal injury and/or property damage!*



**SERIAL NUMBER:**

**DATE PURCHASED:**

**FOR SALES AND SERVICE, PLEASE CONTACT:**

**SHOP PRESSURE  
WASHER PARTS**

**shoppressurewasherparts.com | (888) 269-0172**



---

## **871SS SPECIFICATIONS**

---

- Pump Volume At Pump Head: 2.71 GPM/162.6 GPH
- Pump Pressure At Pump Head: 2400 PSI
- Burner Type: Fuel Oil Fired, 248,500 BTU/Hr.
- Burner Fuel Pressure: 205 PSI Max.
- Machine Model: GX200 HONDA
- Machine Weight: 291 Lbs.
- Shipping Weight: 330 Lbs.
- Exhaust Stack Size: 8"
- Machine Dimensions: Length=48", Width=27", Height=42.5"

# CONTENTS

---

Introduction & Important Safety Information	5-7
Component Identification	8
Assembly Instructions	9
Installation Instructions	10-11
Operating Instructions	12-13
Storage	13-14
Maintenance	15
Troubleshooting	16-17
Exploded Views	18-19
Exploded View, Parts List	20
Burner Assembly & Parts List	21
Control Box Assembly & Parts List	22
Coil Outlet Assembly & Parts List	23
Hose & Spray Gun Assembly & Parts List	23
VBT Unloader Valve Exploded View & Parts List	24
Pump Assemblies & Parts Lists	25
Pump Exploded Views & Parts Lists	26-27
Burner Exploded View and Parts List	28-29
Wiring Diagram	30

Model Number \_\_\_\_\_

Serial Number \_\_\_\_\_

Date of Purchase \_\_\_\_\_

The model and serial numbers will be found on a decal attached to the pressure washer. You should record both serial number and date of purchase and keep in a safe place for future reference.

## INTRODUCTION & IMPORTANT SAFETY INFORMATION

Thank you for purchasing this Pressure Washer.

We reserve the right to make changes at any time without incurring any obligation.

### Owner/User Responsibility:

The owner and/or user must have an understanding of the manufacturer's operating instructions and warnings before using this pressure washer. Warning information should be emphasized and understood. If the operator is not fluent in English, the manufacturer's instructions and warnings shall be read to and discussed with the operator in the operator's native language by the purchaser/owner, making sure that the operator comprehends its contents.

Owner and/or user must study and maintain for future reference the manufacturers' instructions.

The operator must know how to stop the machine quickly and understand the operation of all controls. Never permit anyone to operate the engine without proper instructions.

### SAVE THESE INSTRUCTIONS

This manual should be considered a permanent part of the machine and should remain with it if machine is resold.

When ordering parts, please specify model and serial number. Use only identical replacement parts. This machine is to be used only by trained operators.

## IMPORTANT SAFETY INFORMATION

**! WARNING**



READ OPERATOR'S MANUAL THOROUGHLY PRIOR TO USE.

**WARNING:** To reduce the risk of injury, read operating instructions carefully before using.

**AVERTISSEMENT :** Pour réduire le risque de blessures, lire attentivement les instructions de fonctionnement avant l'utilisation.

1. Read the owner's manual thoroughly. Failure to follow instructions could cause malfunction of the machine and result in death, serious bodily injury and/or property damage.

**! WARNING**



KEEP WATER SPRAY AWAY FROM ELECTRICAL WIRING.

2. Know how to stop the machine and bleed pressure quickly. Be thoroughly familiar with the controls.

3. Stay alert — watch what you are doing.

**WARNING:** Keep wand, hose, and water spray away from electric wiring or fatal electric shock may result.

**AVERTISSEMENT :** Garder la lance, le boyau et le jet d'eau à l'écart de tout câblage électrique ou des chocs électriques mortels pourraient survenir.

4. All installations must comply with local codes. Contact your electrician, plumber, utility company or the selling distributor for specific details.

**! WARNING**



EAR PROTECTION MUST BE WORN

**WARNING:** This machine exceeds 85 db appropriate ear protection must be worn.

**AVERTISSEMENT :** Cette machine excède 85 dB et une protection de l'ouïe appropriée doit être portée.

**! WARNING**



USE PROTECTIVE EYE WEAR AND CLOTHING WHEN OPERATING THIS EQUIPMENT.

**WARNING:** High pressure spray can cause paint chips or other particles to become airborne and fly at high speeds. To avoid personal injury, eye, hand and foot safety devices must be worn.

**AVERTISSEMENT :** Un jet haute pression peut écailler la peinture ou provoquer l'émission d'autres particules dans l'air et leur projection à hautes vitesses. Afin d'éviter des blessures personnelles, des dispositifs de sécurité pour les yeux, les mains et les pieds doivent être portés.

5. Eye, hand, and foot protection must be worn when using this equipment.

5. Eye, hand, and foot protection must be worn when using this equipment.

6. Keep operating area clear of all persons.

**WARNING:** Flammable liquids can create fumes which can ignite, causing property damage or severe injury.

**! WARNING**



RISK OF EXPLOSION: OPERATE ONLY WHERE OPEN FLAME OR TORCH IS PERMITTED

**AVERTISSEMENT:** Des liquides inflammables peuvent produire des vapeurs qui peuvent s'enflammer, causant ainsi des dommages à la propriété ou des blessures graves.

**WARNING:** Risk of explosion — Operate only where open flame or torch is permitted.

**AVERTISSEMENT :** Risque d'explosion — utiliser uniquement dans des endroits où l'utilisation d'une flamme nue ou d'une torche est permise.

**! WARNING**



RISK OF FIRE. DO NOT ADD FUEL WHEN OPERATING MACHINE.

**WARNING:** Risk of fire — Do not add fuel when the product is operating or still hot.

**AVERTISSEMENT :** Risque d'incendie — ne pas ajouter de carburant pendant que la machine fonctionne ou est encore chaude.

## IMPORTANT SAFETY INFORMATION



**WARNING:** Do not use gasoline crankcase draining or oil containing gasoline, solvents or alcohol. Doing so will result in fire and/or explosion.

**AVERTISSEMENT :** Ne pas utiliser de carburant, de drainage du carter de moteur ou de carburant contenant de l'huile, de solvants ou de l'alcool. Cela risquerait de causer un incendie et une explosion.

**WARNING:** Risk of fire — Do not Spray flammable liquids.

**AVERTISSEMENT :** Risque d'incendie – ne pas pulvériser de liquides inflammables.

**WARNING:** This product contains chemicals known to the state of California to cause cancer and birth defects or other reproductive harm. Operation of this equipment may create sparks that can start fires around dry vegetation. A spark arrestor may be required. The operator should contact: Local fire agencies for laws or regulations relating to fire prevention requirements.

**AVERTISSEMENT :** Ce produit contient des produits chimiques reconnus dans l'État de la Californie comme causant le cancer, des anomalies congénitales ou d'autres problèmes liés à la reproduction. Le fonctionnement de cet équipement peut produire des étincelles qui peuvent être la cause d'un début d'incendie dans des endroits de végétation sèche. Un pare-étincelles peut être requis. L'opérateur doit contacter : Les agences locales de services d'incendie en ce qui concerne les lois et réglementations relatives à la prévention des incendies.

7. Allow engine to cool for 1-2 minutes before refueling. If any fuel is spilled, make sure the area is dry before testing the spark plug or starting the engine. (Fire and/or explosion may occur if this is not done.) Gasoline engines on mobile or portable equipment shall be refueled:
  - a. outdoors;
  - b. with the engine on the equipment stopped;
  - c. with no source of ignition within 10 feet of the dispensing point; and
  - d. with an allowance made for expansion of the fuel should the equipment be exposed to a higher ambient temperature.

In an overfilling situation, additional precautions are necessary to ensure that the situation is handled in a safe manner.

**WARNING:** Risk of injury. Disconnect battery ground terminal before servicing.

**AVERTISSEMENT:** Risque de blessures. Débrancher la borne de mise à la terre de la batterie avant de procéder à des opérations d'entretien.

8. When in use, do not place machine near flammable objects as the engine is hot.
9. Oil burning appliances shall be installed only in locations where combustible dusts and flammable gases or vapors are not present. Do not store or use gasoline near this machine.
10. Use No. 1 or No. 2 heating oil (ASTM D306) only. **NEVER** use gasoline in your fuel oil tank. Gasoline is more combustible than fuel oil and could result in a serious explosion. **NEVER** use crankcase or waste oil in your burner. Fuel unit malfunction could result from contamination.
11. Do not confuse gasoline and fuel oil tanks. Keep proper fuel in proper tank.



**WARNING:** Risk of injury. Hot surfaces can cause burns. Use only designated gripping areas of spray gun and wand. Do not place hands or feet on non-insulated areas of the pressure washer.

**AVERTISSEMENT:** Risque de blessures. Les surfaces chaudes peuvent causer des brûlures. Utiliser uniquement les zones de prise désignées du pistolet pulvérisateur et de la lance. Ne pas placer les mains ou les pieds sur des endroits non isolés de la laveuse à pression.

12. Transport/Repair with fuel tank EMPTY or with fuel shut-off valve OFF.



**CAUTION:** Hot discharge fluid. Do not touch or direct discharge stream at persons.

**ATTENTION:** Liquide de décharge chaud. Ne pas toucher ou décharger directement le jet vers des personnes

**WARNING:** This machine produces hot water and must have insulated components attached to protect the operator.

**AVERTISSEMENT:** Cette machine produit de l'eau chaude et doit comporter des composants isolés attachés pour protéger l'opérateur.

13. To reduce the risk of injury, close supervision is necessary when a machine is used near children. Do not allow children to operate the pressure washer. **This machine must be attended during operation.**

## IMPORTANT SAFETY INFORMATION



**WARNING:** Grip cleaning wand securely with both hands before starting. Failure to do this could result in injury from a whipping wand.

**AVERTISSEMENT:** Agripper la lance de nettoyage avec les deux mains avant de commencer. Le non-respect de cette consigne pourrait mener à des blessures

causées par le mouvement violent de la lance.

14. Never make adjustments on machine while in operation.
15. Be certain all quick coupler fittings are secured before using pressure washer.



**WARNING:** High pressure developed by these machines will cause personal injury or equipment damage. Keep clear of nozzle. Use caution when operating. Do not direct discharge stream at people, or severe injury or death will result.

**AVERTISSEMENT :** La haute pression générée par ces machines causera des lésions corporelles ou des dommages à l'équipement. Se tenir à l'écart de la buse. Faire preuve de prudence lors de l'utilisation. Ne pas décharger directement le jet vers des gens, cela pourrait causer des blessures graves voire la mort.



**WARNING:** Protect machine from freezing.

**AVERTISSEMENT :** Protéger la machine contre le gel.

16. To keep machine in best operating conditions, it is important you protect machine from freezing. Failure to protect

machine from freezing could cause malfunction of the machine and result in death, serious bodily injury, and/or property damage. Follow storage instructions specified in this manual.

17. Inlet water must be clean fresh water and no hotter than 90°F.



**WARNING:** Risk of asphyxiation. Use this product only in a well ventilated area.

**AVERTISSEMENT :** Risque d'asphyxie. Utiliser ce produit uniquement dans un endroit bien ventilé.

18. Avoid installing machines in small areas or near exhaust fans. Adequate oxygen is needed for combustion or dangerous carbon monoxide will result.
19. Manufacturer will not be liable for any changes made to our standard machines or any components not purchased from us.
20. The best insurance against an accident is precaution and knowledge of the machine.



**WARNING:** Be extremely careful when using a ladder, scaffolding or any other relatively unstable location. The cleaning area should have adequate slopes and drainage to reduce the possibility of a fall due to slippery surfaces.

**AVERTISSEMENT :** Faire preuve d'une extrême prudence au moment d'utiliser une échelle, des échafaudages ou toute autre surface relativement instable. La zone de nettoyage doit avoir une pente et un drainage adéquats pour réduire la possibilité d'une chute due à une surface glissante.

21. Do not allow acids, caustic or abrasive fluids to pass through the pump.
22. Never run pump dry or leave spray gun closed longer than 1-2 minutes.
23. Machines with shut-off spray gun should not be operated with the spray gun in the off position for extensive periods of time as this may cause damage to the pump.
24. Protect discharge hose from vehicle traffic and sharp objects. Inspect condition of high pressure hose before using or bodily injury may result.
25. Before disconnecting discharge hose from water outlet, turn burner off and open spray gun to allow water to cool below 100° before stopping the machine. Then open the spray gun to relieve pressure. Failure to properly cool down or maintain the heating coil may result in a steam explosion.
26. Do not overreach or stand on unstable support. Keep good footing and balance at all times.
27. Do not operate this machine when fatigued or under the influence of alcohol, prescription medications, or drugs.
28. In oil burning models, use only kerosene, No. 1 home heating fuel, or diesel. If diesel is used, add a soot remover to every tankful.



**Follow the maintenance instructions specified in the manual.**

# COMPONENT IDENTIFICATION

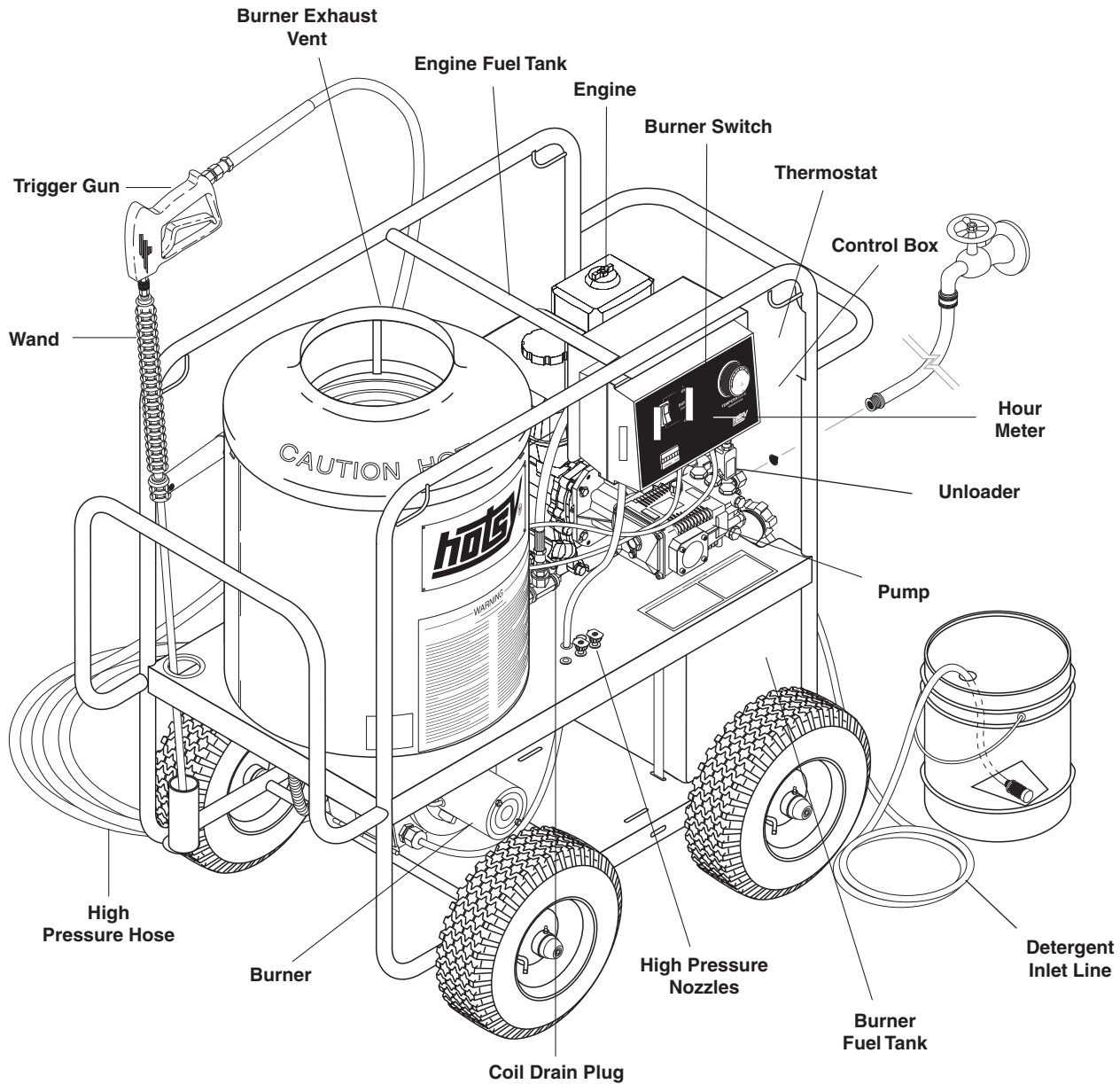

**Pump** — Delivers a specific gpm to the high pressure nozzle which develops pressure.

**Spray Gun** — Controls the application of water and detergent onto cleaning surface with trigger device. Includes safety latch.

**Wand** — Must be connected to the spray gun.

**High Pressure Hose** — Connect one end to water pump high pressure discharge nipple and the other end to spray gun.

**Unloader Valve** — Safety device which, when the spray gun closes, prevents over pressurization.



# ASSEMBLY INSTRUCTIONS

## Unpacking

Unpack carefully. Wear safety glasses or goggles while unpacking, assembling, or operating pressure washer. If there are missing components or hidden damage, immediately contact carrier concerning discrepancies.

1. Cut strapping band from pressure washer and pallet.
2. Remove pressure washer from pallet.

## Parts Included

- Pressure Washer
- Pressure Hose
- Wand
- Operating Instructions and Parts Manual
- Gasoline Engine Manual
- Parts Bag Containing:
  - Pressure Nozzles (3 Ea.)
  - Quick Disconnects (2 Ea.)
  - Quick Disconnect Plug
  - Trigger Gun

## Tools Required

- 8" Adjustable Wrench
- Teflon Tape
- Flat Blade Screwdriver

## Pressure Hose, Trigger Gun and Wand

1. When assembling, use teflon tape on all threaded plumbing connections to prevent leakage.
2. Install the pressure hose on the pressure washer as shown in **Figure 1**.
3. Assemble wand components as shown in **Figure 2**.

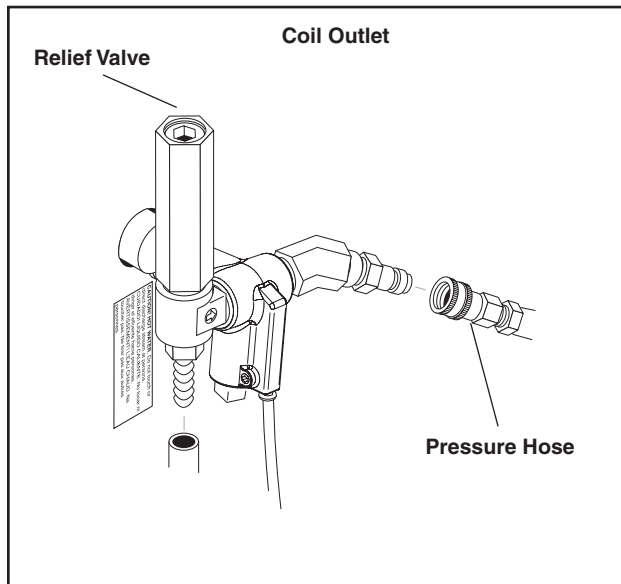

**Figure 1 - Pressure Hose Installation**

**NOTE:** The pressure nozzle is not to be installed at

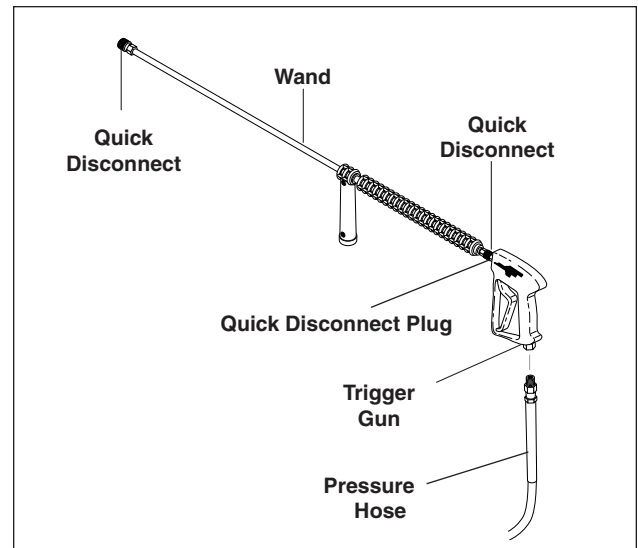

**Figure 2 - Wand Component Installation**

this time.

4. Make sure all plumbing connections are tight.

# INSTALLATION INSTRUCTIONS

## Getting Started

**IMPORTANT:** Proper initial installation of equipment will assure more satisfactory performance, longer service life, and lower maintenance cost.

**IMPORTANT:** The use of a backflow preventer on the water supply hose is recommended and may be required by local code.

The pressure washer should be run on a level surface and in a protected area where it is not readily influenced by outside forces such as strong winds, freezing temperatures, rain, etc. The pressure washer should be located to assure easy access for filling of fluids, adjustments and maintenance. Normal precautions should be taken by the operator to prevent moisture from reaching the pressure washer. It is recommended that a partition be made between the wash area and the pressure washer to prevent direct spray from the wand from coming in contact with the pressure washer. Moisture reaching the equipment will reduce the pressure washer's service life. All installations must comply with the local codes covering such installations.

## Venting

**DANGER: DO NOT run machine indoors or in an enclosed area, as exhaust fumes may be hazardous to your health.**

**DANGER: DO NOT operate machine in areas where flammable vapors (gasoline, solvents, etc.) may be present, as this machine may ignite the vapors.**

**CAUTION: All venting must be in accordance with applicable federal and state laws, and local ordinances. Consult local heating contractors.**

If the pressure washer is to be used in an enclosed area, a flue must be installed to vent burner and engine exhaust to the outside atmosphere. Be sure the flue is the same size as the burner exhaust vent on the pressure washer. See **Figure 1** for location. Poor draft will cause the pressure washer to soot and not operate properly. When selecting the location for installation, beware of poorly ventilated locations or areas where exhaust fans

may cause an insufficient supply of oxygen. Proper combustion can only be obtained when there is a sufficient supply of oxygen available for the amount of fuel being burned. If it is necessary to install the machine in a poorly ventilated area, outside fresh air may have to be piped to the burner and a fan installed to bring sufficient air into the machine. Locate the pressure washer so that the flue will be as straight as possible and protrude through the roof at a proper height and location to provide adequate draft. This oil fired pressure washer must have a draft regulator installed in the flue (available from most heating contractors). A draft regulator will permit proper upward flow of exhaust flue gases.

In addition, the pressure washer should never be operated in an enclosed area where high ambient temperatures exist. High ambient temperatures (above 100° F) can cause engine oil failure and will greatly reduce the engine's performance.

## Gasoline Engine

The gasoline engine is preset for operation at altitudes below 1000 feet above sea level. If operated at higher altitudes, it may be necessary to install a high altitude main jet in the carburetor. Contact an authorized engine sales and service center for details.

## Pre-Operation Check

- Pump Oil (SAE 30W non-detergent oil)
- Cold Water Supply (3.5 gpm • 5/8" • 20 psi)
- Hose, wand, nozzles (nozzle size per serial plate)
- Water filter (intact, nonrestrictive)
- Engine fuel (unleaded 86 or higher)
- Engine oil (SAE 10W40)
- Burner fuel (No. 1 or No.2 home heating fuel or diesel)

# INSTALLATION INSTRUCTIONS

## Wayne Oil Burner

### Burner Air Adjustment:

The oil burner on this machine is preset for operation at altitudes below 500 feet. If operated at higher altitudes, it may be necessary to adjust the air band for a #1 or #2 smoke spot on the Bacharach scale.

To adjust, start machine and turn burner ON. Loosen two locking screws found on the air band and close air band until black smoke appears from burner exhaust vent. Note air band position. Next, slowly open the air band until white smoke just starts to appear. Turn air band halfway back to the previously noted position. Tighten locking screws.

- For higher altitudes, the air band opening may need to be increased; for lower altitude, the air band may need to be decreased.
- For higher humidity, the air band opening may need to be increased; for lower relative humidity, the air band may need to be decreased.
- For higher ambient temperatures the air band opening may need to be increased; for lower ambient temperatures, the air band opening may need to be decreased.
- Adjust to your operating location's environment as needed for best smoke spot and performance compliant with local, state, and federal regulations.

### Fuel Pressure Adjustment:

To adjust fuel pressure, First install a pressure gage into the port just after the pump fuel exit. Turn the adjusting screw (located at the regulator port) clockwise to increase, and counterclockwise to decrease.

Do not exceed 205 psi or lower the pressure below 130 PSI, when checked at the post-pump pressure port.

The fuel pressure may need to be adjusted due to altitude. For every 500 ft altitude above sea level, the boiling point of water goes down 1 °F. At high altitude environments, this boiling point change may require the heat input to be lowered so the water input does not turn to steam earlier than at the factory settings and activate the pressure sensors and pressure relief equipment when the unit is operated and much higher altitudes from factory settings or local dealer site settings. Check with your dealer before making local site fuel pressure adjustments.

Also, as ambient temperature changes seasonally, the fuel temperature in the feed tank and air temperature inlet can impact fuel flow. In more extreme temperatures, this local-site adjustment may also require different fuel nozzles for fuel inlet temperatures that are at seasonal extremes (higher or lower) in locations where the temperature changes are beyond moderate temperatures of between 40°F and 90°F. Colder temperatures will make for a thicker flow and less fine a fuel spray while hotter temperatures will make for a thinner flow a more fine spray with the same nozzle. Consider alternate nozzle configurations from the baseline factory-supplied nozzle for operating in such temperature extremes if performance is not meeting needs with air band and fuel pressure settings alone.

**NOTE:** When changing fuel pump, a by-pass plug must be installed in return line port or fuel pump will not prime.

# OPERATION INSTRUCTIONS

## Before Starting

1. Read all manuals provided with this pressure washer. Become familiar with location and function of all operating and safety controls.

**WARNING: Check hoses, fittings, wand, trigger gun and fuel connections daily for signs of wear, cracks and looseness, and replace as required.**

2. Connect water supply hose to the garden hose connector located on pump. The water faucet and supply hose must be capable of providing a minimum of 3.5 gallons per minute (GPM).
3. Fill oil burner fuel tank. Use kerosene, #1 grade home heating oil, #1 or #2 diesel fuel. **DO NOT USE GASOLINE, CRANKCASE OIL DRAININGS, OR WASTE OIL.**

**WARNING: DO NOT fill engine fuel tank while engine is running or hot. Let engine cool before refueling or spontaneous fire may result. Fuel spillage or vapors could ignite if engine is hot.**

4. Fill the engine fuel tank. Do not overfill, fill to the bottom of filler neck only. Use lead free gasoline minimum 86 octane. **DO NOT** use gasoline containing more than 15% MTBE, 5% methanol or 10% ethanol. Refer to the provided gasoline engine manual for additional details.
5. Check pump and engine oil levels.
6. If detergents are to be used, only use detergents intended for pressure washers. Follow instructions on the detergent container.

**IMPORTANT: Before installing pressure nozzle on initial start-up, turn on the water supply and allow water to run from the end of the wand until clear to prevent the pressure nozzle from clogging.**

**IMPORTANT: If the pressure washer has not been used for an extended period of time, remove the pressure nozzle from the end of the wand and turn on water supply. Allow water to run from the end of the wand until clear.**

7. Install the proper pressure nozzle for your cleaning needs on the end of wand, refer to **Figure 4**.

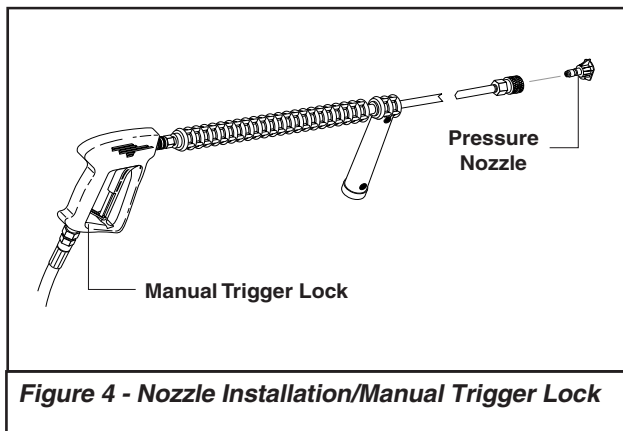

**Figure 4 - Nozzle Installation/Manual Trigger Lock**

**IMPORTANT: The trigger gun provided with this pressure washer is equipped with a manual trigger lock to prevent accidental operation of the trigger gun. (Refer to Figure 4) The manual trigger lock should be used whenever the trigger gun is not in use.**

## To Start

**DANGER: DO NOT point wand or trigger gun at yourself or at any person. Bodily injury may result from water under high pressure.**

**WARNING: Wear eye, ear, hand, foot and skin protection at all times while operating pressure washer.**

**IMPORTANT: The water must be turned on before starting. Running the pump dry will cause damage and void warranty.**

**IMPORTANT: DO NOT allow the machine to run with trigger of the trigger gun released for more than 10 minutes at any one time or damage to pump may occur.**

1. Turn ON water supply.
2. Hold wand firmly, release trigger of trigger gun.
3. Place engine ON/OFF switch in the ON position.
4. Open fuel shutoff valve (if so equipped). Move choke lever to FULL CHOKE position, (choke may not be needed on warm engine). Move throttle lever to HALF THROTTLE position.
5. Pull the rope starter slowly until resistance is felt, then pull briskly. Do not allow the rope starter to snap back against the engine. Return it gently to prevent damage to the starter.
6. When the engine starts, move choke lever until engine runs smoothly. When engine warms, move choke lever to NO CHOKE position. Move throttle lever to FULL THROTTLE position.

**IMPORTANT: To allow for proper burner operation, the throttle control must be kept in the full throttle position during operation.**

**NOTE: If engine fails to start, refer to Troubleshooting Guide in this manual.**

7. Squeeze trigger of trigger gun and allow air to purge from system.
8. If HOT water is desired, adjust the thermostat to the proper temperature and turn burner switch ON. The burner will light immediately with a small puff of smoke. You may need to initially adjust your burner for peak performance. See **Oil Burner** section under **Installation**. If smoke continues, contact **Customer Service at 1-303-792-5200**. When the trigger of the trigger gun is released or when the thermostat temperature setting is reached, the burner will automatically turn off.

# OPERATION INSTRUCTIONS

## To Clean

**DANGER: DO NOT place hands or fingers in front of high pressure spray. Bodily injury may result.**

The detergent injector valve operates by reducing the volume of water, thus a vacuum is achieved and detergent is drawn into the system. **DO NOT** reduce the water inlet flow so the pump cavitates due to water starvation. Operating a pump with insufficient water will damage the pump seals.

1. Insert detergent inlet line into container of mixed detergent.
2. Completely open detergent control knob located on the side of the detergent injector valve. Refer to **Figure 5**.

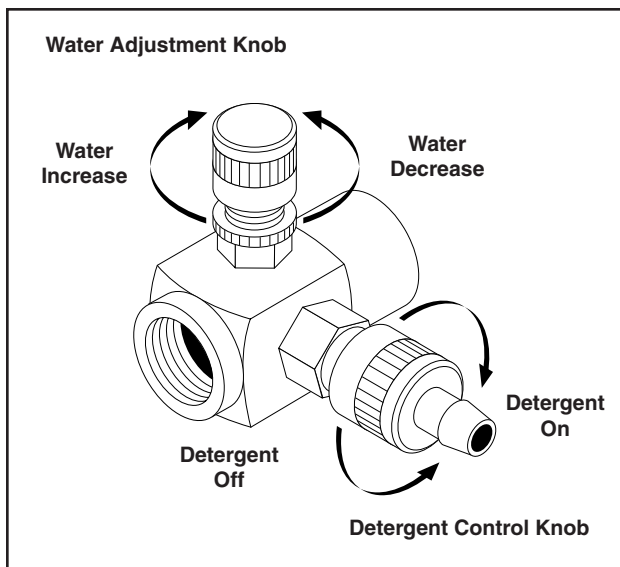

**Figure 5 - Detergent Injector Valve**

3. Start the detergent suction by rotating the water adjustment knob of the detergent injector valve. Refer to **Figure 6**. Turning the knob counterclockwise will pull detergent into the system. The flow may be observed through the clear detergent line. Secure the knob position with the knurled nut.
4. The side detergent control knob can now be adjusted to meter the desired amount of detergent.
5. Wash from the bottom to the top, using side to side motions. This washes away heavy dirt and allows the detergent to soak as you work toward the top.
6. Do not wash at a 90° angle to the work (straight at it). This will allow water to splash back at you and reduces your cleaning power. Wash at a 30° to 60° angle to the work. This will allow the water to splash away from you and the water will wash the dirt away faster and easier.
7. Use the width of the spray pattern to wash in a wide path. Overlap spray paths for complete coverage washing from side to side, using slow, steady motions.

8. The nozzle should be 12" to 24" from work, closer for tough areas. Be careful on painted or delicate surfaces, the pressure may damage surface if nozzle is too close.
9. Small parts should be washed in a basket so the pressure does not push them away. Larger, lightweight parts should be clamped down so the pressure does not push them away.
10. Turn the side detergent control knob clockwise (CW) for detergent decrease. Wait for detergent to clear. Always rinse with cold water after using detergent. Rinse from the top to the bottom to prevent detergent from dripping onto a rinsed area. For the best results, contact your Hotsy dealer to help you select the best detergent for your application.

## To Stop

1. If detergents were used, draw clear water through the detergent inlet line to purge detergent. Failure to do so may clog detergent injector valve.
2. If burner was used, turn OFF burner switch and allow pump to run cold water through coil for several minutes.
3. Move throttle lever to idle position.
4. Turn engine ON/OFF switch to the OFF position.
5. Close fuel shutoff valve (if so equipped).
6. Turn water supply OFF.
7. Squeeze trigger of trigger gun to relieve system pressure.

## STORAGE

**DANGER: DO NOT store flammable liquids (gasoline, diesel fuel, solvents, etc.) near pressure washer, or in non-ventilated areas.**

Protect from freezing by storing in a heated area, or by flushing the system with antifreeze (use an automotive engine antifreeze or windshield washer solvent to antifreeze). To flush the system with antifreeze, the following steps are to be followed:

1. Connect the water supply hose to the garden hose connector located on the pump. Turn on water supply.
2. Place the detergent inlet line into a container of antifreeze.
3. Hold wand firmly, release trigger of trigger gun.
4. Start engine. Place throttle lever in Full Throttle position.
5. Squeeze trigger of trigger gun and allow water to flow from the end of the wand. Watch for antifreeze to be drawn through the detergent inlet line. Allow the antifreeze to be drawn into the system for 5 to 10 seconds.
6. Release trigger of the trigger gun and stop engine.
7. Turn off water supply and disconnect water supply hose from the pump.

## OPERATION INSTRUCTIONS

- Attach a short length of hose (approximately 3 feet long) to the garden hose connector located on the pump. Install a funnel in the other end of the hose as shown in **Figure 6**.

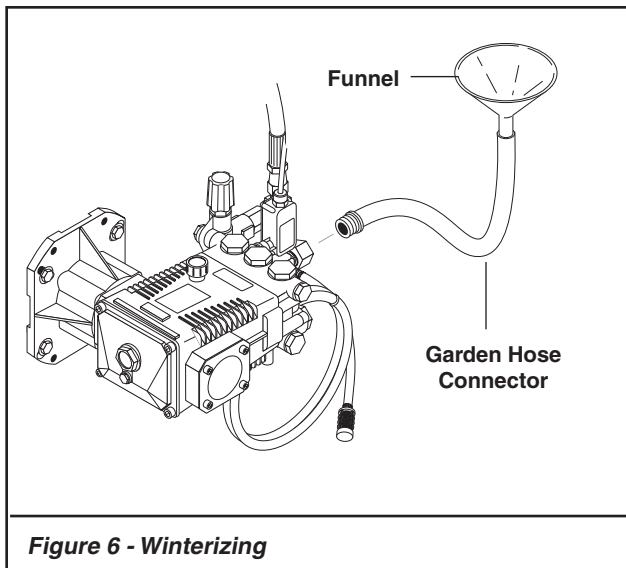

**Figure 6 - Winterizing**

- Hold wand firmly, release the trigger of the trigger gun.
- Start engine. Place throttle lever in the idle position.
- Squeeze trigger on trigger gun.
- Slowly pour antifreeze into the funnel. Continue to add antifreeze until antifreeze flows from the end of the wand.
- Squeeze and release the trigger of the trigger gun several times to antifreeze the unloader system.
- Release the trigger of the trigger gun. Stop engine.
- Squeeze the trigger of the trigger gun to relieve system pressure.

For added protection, after anti-freezing, disconnect the pressure hose from the machine and remove the coil drain plug. After coil has drained, replace pressure hose and coil drain plug. If the pressure washer is not to be used for an extended length of time, it is recommended that the system be flushed with antifreeze for rust protection. Refer to the **Gasoline Engine Manual** for engine storage information.

# MAINTENANCE

**WARNING:** *Unauthorized machine modification or use of non-approved replacement parts may cause personal injury and/or property damage and will void the manufacturer warranty.*

## Pump

**Lubrication:** To lubricate pump, use 30W non-detergent oil for pump crankcase. Crankcase must be filled to center of red dot on oil gauge found on the end of the pump, refer to **Figure 7**. During the break-in-period, make sure the oil is changed after the first 40 hours of operation. After that, replace oil every 3 months or 500 hours of operation, whichever comes first.

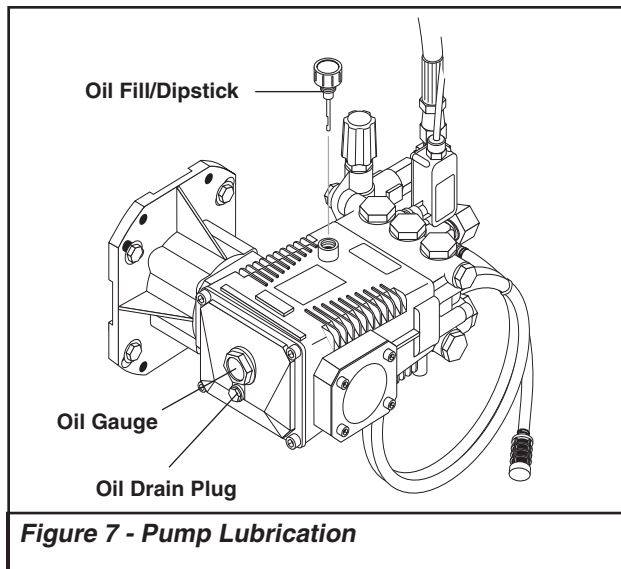

## Proper Pump Care:

- **DO NOT** pump acids.
- **DO NOT** allow pump to run dry.
- Winterize if storing in freezing temperatures, refer to **Storage** for details.
- Use a water softener on the water system if known to be high in mineral content.
- Use only high quality detergents and follow manufacturer's mix recommendations.
- Flush the system with clear water immediately after using detergent solutions.
- Clean filter screen on detergent inlet line periodically.
- Flush the pressure washer system with antifreeze if storing for an extended period of time, refer to **Storage** for details.

## Gasoline Engine

Refer to the provided **Gasoline Engine Manual** for recommended maintenance.

## Relief Valve

**WARNING:** *The relief valve on this pressure washer has been factory set and sealed and is a field non-adjustable part. Tampering with the factory setting may cause personal injury and/or property damage, and will void the manufacturer warranty. For replacement parts refer to Coil Outlet Assembly.*

If pressure from pump or thermal expansion should exceed safe limits, the relief valve will open, allowing high pressure to be discharged through hose to ground.

**Caution:** *Inspect relief valve annually for any obstruction.*

## Unloader Valve

**WARNING:** *The unloader valve on this pressure washer has been factory set and sealed and is a field non-adjustable part. Tampering with the factory setting may cause personal injury and/or property damage, and will void the manufacturer warranty.*

## Burner Fuel Filter

Drain any water which has accumulated in fuel filter and clean or replace filter element as needed.

## Heating Coil

**Coil Descaling:** In hard water areas, scale buildup within the heating coil will occur. Scale deposits will decrease the water temperature rise and may eventually clog the heating coil. Contact your local service center when descaling is needed.

**Coil Desooting:** Poor grades of fuel oil or inadequate combustion air will cause heavy soot buildup on the outside surface of the heating coil. These deposits will insulate the coil. This will restrict the air flow through the coil, further aggravating the soot buildup. Contact your local service center when desooting is needed.

## Hour Meter

This hour meter will monitor the total hours of operation of the pressure washer to signal when routine maintenance is required.

## TROUBLESHOOTING

SYMPTOM	POSSIBLE CAUSES	CORRECTIVE ACTION
<b>GAS ENGINE WILL NOT RUN.</b>	Out of gas	Replenish supply. Use only recommended fuels. Refer to <b>Before Starting</b> under <b>Operation</b> .
	Fuel valve closed (if so equipped)	Open valve.
	Loose spark plug wire	Reconnect.
	Choke or throttle set incorrectly	Refer to <b>To Start</b> under <b>Operation</b> .
	Engine ON/OFF switch in OFF position	Place engine ON/OFF switch in ON position.
	Low engine oil level.	Replenish supply. Engine will not start or run if oil is low (on engines equipped with low oil protection).
	<b>Refer to provided gasoline engine manual for additional troubleshooting</b>	
<b>PRESSURE WASHER RUNS BUT WON'T SPRAY.</b>	Trigger of trigger gun released	Squeeze trigger.
	Water supply not turned on	Open water supply valve.
	Clogged pressure nozzle	Clean pressure nozzle opening.
	<b>If water spray doesn't show with in 10-15 seconds discontinue running the machine and troubleshoot as damage to the pump will occur if allowed to run</b>	
<b>LOW SPRAY PRESSURE AT PRESSURE NOZZLE.</b>	Inadequate water supply.	Fully open faucet. Check for kinked or damaged hose. Use 3/4 inch minimum hose. Check for debris clogging inlet screen.
	Partially clogged or damaged pressure nozzle	Clean or replace.
	Air being drawn through detergent inlet line	Refill detergent container. Ensure that pick-up screen is fully immersed.
	Detergent injector valve not set correctly	Refer to <b>To Clean</b> for settings.
<b>UNEVEN SPRAY PATTERN.</b>	Partially clogged or damaged pressure nozzle.	Clean or replace.
<b>PRESSURE WASHER WILL NOT PRODUCE HOT WATER.</b>	Burner switch in OFF position.	Place switch in ON position.
	Inadequate fuel supply	Refill fuel tank. Use only recommended fuels. Refer to <b>Before Starting</b> under <b>Operation</b> .
	Inadequate water supply	Fully open faucet. Check for kinked or damaged hose. Use 3/4 inch minimum hose. Check for debris clogging inlet screen.
	Trigger of trigger gun released	Squeeze trigger. Water must be spraying for burner to light



## TROUBLESHOOTING

SYMPTOM	POSSIBLE CAUSES	CORRECTIVE ACTION
<b>PRESSURE WASHER WILL NOT PRODUCE HOT WATER</b> ...continued	Thermostat set too low.	Adjust thermostat to desired temperature.
	Blown fuse	Replace. Fuse is located in Control Box.
	Engine is running too slow	Move throttle lever to full throttle position.
<b>POOR OR NO DETERGENT FLOW.</b>	Inadequate detergent supply.	Refill detergent container. Ensure that pick-up screen is fully immersed. Open detergent valve.
	Detergent screen or hose clogged	Clean. Always start with a clean detergent container.
	Detergent injector valve not set correctly	Refer to <b>To Clean</b> for settings.
	Clogged detergent injector check valve	Clean check valve at detergent injector inlet.
<b>POOR CLEANING.</b>	Improper detergent concentration or mixing.	Mix detergent per manufacturer's instructions. Ensure that powdered detergents are fully dissolved.
	Wrong detergent for the application	Select appropriate detergent
	Rinsing with hot water	A final rinse with cold water will reduce water spotting

### IMPORTANT

If the pressure washer demonstrates other symptoms or the corrective actions listed do not correct the problem, contact the local authorized Hotsy Service Center. The Hotsy Service Center can be identified by visiting [www.hotsy.com](http://www.hotsy.com)

**When ordering from your dealer, please provide the following:**

**Model Number: 871SS.**

**Machine Serial Number:** \_\_\_\_\_

**Component Part Number:** \_\_\_\_\_

**Description:** \_\_\_\_\_

# EXPLODED VIEW - LEFT SIDE

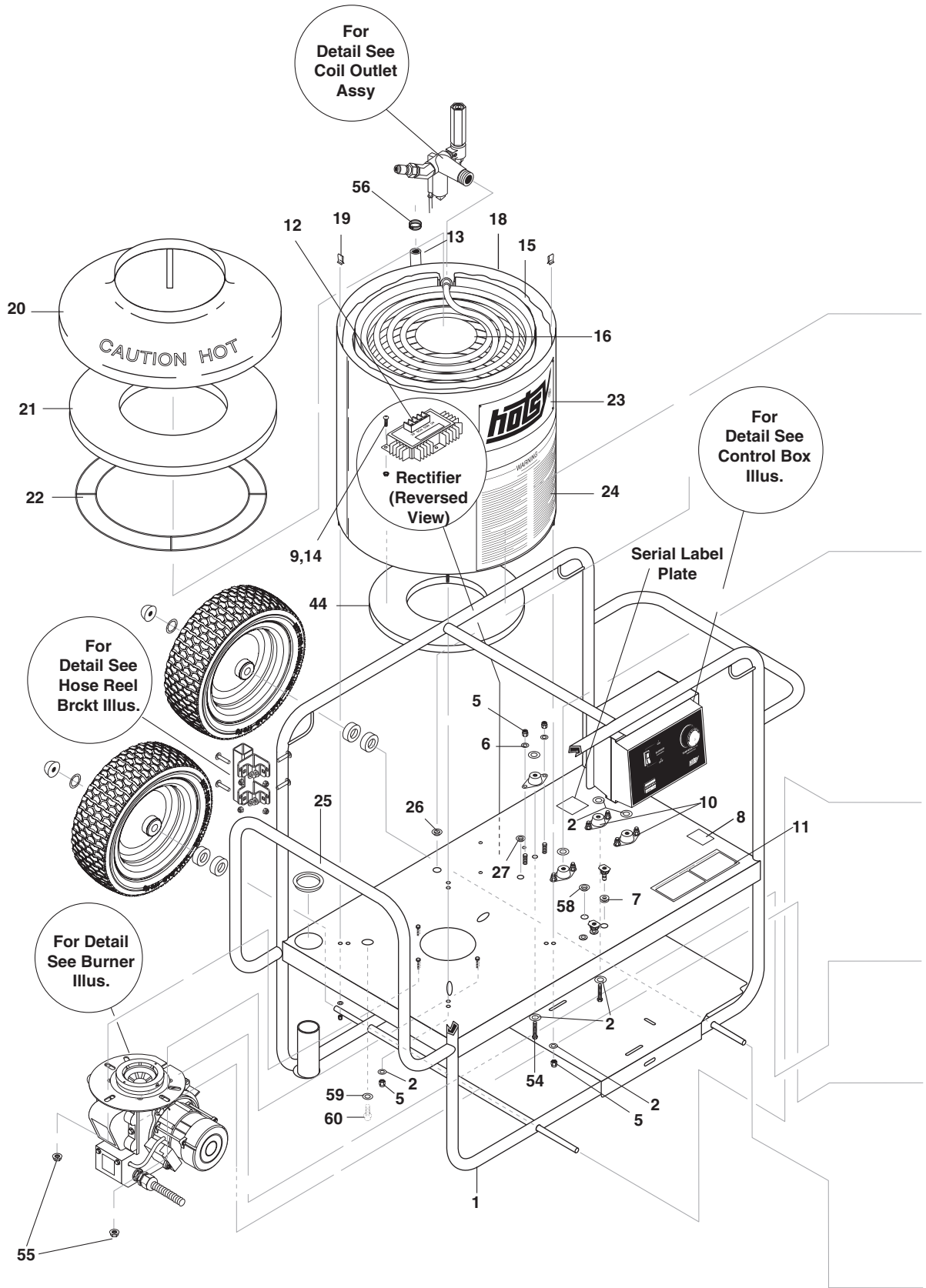

# EXPLODED VIEW - RIGHT SIDE

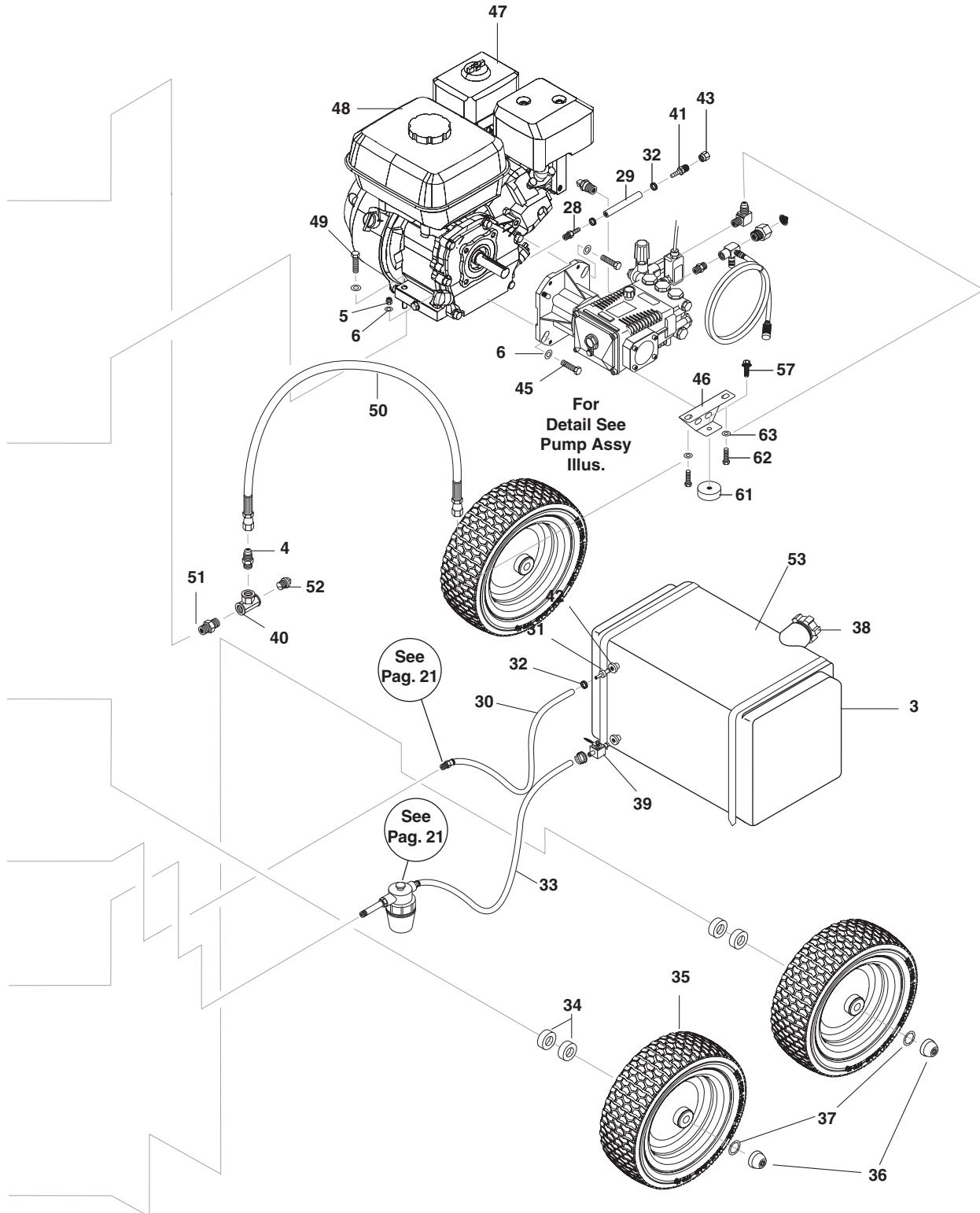

## EXPLODED VIEW - PARTS LIST

ITEM	PART NO.	DESCRIPTION	QTY	ITEM	PART NO.	DESCRIPTION	QTY
1	8.911-657.0	Chassis, Welded Assy	1	38	9.803-535.0	Cap, w/Fuel Gauge	1
2	9.198-014.0	Washer, 5/16" x 1-1/4", Fender, SAE	4	39	9.802-177.0	Valve 1/4" Shut-off	1
3	9.802-081.0	Tank, Fuel, 6-Gallon	1	40	8.757-944.0	Tee steel 3/8 NPTF (F)	1
4	8.757-655.0	Adapter steel 1/2 JIC (M) x 3/8 NPTF (M)	1	41	8.757-201.0	Hose Barb, 1/4" Barb x 1/8" M-NPTF	1
5	9.802-776.0	Nut, 5/16", SMAEC, NC	17	42	9.802-053.0	Bushing, Rubber, Nitrile	2
6	8.718-980.0	Washer, 5/16", Flat, SAE	14	43	8.706-321.0	Cap, Pipe, 1/8"NPT Brass	1
7	9.802-064.0	Grommet, Rubber, Nozzle Holder	3	44	9.802-903.0	Insulation, Bottom 16 OD x 4.5 Fiberglass	1
8	8.901-172.0	Label, Detergent Metering	1	45	9.802-707.0	Bolt, 5/16" - 24 x 3/4" Nf HH	4
9	9.802-695.0	Nut, 10/32" Keps	4	46	8.917-977.0	Pump Support LG Fab Black Wrinkle	1
10	9.803-308.0	Mount Rubber Vibration, 5/16", 70 Duro	4	47	9.800-006.0	Label, Hot/Caliente w/Arrows Warning	1
11	8.901-206.0	Label, Instructions	1	48	8.758-904.0	Gasoline engine GX200 Charging System	1
12	9.802-531.0	Regulator, Voltage, 15 Volt	1	49	8.718-772.0	Screw, 5/16" x 1-1/2" Whiz	2
13	8.911-761.0	Hose, 3/8" Push-on	30"	50	8.918-424.0	Hose, 3/8" x 25", 2 Wire, Pressure Loop	1
14	9.802-771.0	Screw, 10/32" x 3/4" Bh Soc Cs	4	51	9.802-778.0	Nut, 5/16" Whiz Loc Flange	1
15	9.802-908.0	Insulation, Blanket 18" x 52"	1	52	8.706-241.0	Plug, 3/8", Sq. Head, Galv.	1
16	8.919-135.0	Coil, 16"	1	53	9.802-512.0	Cable Tie 48"	2
17	9.802-814.0	Washer, 3/8", Lock Split Ring	4	54	9.802-832.0	Bolt, 5/16" x 2-3/4" Whiz Loc (781SS, 871SS)	2
18	8.911-802.0	Coil, Tank SS, Weldment	1	55	9.802-786.0	Nut Whizlock Flange 5/16	4
19	9.802-825.0	Clip, Retaining, U-Type	4	56	8.709-117.0	Clamp Hose	1
20	8.719-913.0	Top Hat, Weld Assy, 16" Hotsy Coil	1	57	9.803-277.0	Screw, 5/16" x 1/2", Whiz LOC Flange	1
21	9.802-904.0	Insulation, Cerafelt, 16 OD x 8.3 ID	1	58	9.802-103.0	Bushing, Snap, 5/8"	1
22	9.803-108.0	Ring, Insulation Retainer, 16" Top Hat	1		8.901-133.0	▲Label, Warning, Carbon Monoxide	1
23	8.901-214.0	Label, Plate Aluminum	2		8.901-134.0	▲Label, Fuel Type	1
24	8.900-285.0	Label, Warnings	1		8.901-135.0	▲Label, Caution Winterize	1
25	9.803-544.0	Grommet, 2-1/8" x 2-7/8" x 7/16" Rubber	1		8.901-136.0	▲Label, Use Hotsy Detergent	1
26	9.802-104.0	Bushing, 1" Snap	2		8.901-171.0	▲Label, Troubleshooting	1
27	8.706-731.0	Bushing, Snap, 3/4"	1		8.718-207.0	▲Insulation Pancake, 18"	1
28	8.757-499.0	Hose Barb 10-1.25 x 1/4" pipe	1		9.802-958.0	▲Key, 0.185 Sqr x 1.75"	1
29	9.802-254.0	Hose, 1/4" x 1.67', Push-On, Fuel Line	8"		8.901-119.0	▲Tag, Oil Burner	1
30	9.802-254.0	Hose, 1/4" x 1.67', Push-On, Fuel Line	12"			▲Tab, Gas Engine	1
31	9.802-141.0	Hose Barb, 1/4" Barb x 3/8 Barb Double 3	1		8.901-117.0	▲Warning, Unloader	1
32	6.390-126.0	Clamp, Hose, UNI .46-.54 ST	4		9.800-049.0	▲Label, Cleaning Solution	1
33	9.802-254.0	Hose, 1/4" x 1.67', Push-On, Fuel Line	10"	59	9.802-819.0	Washer, 7/16" x 2 1/2", Zinc, PG Foot	3
34	8.751-374.0	Spacer 5/8 X 1,25 Black	8	60	9.802-710.0	Screw 5/16" x 1"NC	3
35	8.758-460.0	Wheel 12 In. Rim Steel	4	61	9.183-409.0	Rubber Dampener 5/16"- 18Female 2001	1
36	9.182-506.0	Cap Black Plastic 5/8"	4	62	9.802-741.0	Bolt, 8mm x 16mm Hex Head	2
37	8.718-870.0	Nut, .61 ID, Push, Flat	4	63	8.718-980.0	Washer, 5/16" Flat, SAE (780452)	2

▲Not Shown

## BURNER ASSEMBLY

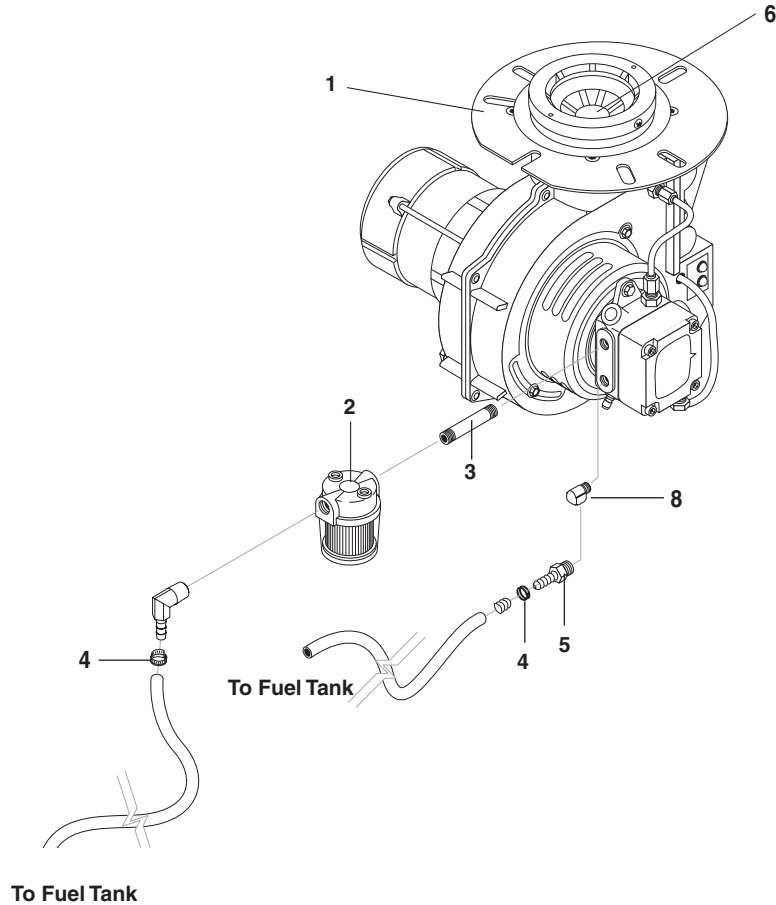

## BURNER ASSEMBLY PARTS LIST

ITEM	PART NO.	DESCRIPTION	QTY
1	8.756-655.0	Burner, MSR 12V 1T 12V S DC	1
2	8.757-652.0	Filter Fuel Hotsy 1/4" female	1
3	8.757-366.0	Nipple, 1/4" X 3", W/SLNT	1
4	6.390-126.0	Clamp, Hose, .46-.54 St	2
5	8.757-199.0	Hose Barb, 1/4" Barb x 1/4" M-NPTF, BRASS	
6	8.754-916.0	▲Fuel Nozzle, 1.50 x 90BZ	1
7	8.757-205.0	Hose Barb, 1/4" Barb x 1/4" M-NPTF, 90°	1
8	8.757-198.0	Elbow, 1/4" street, Brass	1

▲Not Shown

## CONTROL BOX ASSEMBLY

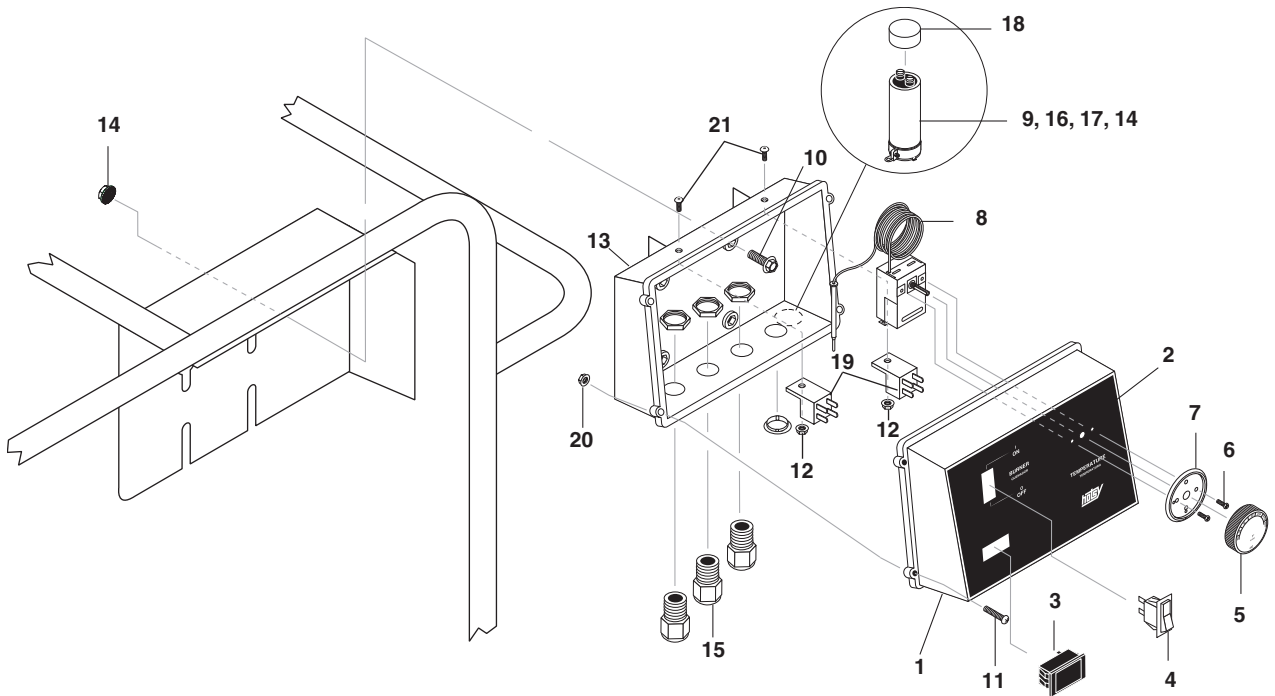

### CONTROL BOX PARTS LIST

ITEM	PART NO.	DESCRIPTION	QTY	ITEM	PART NO.	DESCRIPTION	QTY
1	8.719-947.0	Box, Plastic, Front, 2 Square Holes	1	19	9.802-470.0	Relay, 12V	2
2	8.900-924.0	Label, 1200SSG Control Box	1	20	9.803-250.0	Nut, (Electrical Box)	4
3	9.802-283.0	Hour Meter, 24-240 Vac 50/60 Hz	1	21	9.802-759.0	Screw, 10/32" x 1/2" BHSOC Blk	2
4	8.716-036.0	Switch, Rocker, 15A/12V Lt	1	▲Not Shown			
5	8.750-097.0	Knob, Thermostat 120C/248F	1				
6	8.718-779.0	Screw, 4mm x 6mm Pan Head	2				
7	8.712-190.0	Bezel, Plastic, Thermostat	1				
8	8.750-095.0	Thermostat, 120C/240F, 2 Meter Capillary	1				
9	9.802-528.0	Capacitor	1				
10	9.802-700.0	Bolt, 1/4-20 x 3/4", Nc Hh	4				
11	9.803-249.0	Screw, M4 x 10	4				
12	9.804-567.0	Nut, 10/32', ESNA	2				
13	9.802-480.0	Back Box	1				
14	9.802-775.0	Nut, 1/4" Flange, ZN	5				
15	8.716-545.0	Strain Relief, .27-.48 .80 Hole	3				
	8.716-206.0	▲Fuse, ATC 30 Amp	1				
	8.716-223.0	▲Holder, Fuse	1				
	8.706-745.0	▲Plug, Plastic 0.812	1				
16	9.802-206.0	Clamp, Wire/Tube, 1.312 Dia	1				
17	8.718-582.0	Bolt, 1/4-20 x 1/2", Nc Hh	1				
18	9.803-048.0	Cap, Capacitor, 1.37 x 1.5 x .06 BLK, w/o Hole	1				

## COIL OUTLET ASSEMBLY AND PARTS LIST

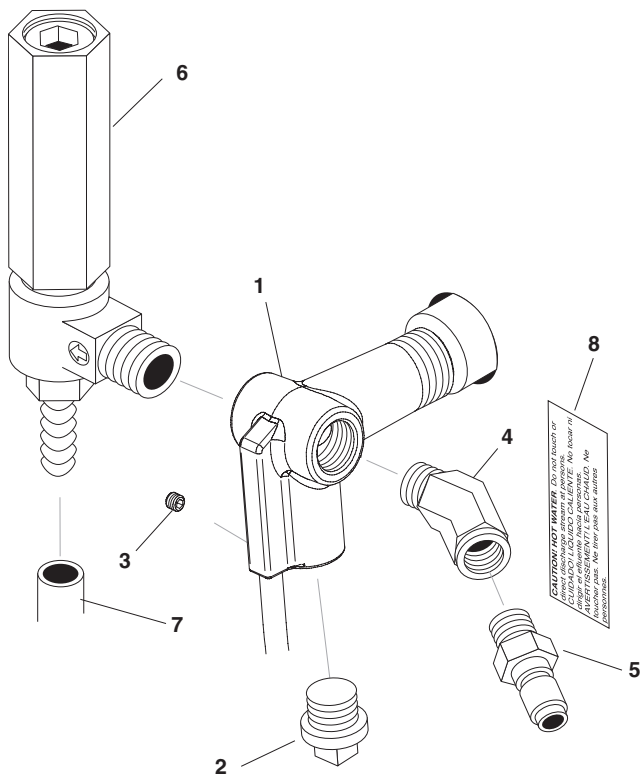

ITEM	PART NO.	DESCRIPTION	QTY
1	8.757-240.0	Manifold coil outlet discharge w/slnt	1
2	8.757-241.0	Plug 3/8 NPTF allen counter sunk w/slnt	1
3	9.196-012.0	Screw, 10-24 x 1/4" Hex Set	1
4	8.757-551.0	Elbow Street Steel 3/8" 45°	1
5	9.802-171.0	Coupler, 3/8" Plug, Male, Steel / Zinc	1
6	8.902-433.0	Valve, Safety Relief VSP	1
7	8.711-785.0	Hose, 3/8" Push On, Per Ft	32"
8	9.800-021.0	Label, Hot Water Outlet	1

## HOSE & SPRAY GUN ASSEMBLY AND PARTS LIST

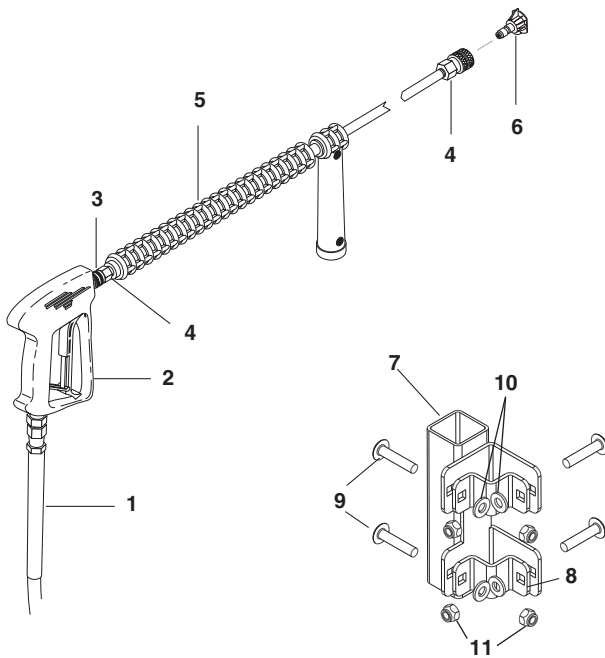

ITEM	PART NO.	DESCRIPTION	QTY
1	8.739-011.0	Hose, 3/8 x 50', 1W, Hotsy, So x Sw	1
2	8.751-235.0	Gun, Hotsy, H1050, 5000 PSI, 10.4 GPM	1
3	8.707-139.0	Coupler, 1/4" Plug, Male, Steel/Zinc	1
4	9.802-164.0	Coupler, 1/4" Socket, Female, Brass	2
5	8.725-388.0	Wand, Single, 48" Insulated W/ Side Grip	1
6	8.712-338.0	Nozzle, Sacqmeg, 1503.5, Yellow	1
	8.712-340.0	Nozzle, Sacqmeg, 4003.5, White	1
7	8.931-243.0	Bracket, Hose Reel Mnt-04	1
8	8.915-292.0	Hose Reel Bracket Mount Retainer	2
9	8.718-623.0	Bolt, 5/16"-18 x 1-1/2", Nc Crge Zinc	4
10	8.718-980.0	Washer, 5/16" Flat, Sae	4
11	9.802-776.0	Nut, 5/16, Esna, Nc	4

## VBT UNLOADER VALVE EXPLODED VIEW

8.754-696.0 VBA

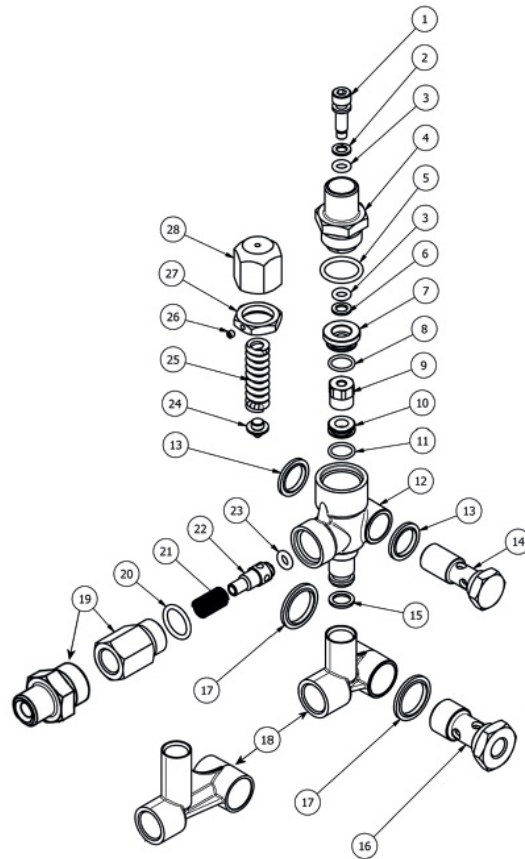

### VBT UNLOADER VALVE VIEW PARTS LIST

ITEM	PART #	DESCRIPTION	QTY	ITEM	PART #	DESCRIPTION	KIT	QTY
1*	8.754-929.0	Stem	1	18	8.754-937.0	Bypass Manifold (696.0, 700.0, 702.0)		1
2*	9.803-912.0	Backup Ring	1		8.754-938.0	Bypass Manifold (701.0)		1
3*	8.754-930.0	O-ring, Ø2.62 x 6.02	2		8.754-958.0	Bypass Manifold (703.0)		1
4	8.730-882.0	Stem Connector (696.0, 703.0)	1	19	9.802-892.0	Outlet Connector 3/8 MPT (696.0, 700.0, 703.0)		1
	9.803-911.0	Stem Connector (700.0, 701.0, 702.0)	1		9.803-914.0	Outlet Connector 3/8 FPT (701.0, 702.0)		1
5*	9.803-193.0	O-ring, Ø2.62 x 20.24	1	20*	9.803-191.0	O-ring, Ø2.62 X 17.13		1
6*	9.803-908.0	Backup Ring	1	21*	8.933-017.0	Poppet Spring		1
7	9.803-907.0	Guide Bushing	1	22*	8.754-939.0	Poppet		1
8*	9.803-906.0	O-ring, Ø1.78 x 14	1	23*	8.754-940.0	O-ring, Ø3 x 6		1
9*	8.754-959.0	Ball SubAssembly (696.0, 703.0)	1	24*	8.754-961.0	Plate (696.0, 703.0)		1
	8.754-932.0	Ball Subassembly (700.0, 701.0, 702.0)	1		9.803-922.0	Plate (700.0, 701.0, 702.0)		1
10*	8.754-933.0	Seat	1	25*	8.730-870.0	Spring 1500-3000 PSI (700.0, 701.0, 702.0)		1
11*	8.754-934.0	O-ring, Ø1.78 x 12.42	1		8.933-018.0	Spring 1500-4000 PSI (696.0, 703.0)		1
12	8.754-935.0	Valve Body	1	26	8.933-021.0	Set Screw		1
13	9.802-893.0	Seal Washer 3/8	1	27		O-Ring 15 ID x 2CS	A,B	3
14	9.803-919.0	Banjo Bolt 3/8	1	28	8.706-865.0	Plug, 1/4" Countersunk		1
15*	8.754-936.0	O-ring, Ø2.62 x 10.78	1	<b>Kit A</b>	9.104-038.0	O-Ring Repair Kit		
16	9.803-920.0	Banjo Bolt 1/2, w1/4" Port	1	<b>Kit B</b>	9.104-039.0	Outlet Kit		
	9.803-920.0	Banjo Bolt w1/4" Port (703.0)	1	<b>Kit C</b>	9.104-040.0	Stem Repair Kit		
17	9.803-914.0	Seal Washer 1/2 (696.0, 700.0, 701.0, 702.0)	1					
	9.802-893.0	Seal Washer, 3/8 (703.0)	1					



# PUMP ASSEMBLY - 871SS

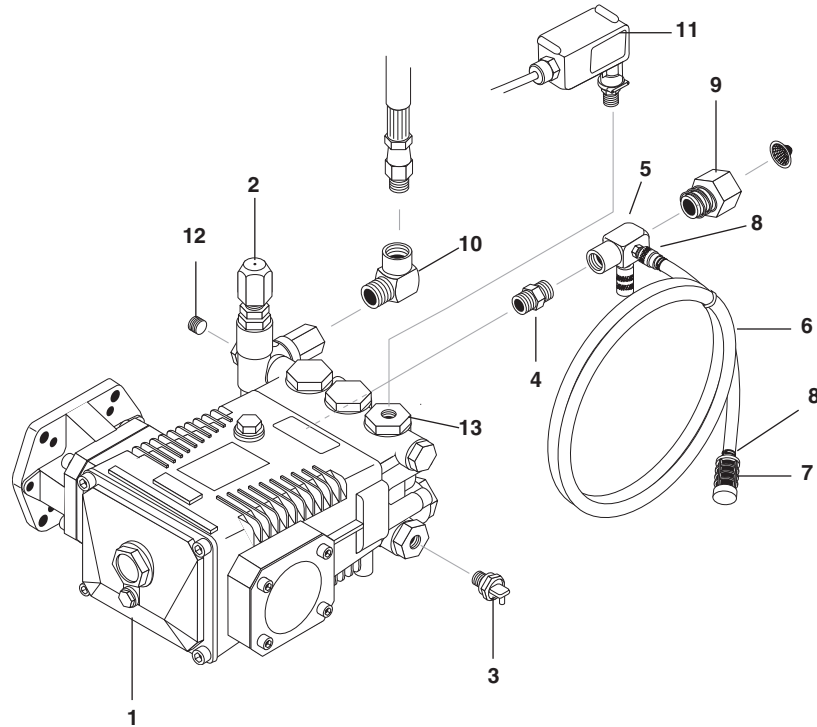

## PUMP PARTS LIST - 871SS

ITEM	PART NO.	DESCRIPTION	QTY
1	8.929-271.0	Pump HOTSY HPP2735G, 3.0@3500, 3400 RPM	1
2	8.754-696.0	Unloader, VBT Banjo 1/2M 3/8M, 3000PSI	1
3	8.757-549.0	Pump protector 1/2 140°	1
4	8.706-880.0	Nipple, 1/2" Mpt x 3/8" Mpt Brass	1
5	9.803-275.0	Injector Adjustable, Inlet Hotsy	1
6	9.802-252.0	Hose, 1/4" x 1/2", Braided Vinyl/Ft	4 ft
7	8.707-056.0	Strainer, Chemical W/1/4" Brass Barb	1
8	6.390-126.0	Clamp, Hose, .46-.54 St	2
9	9.802-417.0	Swivel, 3/8" Mp x 3/4" Ghf W/Strainer	1
10	8.757-935.0	Adapter steel 1/2 JIC x 3/8 NPTF (F) 90°	1
11	9.802-458.0	Switch, Pressure N/O, 1/4 Npt SS	1
12	8.757-192.0	Plug, 1/4" Nptf Countersunk Brass	1
13	9.804-022.0	Cap, Valve 22mm, W 1/4" Gauge	1

## LPP SERIES PUMP EXPLODED VIEW

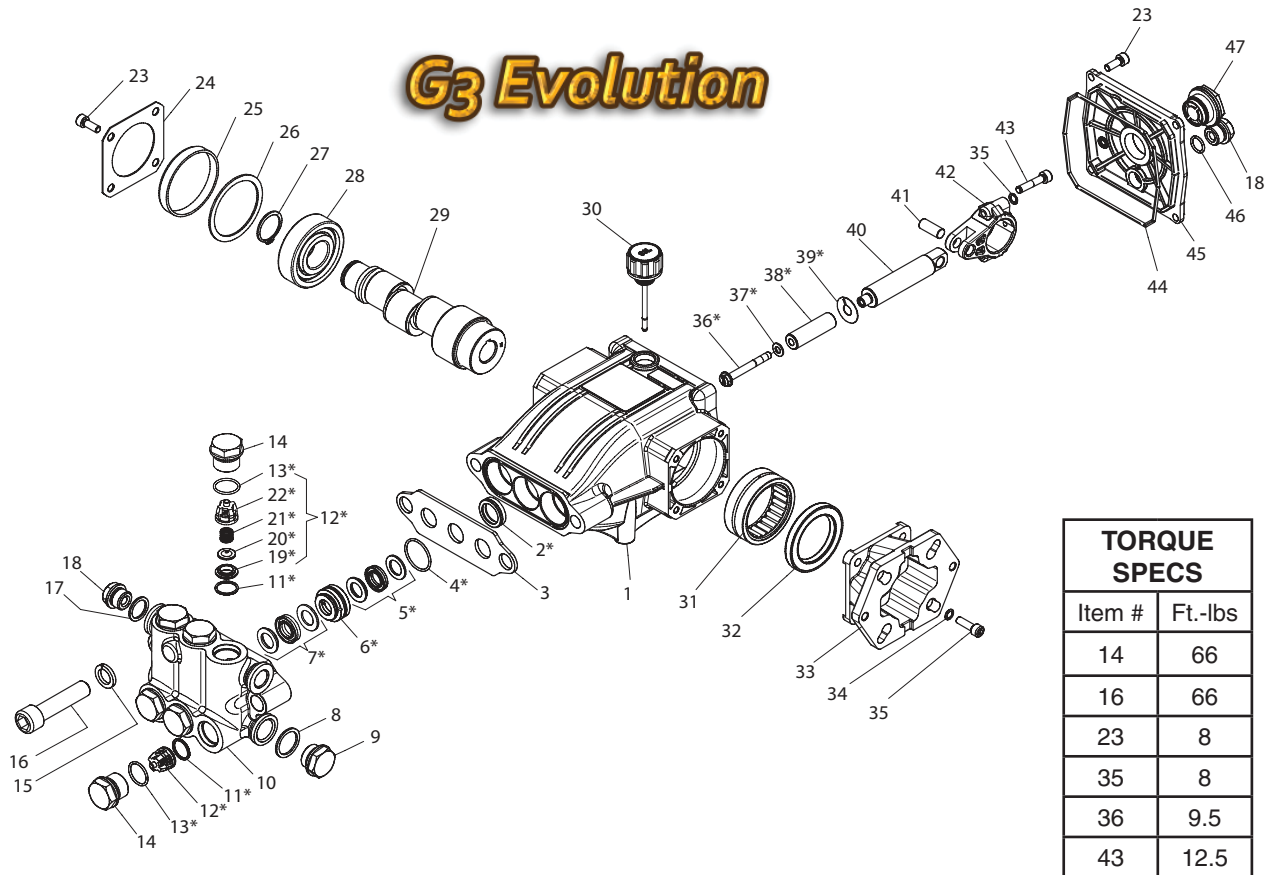

## LPP SERIES PUMP EXPLODED VIEW PARTS LIST

ITEM	PART NO.	DESCRIPTION	QTY	ITEM	PART NO.	DESCRIPTION	QTY
1	8.754-841.0	Crankcase	1	19*	See Kits Below	Valve Seat	6
2*	See Kits Below	Plunger Oil Seal	3	20*	See Kits Below	Valve Seat	6
3	8.758-216.0	Spacer	1	21*	See Kits Below	Valve Plate	6
4*	See Kits Below	"O" Ring Ø1.78X26.7	3	22*	See Kits Below	Valve Spring	6
5*	See Kits Below	"U" Seal, DIA. 14 MM	3	23	9.802-939.0	Screw M6X16	8
6*	See Kits Below	Pressure Ring Dia. 14 mm	3	24	8.717-137.0	Bearing Cover	2
7*	See Kits Below	"U" Seal, Dia. 14 mm	3	25	9.803-954.0	Bearing Seal	1
8	9.803-199.0	Copper Washer g1/2	1	26	8.754-843.0	Crankshaft Seal Spacer	1
9	9.802-926.0	Brass Plug g1/2	1	27	9.802-914.0	Snap Ring Dia. 25 mm	1
10	8.759-027.0	Manifold Housing	1	28	9.803-955.0	Ball Bearing	1
11*	8.717-233.0	"O" Ring ø1.78x15.6	6	29	8.754-831.0	Hollow Shaft 2735G	1
12*	See Kits Below	Valve Assembly	6		8.754-834.0	Hollow Shaft 3035G	1
13*	9.803-948.0	"O" Ring ø1,78x18.77	6	30	8.754-219.0	Oil Dip Stick	1
14	9.803-949.0	Valve Plug	6	31	8.754-840.0	Needel Roller Bearing	1
15	8.754-850.0	Lock-Washer	2	32	8.754-826.0	Crankshaft Seal	1
16	8.758-217.0	Manifold Stud Bolt M14X60	2	33	8.754-863.0	Motor Flange	1
17	9.803-198.0	Copper Washer g3/8	1	34	9.803-218.0	Spring Washer Dia. 6 mm	10
18	8.707-262.0	Brass Plug g 3/8	2	35	8.752-824.0	Screw m6x20	4
				36*	8.754-855.0	Plunger bolt	3

## LPP SERIES PUMP EXPLODED VIEW PARTS LIST (CONT)

ITEM	PART NO.	DESCRIPTION	QTY
37*	8.754-092.0	Bonded Seal - ø6,7x11x1 AISI 304	3
38*	8.754-849.0	Plunger Dia. 14 mm	3
39*	9.803-962.0	Copper Spacer	3
40	8.759-032.0	Plunger Rod	3
41	9.803-965.0	Connecting Rod Pin	3
42	9.803-966.0	Connecting Rod	3
43	8.933-020.0	Connecting Rod Screw	6
44	8.754-847.0	"O" Ring ø2.62X111.62	1
45	8.754-842.0	Crankcase Cover	1
46	9.803-906.0	"O" Ring ø1.78X14	1
47	9.803-202.0	Sight Glass G3/4	1

\* Available in kit (See below)

REPAIR KIT NUMBER	8.759-031.0	8.758-218.0	8.754-862.0	8.754-859.0	9.803-937.0
KIT DESCRIPTION	Plunger Seal 14mm	Seal Packing 14 mm	Plunger 14 mm	Complete Valve	Plunger Oil Seals
ITEM NUMBERS INCLUDED	4, 5, 7, 16	4, 5, 6, 7, 16	36, 37, 38, 39	11, 12, 14	2
NUMBER OF CYLINDERS KIT WILL SERVICE	3	3	1	6	3

# WAYNE BURNER EXPLODED VIEW

## Replacement Parts

For best performance specify genuine WAYNE replacement parts

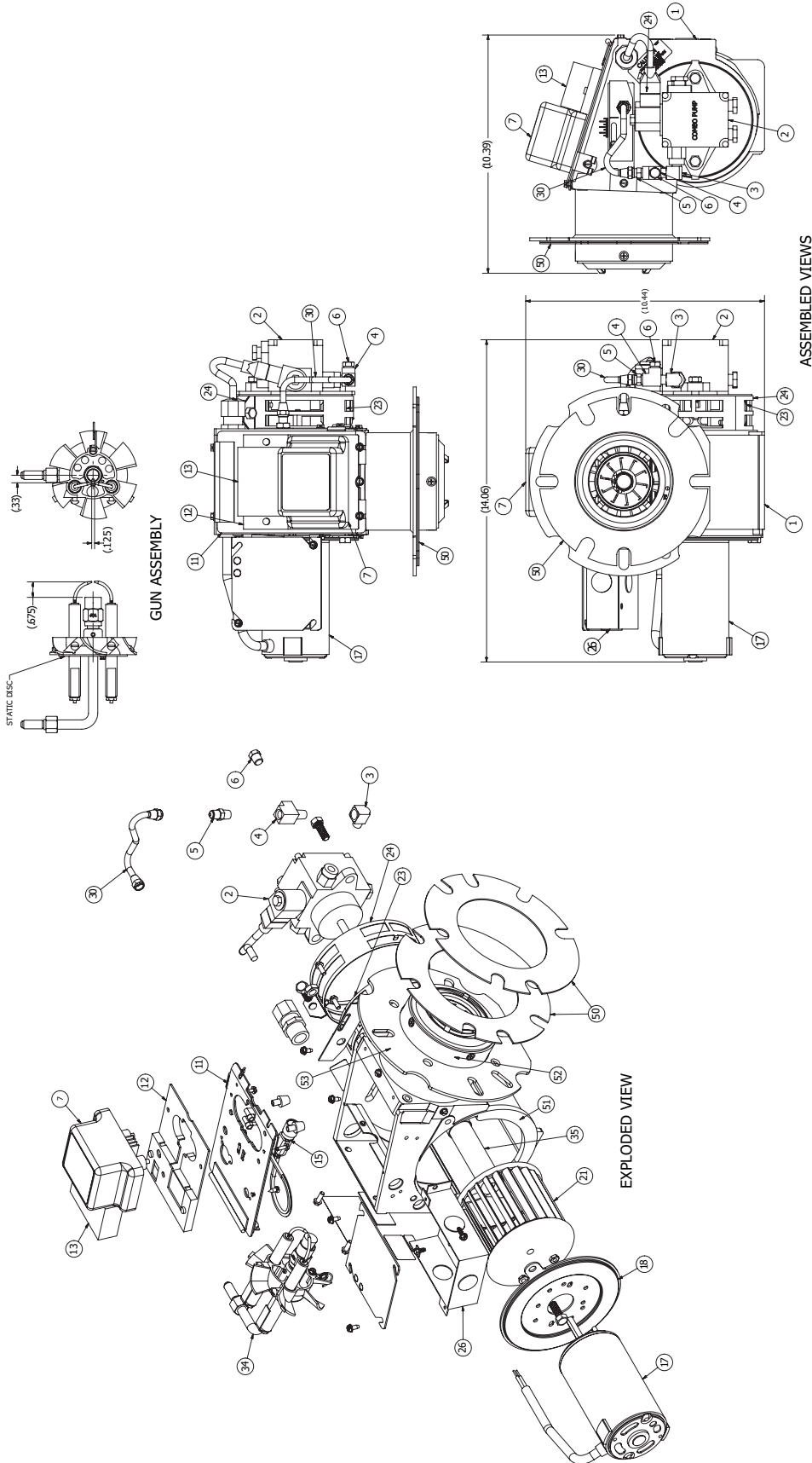

## WAYNE BURNER PARTS LIST

### Replacement Parts

*For best performance specify genuine WAYNE replacement parts*

ITEM	PART NO.	DESCRIPTION	QTY
1	101409-001	Tube/Hous-101393-001/3A/3.75"/.88"l	1
2	8.756-437.0	Pump-Combo/W Solenoid 12V/24V	1
3	550053	Fitting, Elbow 90° Street 1/8	1
4	101274-001	Tee,Street-1/8 X 1/8 Brass	1
5	14222	Connector, Male-3/16" X 1/8" IPT	1
6	15766	Plug, Pipe HXHD 1/8" NPT	1
7	9.701-507.0	Ignitor - MSR 12V LA	1
11	21723-014	Cover, Hous-M CAD MTG & Gasket	1
12	101309-002	Base, Mounting-Ignitor CC Timer	1
13	8.756-661.0	Timer, Drop-Out	1
15	8.700-819.0	Cad Cell F/HS & M Series Burner	1
17	8.700-739.0	Motor, 12VDC 1/8 HP LOWAMP/3950RPM	1
18	100761-001	Sideplate, Housing-MSR 12VDC	1
21	8.756-674.0	Fan-3.44"W X 4.25"D 5/16" Bore	1
23	8.700-707.0	Air Band Inner "M"	1
24	8.717-826.0	Air Band Outer 8 Hole "M"	1
26	8.756-295.0	Junction Box, MSR	1
28	13392	Plate, Slot Cover	1
30	8.700-704.0	Oil Line Assembly 6"	1
34	8.756-297.0	Gun Assembly, Burner-RG/*CST/*1 1/4"BB	1
35	8.700-721.0	Coupling, "M" DC	1
50	8.700-692.0	Flange Gasket (2 Each)	2
51	8.717-939.0	Burner Fan Housing "M" Drilled	1
52	8.700-701.0	Air Cone #3A	1
53	8.756-303.0	Air Tube Flange Welded .88" "MSR"	1

# WIRING DIAGRAM - 871SS

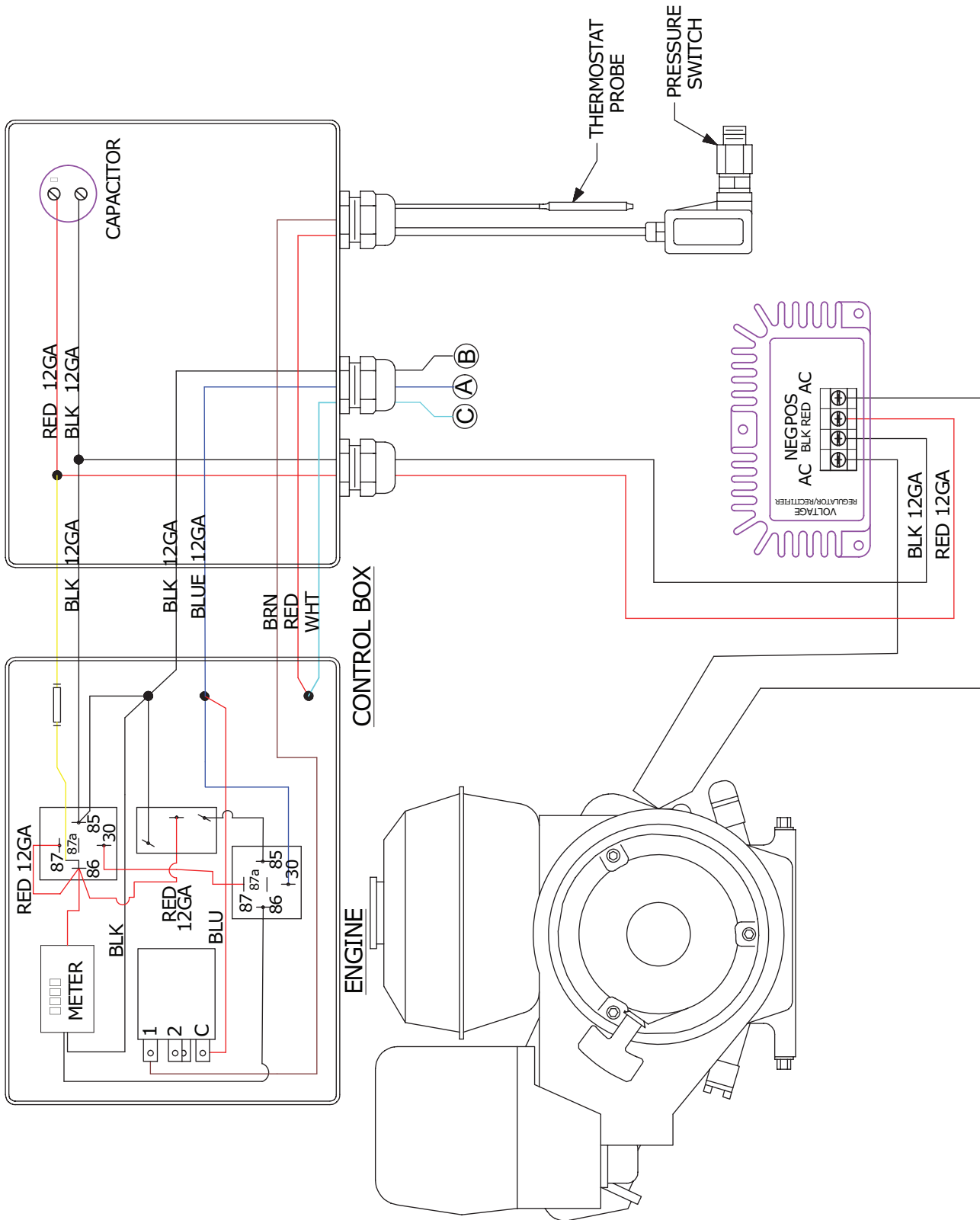

# WIRING DIAGRAM - 871SS

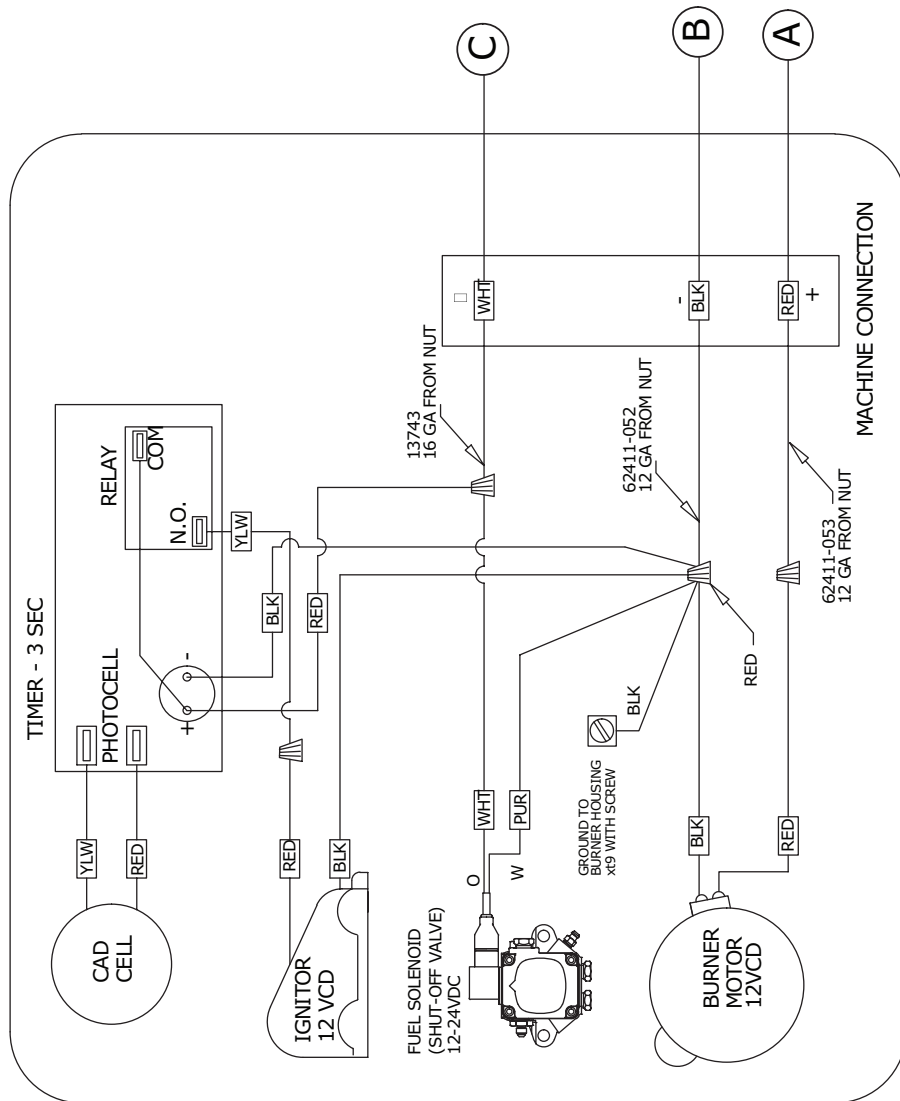

1. APPLIED 12V ENERGIZES  
 -BURNER MOTOR WHICH STARTS FUEL FLOW  
 -SHUT OFF VALVE WHICH ALLOWS FUEL TO FLOW OUT OF PUMP  
 -3 SEC, TIMER ENERGIZES THE IGNITOR TO IGNITE FUEL
2. AFTER 3 SEC, TIMER DE-ENERGIZES THE IGNITOR (RESISTOR JUMPER)  
 ON PHOTOCELL ELIMINATES RE-ENERGIZING IGNITOR IF FLAME IS LOST
3. AFTER 12V HAVE BEEN REMOVED  
 -BURNER MOTOR IS DE-ENERGIZED WHICH STOPS FUEL FLOW  
 -SHUT OFF VALVE IS DE-ENERGIZED WHICH STOPS FUEL FLOW OUT OF PUMP  
 -3 SEC TIMER IS DE-ENERGIZED
4. SEQUENCE STARS AGAIN WHEN 12V APPLIED

If you need **SERVICE** on your pressure washer, contact your local Hotsy dealer or visit [www.Hotsy.com](http://www.Hotsy.com). Smart phone users scan the code below to link directly to the Service Request page.



To **REGISTER** your pressure washer, please visit our Warranty Registration page at [www.hotsy.com/WarrantyRegistration.aspx](http://www.hotsy.com/WarrantyRegistration.aspx) or scan the code below with your smart phone.

