

PHW

Hot Water - Electric Powered - Diesel/Oil Heated

LANDA®

Operator's Manual

Pressure Washer

MODELS: **PHW3-11024**
 1.109-078.0

PHW4-22024
 1.109-079.0

PHW4-30024
 1.109-085.0

PHW4-22024
 1.109-091.0



SHOP PRESSURE WASHER PARTS

shoppressurewasherparts.com | 888.269.0172



Intertek



8.917-417.0-D 03/10/20

Machine Data Label

Model: _____

Date of Purchase: _____

Serial Number: _____

Dealer: _____

Address: _____

Phone Number: _____

Sales Representative: _____

Machine Data Label2
Table of Contents3
How To Use This Manual4

Safety

Introduction & Safety Information5
Important Safety Information.6

Operations

Component Identification9
Assembly Instructions10
Operation Instructions11
Detergents & General Cleaning Techniques12
Thermal Pump Protection12
Shutdown Instructions13
Storage13

Maintenance

Preventative Maintenance14

Maintenance And Service14

Pump Lubrication14
Fuel14
Electrode Setting14
Transformer Check14
Fuel Control System14
Fuel Pressure Adjustment.14
Wayne Oil Burner15
Fuel Pressure Adjustment.15
Burner Air Adjustment.15
Cleaning of Coils.16
Spray Nozzles.16
Unloader Valves16
Winterizing Procedure.16
Low Pressure Diagnosis16
Coil Removal.17
Temperature and Pressure Relief Valve.17
Optional Time Delay Shutdown Operation17
Optional Auto Start/stop Timer Operation.17
Maintenance Schedule18
Oil Change Record19
Troubleshooting20

How To Use This Manual

This manual contains the following sections:

- How to Use This Manual
- Safety
- Operations
- Maintenance

The HOW TO USE THIS MANUAL section will tell you how to find important information for ordering correct repair parts.

Parts may be ordered from authorized dealers. When placing an order for parts, the machine model and machine serial number are important. Refer to the MACHINE DATA box which is filled out during the installation of your machine. The MACHINE DATA box is located on the inside of the front cover of this manual.

Model: _____
Date of Purchase: _____
Serial Number: _____
Dealer: _____
Address: _____
Phone Number: _____
Sales Representative: _____

The model and serial numbers will be found on a decal attached to the pressure washer.

The SAFETY section contains important information regarding hazardous or unsafe practices of the machine. Levels of hazards are identified that could result in product damage, personal injury, or severe injury resulting in death.

The OPERATIONS section is to familiarize the operator with the operation and function of the machine.

The MAINTENANCE section contains preventive maintenance to keep the machine and its components in good working condition. They are listed in this general order:

- Preventative Maintenance
- Maintenance And Service
- Pump Lubrication
- Fuel
- Burner Air Adjustment
- Cleaning of Coils
- Spray Nozzles
- Unloader Valves
- Winterizing Procedure
- Low Pressure Diagnosis
- Coil Removal
- Temperature and Pressure Relief Valve
- Optional Time Delay Shutdown Operation
- Optional Auto Start/Stop Timer Operation
- Maintenance Schedule
- Oil Change Record
- Troubleshooting

The PARTS LIST section contains assembled parts illustrations and corresponding parts list. The parts lists include a number of columns of information:

- **REF** – column refers to the reference number on the parts illustration.
- **PART NO.** – column lists the part number for the part.
- **QTY** – column lists the quantity of the part used in that area of the machine.
- **DESCRIPTION** – column is a brief description of the part.
- **NOTES** – column for information not noted by the other columns.

NOTE: If a service or option kit is installed on your machine, be sure to keep the KIT INSTRUCTIONS which came with the kit. It contains replacement parts numbers needed for ordering future parts.

NOTE: The manual part number is located on the lower right corner of the front cover.

Introduction & Safety Information

Thank you for purchasing this Pressure Washer.

We reserve the right to make changes at any time without incurring any obligation.

Owner/User Responsibility:

The owner and/or user must have an understanding of the manufacturer's operating instructions and warnings before using this pressure washer. Warning information should be emphasized and understood. If the operator is not fluent in English, the manufacturer's instructions and warnings shall be read to and discussed with the operator in the operator's native language by the purchaser/owner, making sure that the operator comprehends its contents.

Owner and/or user must study and maintain for future reference the manufacturers' instructions.

The operator must know how to stop the machine quickly and understand the operation of all controls. Never permit anyone to operate the engine without proper instructions.

SAVE THESE INSTRUCTIONS

This manual should be considered a permanent part of the machine and should remain with it if machine is resold.

When ordering parts, please specify model and serial number. Use only identical replacement parts.

This machine is to be used only by trained operators.

Important Safety Information



WARNING: To reduce the risk of injury, read operating instructions carefully before using.

AVERTISSEMENT: Pour réduire le risque de blessures, lire attentivement les instructions de fonctionnement avant l'utilisation

1. Read the owner's manual thoroughly. Failure to follow instructions could cause malfunction of the machine and result in death, serious bodily injury and/or property damage.
2. Know how to stop the machine and bleed pressure quickly. Be thoroughly familiar with the controls.
3. Stay alert — watch what you are doing.
4. All installations must comply with local codes. Contact your electrician, plumber, utility company or the selling dealer for specific details. If your machine is rated 250 volts or less, single phase a ground fault circuit interrupter (GFCI) will be provided. If rated more than 250 volts, or more than single phase this product should only be connected to a power supply protected by a GFCI.

DANGER: Improper connection of the equipment-grounding conductor can result in a risk of electrocution. Check with a qualified electrician or service personnel if you are in doubt as to whether the outlet is properly grounded. Do not modify the plug provided with the product - if it will not fit the outlet, have a proper outlet installed by a qualified electrician. Do not use any type of adaptor with this product

DANGER: Une mauvaise connexion du conducteur de terre de l'équipement peut entraîner un risque d'électrocution. Vérifier auprès d'un électricien qualifié ou du personnel d'entretien si vous avez des doutes quant à savoir si la sortie est correctement mise à la masse. NE PAS modifier la fiche fournie avec le produit - si elle n'entre pas dans la sortie, faire installer une sortie appropriée par un électricien qualifié. NE JAMAIS utiliser un adaptateur avec ce produit.



WARNING: Keep wand, hose, and water spray away from electric wiring or fatal electric shock may result.

AVERTISSEMENT: Garder la lance, le boyau et le jet d'eau à l'écart de tout câblage électrique ou des chocs électriques mortels pourraient survenir

5. To protect the operator from electrical shock, the machine must be electrically grounded. It is the responsibility of the owner to connect this machine to a UL grounded receptacle of proper voltage and amperage ratings. Do not spray water on or near electrical components. Do not touch machine with wet hands or while standing in water. Always disconnect power before servicing.

WARNING: Flammable liquids can create fumes which can ignite, causing property damage or severe injury.

AVERTISSEMENT: Des liquides inflammables peuvent produire des vapeurs qui peuvent s'enflammer, causant ainsi des dommages à la propriété ou des blessures graves.



WARNING: Risk of explosion — Operate only where open flame or torch is permitted.

AVERTISSEMENT: Risque d'explosion - Utiliser uniquement dans des endroits où l'utilisation d'une flamme nue ou d'une torche est permise.

6. In oil burning models, use only kerosene, No. 1 home heating fuel, or diesel. If diesel is used, add a soot remover to every tankful.



WARNING: Risk of fire — Do not add fuel when the product is operating or still hot.

AVERTISSEMENT: Risque d'incendie - Ne pas ajouter de carburant pendant que la machine fonctionne ou est encore chaude.

WARNING: Do not use gasoline crankcase draining or oil containing gasoline, solvents or alcohol. Doing so will result in fire and/or explosion.

AVERTISSEMENT: Ne pas utiliser d'essence, de

drainage du carter de moteur ou d'essence contenant de l'huile, de solvants ou de l'alcool. Agir de la sorte risquerait de créer un incendie et/ou une explosion.

7. Oil burning appliances shall be installed only in locations where combustible dusts and flammable gases or vapors are not present. Do not store or use gasoline near this machine.
8. Do not allow acids, caustic or abrasive fluids to pass through the pump.
9. Never run pump dry or leave spray gun closed longer than 1-2 minutes.
10. Keep operating area clear of all persons.



WARNING: High pressure spray can cause paint chips or other particles to become airborne and fly at high speeds. To avoid personal injury, eye, hand and foot safety devices must be worn.

AVERTISSEMENT: Un jet haute pression peut écailler la peinture ou provoquer l'émission d'autres particules dans l'air et leur projection à hautes vitesses. Pour éviter les lésions corporelles, une protection des yeux, du visage, des mains et des pieds doit être portée lors de l'utilisation de cet équipement

11. Always wear properly rated eye protection such as safety goggles or face shield while spraying. (Safety glasses do not provide full protection.)

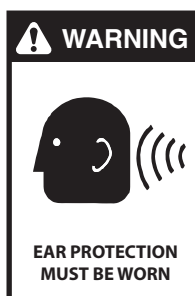

WARNING: This machine exceeds 85 db appropriate ear protection must be worn.

AVERTISSEMENT: Cette machine excède 85 dB et une protection de l'ouïe appropriée doit être portée.



WARNING: Hot discharge fluid. Do not touch or direct discharge stream at persons or animals or severe injury or death will result.

AVERTISSEMENT: Liquide de décharge chaud. Ne pas toucher ou décharger directement le jet vers des personnes ou des animaux, car cela risquerait de

causer des blessures graves ou même la mort.

WARNING: This machine produces hot water and must have insulated components attached to protect the operator.

AVERTISSEMENT: Cette machine produit de l'eau chaude et doit comporter des composants isolés attachés pour protéger l'opérateur.



WARNING: Risk of injury. Hot surfaces can cause burns. Use only designated gripping areas of spray gun and wand. Do not place hands or feet on non-insulated areas of the pressure washer.

AVERTISSEMENT: Risque de blessures. Les surfaces chaudes peuvent causer des brûlures. Utiliser uniquement les zones de prise désignées du pistolet pulvérisateur et de la lance. Ne pas placer les mains ou les pieds sur des endroits non isolés de la laveuse à pression.

12. To reduce the risk of injury, close supervision is necessary when a machine is used near children. Do not allow children to operate the pressure washer. **This machine must be attended during operation.**



WARNING: Grip cleaning wand securely with both hands before starting. Failure to do this could result in injury from a whipping wand.

AVERTISSEMENT: Agripper la lance de nettoyage avec les deux mains avant de commencer. Le non-respect de cette consigne pourrait mener à des blessures causées par le mouvement violent de la lance.

13. Never make adjustments on machine while in operation.
14. Be certain all quick coupler fittings are secured before using pressure washer.

Safety



WARNING: High pressure developed by these machines will cause personal injury or equipment damage. Keep clear of nozzle. Use caution when operating. Do not direct discharge stream at people, or severe injury or death will result.

AVERTISSEMENT: La haute pression générée par ces

machines causera des lésions corporelles ou des dommages à l'équipement. Se tenir à l'écart de la buse. Faire preuve de prudence lors de l'utilisation. Ne pas décharger directement le jet vers des personnes ou des animaux, car cela risquerait de causer des blessures graves ou même la mort.



WARNING: Protect machine from freezing.

AVERTISSEMENT: Protéger la machine contre le gel.

15. To keep machine in best operating conditions, it is important you protect machine from freezing. Failure to protect machine from freezing could

cause malfunction of the machine and result in death, serious bodily injury, and/or property damage. Follow storage instructions specified in this manual.

16. Inlet water must be clean fresh water and no hotter than 90°F.



DANGER: Risk of asphyxiation. Use this product only in a well ventilated area. Running this product indoors can result in death due to carbon monoxide, a poisonous gas you cannot see or smell. Never operate indoors even if windows and doors are open. Only use outdoor and far away from windows, doors, and

openings or vents.

DANGER: Risque d'asphyxie. Ne pas inhaler les vapeurs. Utiliser ce produit uniquement dans un endroit bien ventilé. L'utilisation de ce produit à l'intérieur peut causer la mort par monoxyde de carbone, un gaz toxique incolore et inodore. Ne jamais utiliser à l'intérieur, même si les fenêtres et les portes sont ouvertes.

17. Avoid installing machines in small areas or near exhaust fans. Adequate oxygen is needed for combustion or dangerous carbon monoxide will result.

18. Manufacturer will not be liable for any changes made to our standard machines or any components not purchased from us.

19. The best insurance against an accident is precaution and knowledge of the machine.



WARNING: Be extremely careful when using a ladder, scaffolding or any other relatively unstable location. The cleaning area should have adequate slopes and drainage to reduce the possibility of a fall due to slippery surfaces.

AVERTISSEMENT: Faire preuve d'une extrême prudence au moment d'utiliser une échelle,

des échafaudages ou toute autre surface relativement instable. La zone de nettoyage doit avoir une pente et un drainage adéquats pour réduire la possibilité d'une chute due à une surface glissante.

20. Do not overreach or stand on unstable support. Keep good footing and balance at all times.

21. Do not operate this machine when fatigued or under the influence of alcohol, prescription medications, or drugs.



WARNING: Do not spray machine or any people, animals or electrical parts.

AVERTISSEMENT: Ne pas vaporiser sur la machine ou les gens, les animaux ou les pièces électriques.



Follow the maintenance instructions specified in the manual.

Suivre les instructions d'entretien spécifiées dans le manuel.

Component Identification

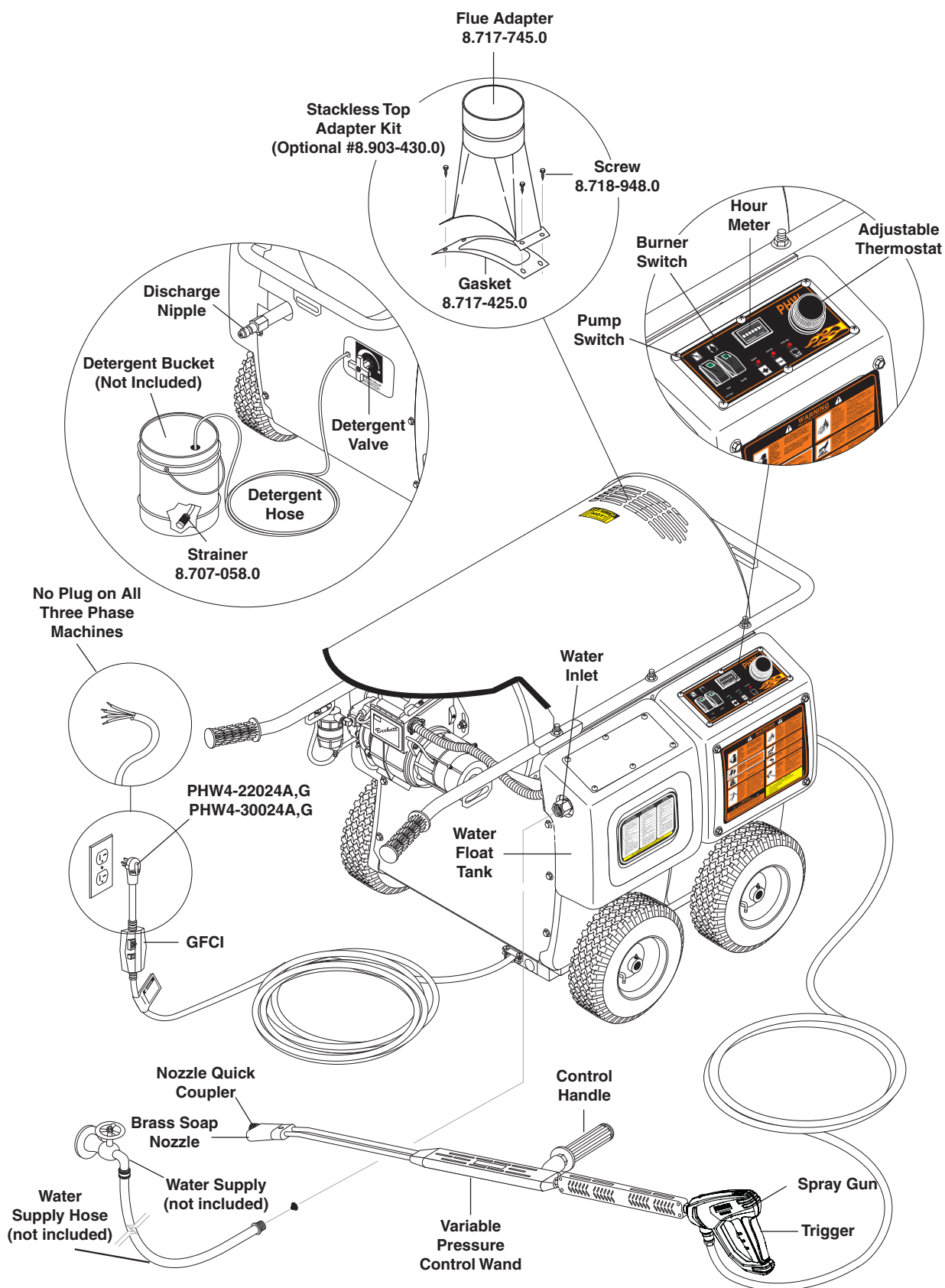

Operations

Assembly Instructions

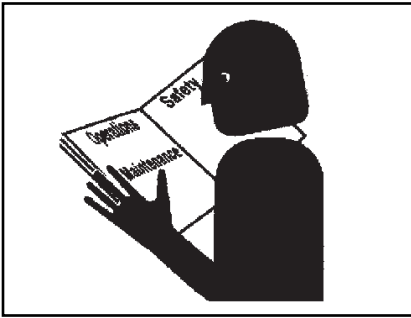

STEP 1: Read safety, installation and preventative maintenance instructions before connecting the water supply hose to the float tank inlet swivel connector and turning on water supply.

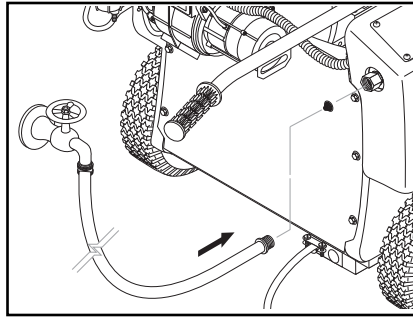

STEP 2: Water source for machines should be supplied by a 3/4" I.D. garden hose with a city water pressure of not less than 30 PSI. If the water supply is inadequate, or if the garden hose is kinked, the machine will run very rough and the burner will not fire.

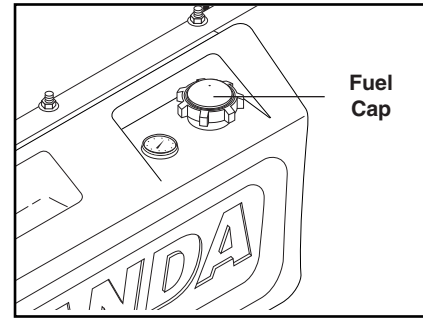

STEP 3: Fill fuel tank with proper fuel: kerosene, No. 1 home heating fuel or diesel.

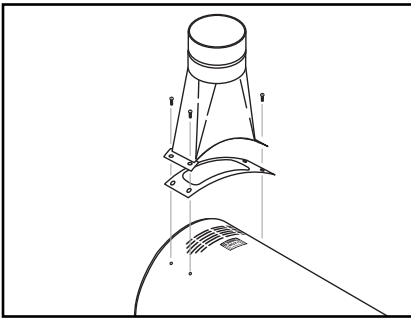

STEP 4: Adding exhaust vent pipe to your oil fired burner is not recommended because it restricts air flow. This causes carbon build-up, which affects the operation and increases maintenance on the coil. If a stack must be used, refrain from using 90° bends. If the pipe can not go straight up then use only 45° bends and go to the next larger size pipe. The overall pipe length must not exceed 6 feet in length. Air adjustments will be required after installation.

Operation Instructions

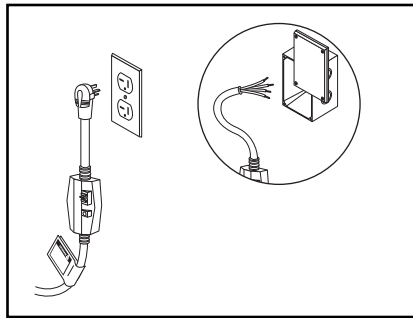

STEP 1: Machines must be stored indoors when not in use. Location of machine is important. Avoid installing near combustible material or in poorly ventilated areas. Electrical connection to machine should be the proper voltage, phase and amperage. See specifications for particular model. Plug the power cord into a **grounded receptacle**.

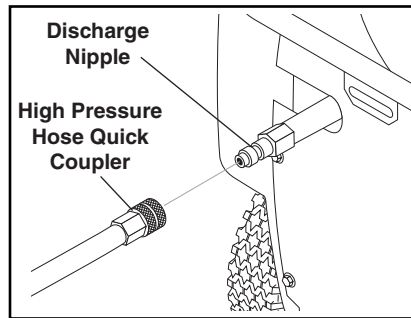

STEP 2: Connect the high pressure hose quick coupler to discharge nipple by sliding the quick coupler collar back and inserting quick coupler on to discharge nipple and pushing the quick coupler collar forward to secure it.

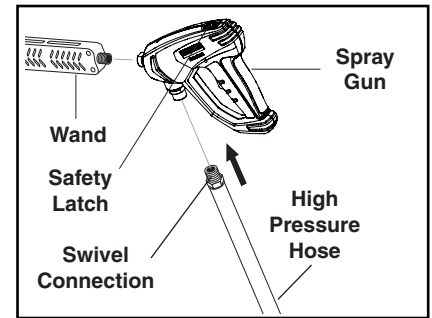

STEP 3: Attach wand to spray gun using teflon tape on threads to prevent leakage. Attach swivel connector on high pressure hose to spray gun using teflon tape on threads. Engage safety latch to prevent from triggering gun.

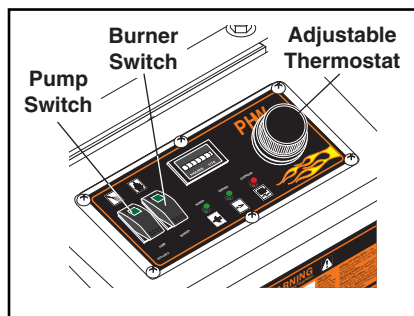

STEP 4: Press the pump switch "ON" and then pull the trigger on the spray gun to activate pressure switch which starts machine (For auto start machines only).

For machines with time delay shut down, simply press pump switch "ON" and the machine will start.

Before installing nozzle, turn on water supply and run machine allowing water to flush through the system until clear.

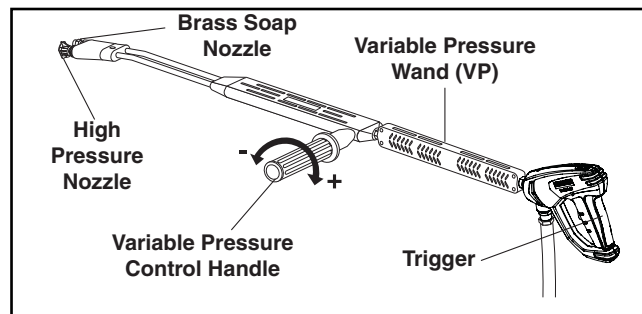

STEP 5: Selection of high or low pressure is accompanied by turning the handle. **Note:** High pressure nozzle must be inserted at end of wand to obtain high pressure. To apply soap, see Detergent and General Cleaning Techniques section.

When a steady stream of water flows from the spray gun and wand, turn the thermostat knob to the 200° mark, then push the burner switch. The burner will light automatically when the spray gun trigger is pulled.

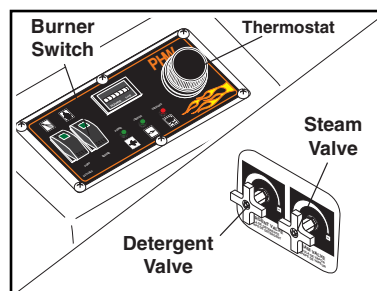

STEP 6: STEAM COMBINATION

OPTION: Turn the steam valve counter-clockwise. (Detergent will not siphon when the steam valve is opened.)

Turn burner switch off, pull trigger on spray gun and allow water to cool.

Operations

Detergents & General Cleaning Techniques



WARNING: Some detergents may be harmful if inhaled or ingested, causing severe nausea, fainting or poisoning. The harmful elements may cause property damage or severe injury.

AVERTISSEMENT: Certains détergents peuvent être dangereux s'ils sont inhalés ou ingérés, provoquant de fortes nausées, des évanouissements et l'empoisonnement. Les éléments dangereux peuvent causer des dommages à la propriété ou des blessures graves.

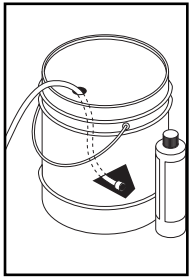

STEP 1: Use Landa detergent designed specifically for pressure washers. Household detergents could damage the pump. Prepare detergent solution as required by the manufacturer. Fill a container with pressure washer detergent. Place the filter end of detergent pick-up tube into the detergent container.

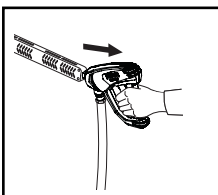
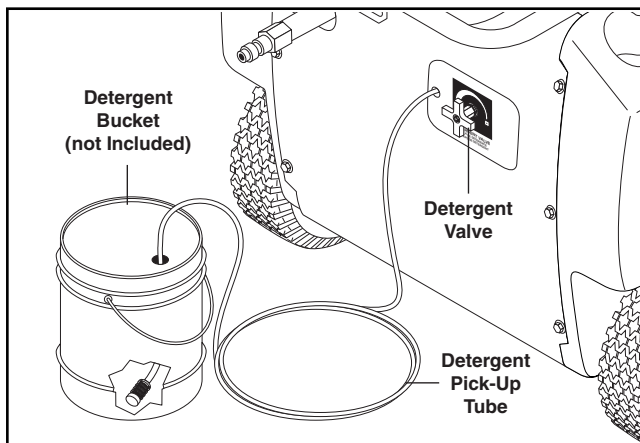

STEP 2: Turn detergent valve counterclockwise until desired amount of detergent flow is achieved.

STEP 3: With the motor running, pull trigger to operate machine.

Liquid detergent is drawn into the machine and mixed with water. Apply detergent to work area. Do not allow detergent to dry on surface.

IMPORTANT: You must flush the detergent after each use by placing the suction tube into a bucket of clean water. Then run the pressure washer for 1-2 minutes. Turn detergent valve clockwise after flushing with clean water to prevent air from entering pump.

Thermal Pump Protection

If you run your pressure washer for 3 minutes without pressing the trigger on the spray gun, circulating water in the pump can reach high temperatures. When the water reaches this temperature, the pump protector engages and cools the pump by discharging the warm water onto the ground. This thermal device prevents internal damage to the pump.

Cleaning Tips

Pre-rinse cleaning surface with fresh water. Place detergent suction tube directly into cleaning solution and apply to surface at low pressure (for best results, limit your work area to sections approximately 6 feet square and always apply detergent from bottom to top). Allow detergent to remain on surface 1-3 minutes. Do not allow detergent to dry on surface. If surface appears to be drying, simply wet down surface with fresh water. If needed, use brush to remove stubborn dirt. Rinse at high pressure from top to bottom in an even sweeping motion keeping the spray nozzle approximately 1 foot from cleaning surface. Use overlapping strokes as you clean and rinse any surface. For best surface cleaning action spray at a slight angle.

Recommendations:

- Before cleaning any surface, an inconspicuous area should be cleaned to test spray pattern and distance for maximum cleaning results.
- If painted surfaces are peeling or chipping, use extreme caution as pressure washer may remove the loose paint from the surface.
- Keep the spray nozzle a safe distance from the surface you plan to clean. High pressure wash a small area, then check the surface for damage. If no damage is found, continue to pressure washing.

CAUTION - Never use:

- Bleach, chlorine products and other corrosive chemicals
- Liquids containing solvents (i.e., paint thinner, gasoline, oils)
- Tri-sodium phosphate products
- Ammonia products
- Acid-based products

These chemicals will harm the machine and will damage the surface being cleaned.

Rinsing

It will take a few seconds for the detergent to clear. Apply safety latch to spray gun. Remove black soap nozzle from the quick coupler. Select and install the desired high pressure nozzle. **NOTE:** You can also stop detergent from flowing by simply removing detergent siphon tube from bottle.

Shutdown Instructions

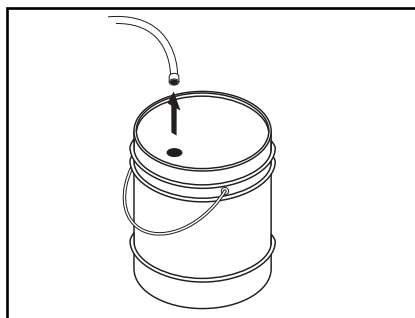

STEP 1: Remove detergent suction tube from container and insert into one (1) gallon of fresh water. Pull trigger on spray gun and siphon water for one minute

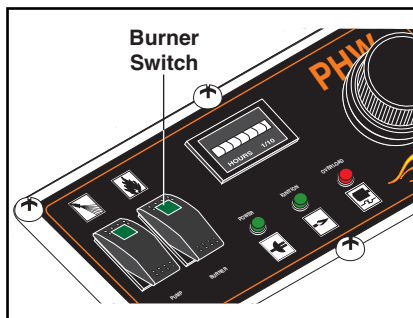

STEP 2: Push burner switch off and open trigger on spray gun, allowing water to flow, which will cool down the heating coil.

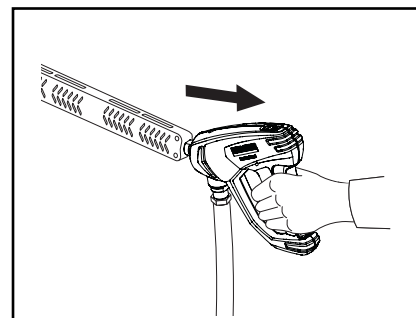

STEP 3: After water has cooled, turn the pump switch off.

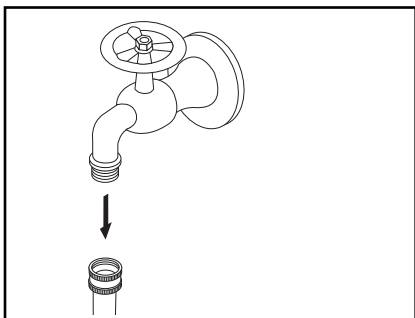

STEP 4: Turn water off.

Storage

CAUTION: Always store your pressure washer in a location where the temperature will not fall below 32° F (0°C). The pump in this machine is susceptible to permanent damage if frozen. **FREEZE DAMAGE IS NOT COVERED BY WARRANTY.**

ATTENTION: Toujours entreposer la laveuse à pression dans un endroit où la température ne sera pas inférieure à X °C (X °F). La pompe sur cette machine est susceptible de subir des dommages si elle est exposée au gel. **LES DOMMAGES DUS AU GEL NE SONT PAS COUVERTS PAR LA GARANTIE.**

1. Stop the pressure washer, squeeze spray gun trigger to release pressure.
2. Detach water supply hose and high pressure hose.
3. Turn on the machine for a few seconds, until remaining water exits. Turn pump off immediately.

4. Do not allow high pressure hose to become kinked.
5. Store the machine and accessories in a room which does not reach freezing temperatures.

CAUTION: Failure to follow the above directions will result in damage to your pressure washer.

ATTENTION: Le non-respect des directives ci-dessus entraînera des dommages à la laveuse à pression.

Maintenance

Preventative Maintenance

- Use clean fuel - kerosene, No. 1 home heating fuel or diesel. Clean or replace fuel filter every 100 hours of operation. Avoid water contaminated fuel as it will seize up the fuel pump. Desoot coils monthly or use an additive if diesel is being used.
- Check to see that water pump is properly lubricated.
- Follow winterizing procedure to prevent freeze damage to pump and coils.
- Always flush detergents from system after use.
- If water is known to be high in mineral content, use a water softener on your water system or use a *LANDA* recognized coil cleaning detergent.
- Do not allow acidic, caustic or abrasive fluids to be pumped through the system.
- Always use high grade quality *LANDA* cleaning detergents.
- Never run pump dry for extended periods of time.
- Periodically descale coils per instructions.
- If machine is operated with smoky or eye-burning exhaust, coils will soot up and prevent water from reaching maximum operating temperature. See section on burner adjustments.

Maintenance And Service

Pump Lubrication

Use only *LANDA* SAE 10W-40 weight, non-foaming oil. Change oil after first 50 hours of use. Thereafter, change oil every year or at 500 hour intervals. Oil level should be checked through use of dipstick found on top of pump or red dot visible through oil gauge window. Oil should be maintained at that level

Fuel

Use clean (not contaminated with water and debris) kerosene, No. 1 home heating fuel or diesel. Drain fuel tank and replace fuel filter every 100 hours of operation.

Electrode Setting

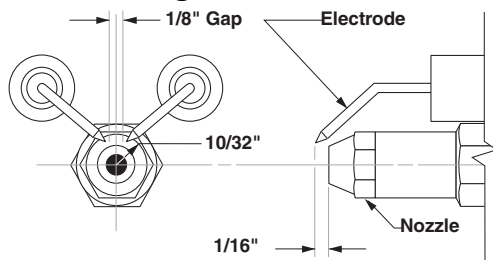

Ignition Circuit

Periodically inspect wires, spring contact and electrodes for condition, security and proper spacing. Transformer test: **CAUTION:** 10,000 volts — use defect free insulated screwdriver and keep fingers off blade! Lay blade across one contact: OK if arc will span 1/2" between end of blade and other contact (see illustration below).

Transformer Check

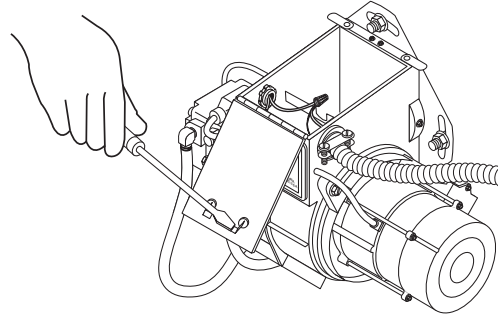

Fuel Control System

These machines utilize a fuel solenoid valve located on the fuel pump to control the flow of fuel to the combustion chamber. This solenoid, which is normally closed, is activated by the flow switch. When an operator releases the trigger on the spray gun, the unloader goes into a by-pass mode, thus stopping electrical current to the fuel solenoid coil. With the solenoid closed, the fuel supply to the combustion chamber ceases. Periodic inspection to insure that the fuel solenoid valve functions properly is recommended. This can be done by operating the machine and checking to see that when the spray gun is in the off position, the burner is not firing.

Fuel Pressure Adjustment

To adjust fuel pressure, turn the adjusting screw clockwise to increase, counterclockwise to decrease. Do not exceed 200 PSI. **NOTE:** When changing fuel pump, a bypass plug must be installed in return line port or fuel pump will not prime.

Burner Nozzle

Keep tip free of surface deposits by wiping with clean, solvent-saturated cloth, being careful not to plug or enlarge nozzle. For maximum efficiency, replace nozzle each season.

Wayne Oil Burner

Burner Air Adjustment: The oil burner on this machine is preset for operation at altitudes below 500 feet. If operated at higher altitudes, it may be necessary to adjust the air band for a #1 or #2 smoke spot on the Bacharach scale.

To adjust, start machine and turn burner ON. Loosen two locking screws found on the air band and close air band until black smoke appears from burner exhaust vent. Note air band position. Next, slowly open the air band until white smoke just starts to appear. Turn air band halfway back to the previously noted position. Tighten locking screws.

For higher altitudes, the air band opening may need to be increased; for lower altitude, the air band may need to be decreased.

For higher humidity, the air band opening may need to be increased; for lower relative humidity, the air band may need to be decreased.

For higher ambient temperatures the air band opening may need to be increased; for lower ambient temperatures, the air band opening may need to be decreased.

Adjust to your operating location's environment as needed for best smoke spot and performance compliant with local, state, and federal regulations.

Fuel Pressure Adjustment

To adjust fuel pressure, First install a pressure gage into the port just after the pump fuel exit. Turn the adjusting screw (located at the regulator port) clockwise to increase, and counterclockwise to decrease. Do not exceed 200 psi or lower the pressure below 130 PSI, when checked at the post-pump pressure port.

The fuel pressure may need to be adjusted due to altitude. For every 500 ft altitude above sea level, the boiling point of water goes down 1 °F. At high altitude environments, this boiling point change may require the heat input to be lowered so the water input does not turn to steam earlier than at the factory settings and activate the pressure sensors and pressure relief equipment when the unit is operated and much higher altitudes from factory settings or local dealer site settings. Check with your dealer before making local site fuel pressure adjustments.

Also, as ambient temperature changes seasonally, the fuel temperature in the feed tank and air temperature inlet can impact fuel flow. In more extreme temperatures, this local-site adjustment may also require

different fuel nozzles for fuel inlet temperatures that are at seasonal extremes (higher or lower) in locations where the temperature changes are beyond moderate temperatures of between 40°F and 90°F. Colder temperatures will make for a thicker flow and less fine a fuel spray while hotter temperatures will make for a thinner flow a more fine spray with the same nozzle. Consider alternate nozzle configurations from the baseline factory-supplied nozzle for operating in such temperature extremes if performance is not meeting needs with air band and fuel pressure settings alone.

NOTE: When changing fuel pump, a by-pass plug must be installed in return line port or fuel pump will not prime.

Burner Air Adjustment

The oil burner on this machine is preset for operation at altitudes below 500 feet. If operated at higher altitudes, it may be necessary to adjust the air band for a #1 or #2 smoke spot on the Bacharach scale.

To adjust, start machine and turn burner ON. Loosen two locking screws found on the air band and close air band until black smoke appears from burner exhaust vent. Note air band position. Next, slowly open the air band until white smoke just starts to appear. Turn air band halfway back to the previously noted position. Tighten locking screws.

For higher altitudes, the air band opening may need to be increased; for lower altitude, the air band may need to be decreased.

For higher humidity, the air band opening may need to be increased; for lower relative humidity, the air band may need to be decreased.

For higher ambient temperatures the air band opening may need to be increased; for lower ambient temperatures, the air band opening may need to be decreased.

Adjust to your operating location's environment as needed for best smoke spot and performance compliant with local, state, and federal regulations.

CAUTION: If white smoke appears from burner exhaust vent during start-up or operation, discontinue use and readjust air bands.

ATTENTION: Si de la fumée blanche s'échappe de l'évacuation du brûleur pendant le démarrage ou le fonctionnement, cesser d'utiliser et réajuster les bandes d'air.

NOTE: If a flue is installed, have a professional serviceman adjust your burner for a #1 or #2 smoke spot on the Bacharach scale.

Maintenance

Cleaning of Coils

In alkaline water areas lime deposits can accumulate rapidly inside the coil pipes. This growth is increased by the extreme heat buildup in the coil. In areas where alkaline water is an extreme problem, periodic use of Landa Coil Descaler (Part # 8.914-296.0) will remove lime and other deposits before coil becomes plugged.

Periodic descaling of the heating coil is recommended so please consult your local Landa Dealer for instructions.

Spray Nozzles

Each machine is equipped with four spray nozzles. Different spray nozzles are calibrated for each machine depending on the flow and pressure of that particular model. Spray nozzles vary in bore size and angle of spray. Popular spray angles are 15°, 25° and 40°. When ordering, please specify size and angle of nozzle. Nozzle size for each machine is located on the serial plate.

Unloader Valves

Unloader valves are preset and tested at the factory before shipping. Tampering with the factory setting may cause personal injury and/or property damage, and will void the manufacturer's warranty. (Consult your local LANDA Dealer for the correct procedures.)

Winterizing Procedure

Damage due to freezing is not covered by warranty. Adhere to the following cold weather procedures whenever the washer must be stored or operated outdoors under freezing conditions.

During the winter months, when temperatures drop below 32° F, protecting your machine against freezing is necessary. Siphoning a small amount of antifreeze into the system is recommended. Pouring a 50/50 mix of antifreeze and water into the float tank and then siphon 100% antifreeze through the detergent line with the pump on. If compressed air is available, an air fitting can be screwed into the float tank strainer fitting and, by injecting compressed air, all water will be blown out of the system.

Low Pressure Diagnosis

Refer to the low pressure section of the troubleshooting guide. If, by referring to the guide, the trouble is found to be either the unloader or pump, your next step is to determine which is the problem. This can be done by eliminating the unloader from the system and attaching the discharge hose directly to the pump. If high pressure is present, then the unloader needs repairing or replacing.

CAUTION: When using this procedure to test components, keep spray gun open at all times.

ATTENTION: Lorsque cette procédure est utilisée pour tester les composants, garder le pistolet pulvérisateur ouvert en tout temps.

Coil Removal

Removal of the coil because of freeze breakage or to clean soot from it, can be done quickly and easily.

1. Disconnect hose from pump/unloader to inlet side of coil.
2. Disconnect the electrical connections to the thermostat or remove thermostat sensor.
3. Remove all the fittings from the discharge and inlet side of the coil.
4. Remove burner assembly from combustion chamber.
5. Remove 3 - 3/8" bolts from either side of coil and tank assembly (these bolts are used to fasten tank and handles to chassis).
6. Remove the two 3/8" nuts which are underneath the bottom wrap (to keep the coil from moving).
7. Remove tank top wrap exposing insulation and coil. Carefully bend insulation tabs at exhaust stack.
8. Carefully fold back insulation and remove the coil.
9. Replace or repair any insulation found to be torn or broken.
10. Reinstall new or cleaned coil by reversing steps 8 through 1.

Temperature and Pressure Relief Valve

(Pump Protector)

Machines with spray gun control offer the operator the convenience of stopping and starting the flow of water at the end of the discharge hose. When the spray gun stops the flow of water, the unloader valve, back at the machine, opens and recycles the cold water back to the inlet side of the pump. Recycling for longer than five minutes causes the cold water within the pump to heat up. To avoid damage to the pump, a temperature and pressure relief valve is installed next to the inlet side of the pump that will open in the event the water temperature exceeds 140° F. Therefore, while operating the machine, do not leave the spray gun closed for an extended period of time.

High Limit Hot Water Thermostat

For safety, PHW machines are equipped with adjustable thermostats. If the temperature of the water should exceed its operating temperature, the adjustable thermostat will turn the burner off until the water cools, then it will automatically reset itself.

Rupture Disk

If pressure from pump or thermal expansion should exceed safe limits, the rupture disk will burst, allowing high pressure to be discharged through hose to ground. When the disk ruptures, it will need to be replaced.

Optional Time Delay Shutdown Operation

Once the spray gun trigger is released, the shutdown timer becomes activated. The machine will continue to run in by-pass mode until the timer reaches its preset time, 3 minutes. When that time is reached, the machine shuts down. To restart, push the pump switch forward.

Optional Auto Start/stop Timer Operation

Once the pump switch is turned on, simply triggering the spray gun is all it takes to start the machine. Once the trigger is released the timer will let the machine bypass water for 15 seconds. It also starts an internal 5 to 60 minute lockout timer. This feature is totally adjustable by the operator by adjusting the knob at the top of the timer. We recommend setting the timer for 15 minutes. To reset the lockout feature, operator must trigger the spray for 10 full seconds.

Maintenance

Preventative Maintenance

This pressure washer was produced with the best available materials and quality craftsmanship. However, you as the owner have certain responsibilities for the correct care of the equipment. Attention to regular preventative maintenance procedures will assist in preserving the performance of your equipment. Contact your dealer for maintenance. Regular preventative maintenance will add many hours to the life of your pressure washer. Perform maintenance more often under severe conditions.

Maintenance Schedule		
Replace Fuel Lines		Annually
Pump Oil 10W-40 Non-Foaming	Inspect	Daily inspect the oil level
	Change	After first 50 hours, then every 500 hours or annually
Clean Burner Filter		Monthly (More often if fuel quality is poor)
Remove Burner Soot		Annually
Burner Adjustment/Cleaning		Annually
Descale Coil		Annually - (more often if required)
Replace High Pressure Nozzle		Every 6 months
Replace Quick Connects		Annually
Clean Water Screen/Filter		Weekly
Clean Float/Supply Tank		Every 6 months
Replace HP Hose		Annually if there is any sign of wear
Grease Motor		Every 10,000 hours
Replace Burner Nozzle		Annually

Maintenance

Troubleshooting

PROBLEM	POSSIBLE CAUSE	SOLUTION
LOW OPERATING PRESSURE	Faulty pressure gauge	Test with 2nd gauge. If bad, install new gauge.
	Insufficient water supply	Use larger garden hose; clean water filter at inlet. Clean screen inside float tank.
	Old, worn or incorrect nozzle	Match nozzle number to machine and/or replace with new nozzle.
	Belt slippage	Tighten or replace; use correct belt.
	Plumbing or hose leak	Check plumbing system for leaks. Retape leaks with teflon tape.
	Faulty or mis-adjusted unloader valve	Adjust unloader for proper pressure. Install repair kit when needed. Test PSI with unloader removed, taking pressure directly off the pump.
	Worn packing in pump	Install new packing kit.
	Fouled or dirty inlet or discharge valves in pump	Clean inlet and discharge valves.
	Worn inlet or discharge valves	Replace with valve kit.
	Obstruction in spray nozzle	Remove obstruction.
	Low power supply	Check voltage of building and compare with requirements. Obtain a different power source.
	Detergent metering valve left open sucking air, or faulty metering valve	Close and/or replace metering valve.
BURNER WILL NOT LIGHT	Little or no fuel	Fill tank with fuel.
	Improper fuel or water in fuel	Drain fuel tank and fill with proper fuel.
	Plugged fuel filter	Replace as needed.
	Mis-adjusted burner air bands	Readjust air bands for clean burn.
	Little or no fuel pressure from fuel pump	Increase fuel pressure to specifications and/or replace fuel pump.
	Faulty burner transformer	Test transformer for proper arc between contacts. Replace as needed.
	Disconnected or short in electrical wiring	All wire contacts should be clean and tight. No breaks in wire.
	Burner motor thermal protector tripped	If tripped, check voltage, connections and extensions for cause. Check fuel pump shaft rotation for binding causing motor to overheat.
	Flex-Coupling slipping on fuel pump shaft or burner motor shaft	Replace if needed.
	ON-OFF switch defective	Check burner switch for continuity.

PROBLEM	POSSIBLE CAUSE	SOLUTION
BURNER WILL NOT LIGHT (CONTINUED)	Heavy sooting on coil and burner can cause interruption of air flow and shorting of electrodes.	Clean as required.
	Improper electrode setting	Clean and set according to diagram in Operator's Manual.
	Fuel not reaching combustion chamber	Check fuel pump for proper flow. Check solenoid flow switch on machines with spray gun control for proper on-off fuel flow control.
	Clogged burner nozzle	Replace.
	Water not flowing through flow switch	Open spray gun to allow water to flow.
	Flow switch malfunction	Remove reed and test for continuity. Replace if needed.
	Fuel solenoid malfunction	Replace if needed.
UNIT SMOKES WHILE BURNER IS RUNNING OR SMOKES AT COLD-START WHEN BURNER IS OFF ADJUST FOR LOCAL ALTITUDE, HUMIDITY, AND AMBIENT AIR TEMPERATURE.	Improper fuel or water in fuel	Drain tank and replace contaminated fuel.
	Improper air adjustment	Readjust air bands on burner assembly.
	Low fuel pressure	Adjust higher.
	Air leaks in fuel lines	Check fuel lines for leaks or air bubbles. Tighten or replace as needed.
	Plugged or dirty burner nozzle	Replace.
	Faulty burner nozzle spray pattern	Replace nozzle.
	Heavy accumulation of soot on coils and burner assembly	Remove coils and burner assembly. Clean thoroughly.
	Misaligned electrode	Realign electrodes.
	Obstruction in smoke stack	Check for insulation blockage or other foreign objects.
LOW WATER TEMPERATURE	Improper fuel or water in fuel	Drain fuel tank and replace with proper fuel.
	Low fuel pressure	Increase fuel pressure.
	Weak fuel pump	Check fuel pump pressure. Replace pump if needed.
	Fuel filter partially clogged	Replace if needed.
	Soot build-up on coils	Clean coils with soot remover.
	Lime build-up in coils	Clean inside of coils with coil clean.
	Improper burner nozzle	See tank assembly parts list for correct nozzle.

Maintenance

PROBLEM	POSSIBLE CAUSE	SOLUTION
WATER TEMPERATURE TOO HOT	Incoming water to machine warm or hot	Lower incoming water temperature.
	Fuel pump pressure too high	Readjust fuel pressure.
	Fuel pump defective	Replace fuel pump.
	Detergent line sucking air	Tighten all clamps. Check detergent line for holes.
	Defective high limit switch	Replace.
	Incorrect fuel nozzle size	See exploded view parts list for proper size.
	Insufficient water supplied	Check GPM to machine.
	Restricted water flow	Check nozzle for obstruction and proper size.
PUMP MOTOR STOPS AFTER A FEW MINUTES OF OPERATION OR STARTS SLOW	Insufficient voltage	Use heavier drop cord and check voltage at receptacle. Check name plate for amperage draw.
	Plugged nozzle	Remove and clean nozzle. Turn on water pump and flush lines, replace nozzle.
	Wrong spray nozzle	See serial plate for minimum nozzle size.
	Automatic overload switch tripped	Allow motor to cool - switch will automatically reset.
	Motor wet	Allow to dry.
	Short in electrical wiring	Wire contacts should be clean and tight. No breaks in wires.
	Coil liming up causing excessive pressure	See section on Preventative Maintenance.
	Water pump low or out of oil causing the pump to bind up	Fill to correct level.
RELIEF VALVE LEAKS OR SPRAYS OUT WATER	Spray nozzle plugged	Remove nozzle and clean out obstruction.
	Mis-adjusted or defective relief valve	Adjust or replace as needed.
	Scale or dirt plugging inside of coils	See "Preventative Maintenance Cleaning of Coils."
DETERGENT NOT DRAWING	Air leak	Tighten all clamps. Check detergent lines for holes.
	Detergent metering valve packing not tight or packing worn	Tighten nut. Replace valve or packing.
	Filter screen on detergent suction hose plugged	Clean or replace.
	Dried up detergent plugging metering valve or injector	Clean and flush.
	Restrictor in float tank missing	Install restrictor.
	High viscosity of detergent	Dilute detergent to specifications. Read detergent label.

PROBLEM	POSSIBLE CAUSE	SOLUTION
MACHINE WILL NOT DRAW UP DETERGENT	Clamps holding detergent lines are loose	Tighten clamps.
	Hole in detergent line(s)	Repair hole.
	Strainer basket plugged	Remove and clean.
BURNER MOTOR WILL NOT RUN	Overload protector tripped	Push reset button.
	Fuel pump seized	Replace fuel pump.
	Burner fan loose or misaligned	Position correctly and tighten set screw.
	Defective control switch	Replace switch.
	Loose wire	Check and replace or tighten wiring.
	Defective burner motor	Replace motor.
EXCESSIVE VIBRATION IN DELIVERY LINE	Irregular functioning of check valves, metering valves	Check and replace if necessary.
TEMPERATURE RELIEF VALVE LEAKS WATER (PUMP PROTECTOR)	Spray gun in OFF position with machine operating for an extended period of time	Open spray gun to cool circulating water.
	Relief valve defective	Replace valve.
	Particle next to poppet	Remove internal parts and clean.
BURNER STAYS ON WHEN SPRAY GUN IS IN OFF POSITION	Fuel pump pressure too high	Readjust fuel pressure.
	Pressure switch defective	Check for proper operation, replace if necessary.
	Fuel solenoid defective	Replace fuel solenoid.
PUMP RUNNING NORMALLY BUT PRESSURE LOW	Pump sucking air	Check water supply and possibility of air seepage.
	Valves sticking	Check and clean or replace if necessary.
	Unloader valve seat faulty	Check and replace if necessary.
	Nozzle incorrectly sized	See serial plate for minimum nozzle size.
	Worn piston packing	Check and replace if necessary.
PUMP NOISY	Air in suction line	Check water supply and connections on suction line.
	Broken or weak inlet or discharge valve springs	Check and replace if necessary.
	Excessive temperature of liquid	Reduce to below 60° C (140° F).
	Foreign matter in valves	Check and clean if necessary.
	Worn bearings	Check and replace if necessary.

Maintenance

PROBLEM	POSSIBLE CAUSE	SOLUTION
PRESENCE OF WATER IN OIL	Oil seal worn	Check and replace if necessary.
	High humidity in air	Check and change oil twice as often.
	Piston packing worn	Check and replace if necessary.
WATER DRIPPING FROM UNDER PUMP	Piston packing worn	Check and replace if necessary.
	O.R. plunger retainer worn	Check and replace if necessary.
	Cracked ceramics	Check and replace if necessary.
OIL DRIPPING	Oil seal worn	Check and replace if necessary.
	Cracked manifold	Check and replace if necessary.
WON'T START	Faulty timer	By-pass timer by joining wires 15 & 16 on timer together. If it starts, replace timer.
WON'T TIMEOUT	Faulty reed switch	Check for continuity. Replace if necessary.
	Faulty relay or base	Check relay cube or relay base for proper continuity. Replace if necessary.

PROBLEM	POSSIBLE CAUSE	SOLUTION
SYSTEM WILL NOT COME UP TO FULL DESIGNATED PRESSURE	Spray nozzle worn or nozzle orifice is too large in relation to pump flow rate	See serial plate for correct nozzle size.
	Adjusted improperly	Readjust unloader with pressure gauge.
	Bypass valve (within unloader) is obstructed or leaking	Remove and clean bypass cartridge or replace.
	Flow rate of pump inadequate	Assure designated flow rate of pump is adequate in relation to spray nozzle size.
PRESSURE SPIKES IN DISCHARGE LINE DURING BYPASS MODE	Pressure adjustment too tight	Call your local dealer.
	Restricted bypass line	Bypass line should be 1/2" inside diameter (I.D.), 12" long and of low pressure flexible hose.
	Flow rate higher than 8 gpm	Unloader flow rate is 7.8 gpm maximum.
UNLOADER CYCLES WHILE IN BYPASS MODE	External leak on unloader or in downstream fittings	Inspect all high pressure lines (including spray gun and hose) for any signs of leakage and repair as necessary.
	Discharge valve (within the unloader) damaged, obstructed or worn	Inspect and replace as necessary.
	Weep gun is being used	The unloader is not designed for use with a weep gun.

LANDA[®]

8.917-417.0 • Printed in U.S.A.