

Trailer HDS Series



Operator's Manual

Pressure Washer

MODEL: HDS 3.5/40 GE MT
1.103-844.0

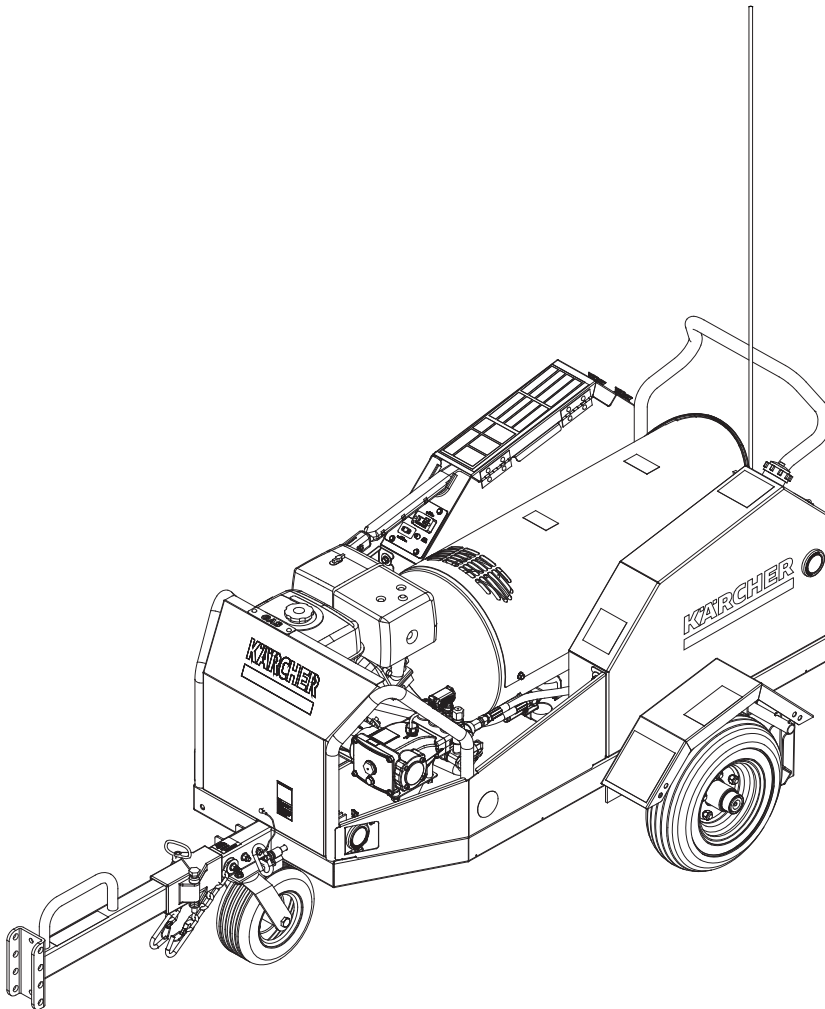

**SHOP
PRESSURE
WASHER
PARTS**

shoppressurewasherparts.com

888.269.0172

WARNING:

This product and accessories may contain a chemical known to the State of California to cause cancer and birth defects or other reproductive harm.



For more information about this regulation: www.P65Warnings.ca.gov



9.807-942-0-B

12/11/17

Model Number: _____
Serial Number: _____
Date of Purchase: _____
The model and serial numbers will be found on a decal attached to the pressure washer. Record both serial number and date of purchase.

PATENT PENDING

Introduction

Thank you for purchasing this Pressure Washer. We reserve the right to make changes at any time without incurring any obligation.

Owner/User Responsibility:

The owner and/or user must have an understanding of the manufacturer's operating instructions and warnings before using this pressure washer. Warning information should be emphasized and understood. If the operator is not fluent in English, the manufacturer's instructions and warnings shall be read to and discussed with the operator in the operator's native language by the purchaser/owner, making sure that the operator comprehends its contents. Owner and/or user must study and maintain for future reference the manufacturers' instructions.

Save These Instructions

This manual should be considered a permanent part of the machine and should remain with it if machine is resold. When ordering parts, please specify model and serial number. Use only identical replacement parts. This machine is to be used only by trained operators.

Notice

This trailer is equipped to meet applicable U.S. Federal safety standards. Check local and state requirements regarding brakes and any additional equipment that may be required. Any modifications or additions including load equalizing hitches, without written factory consent: usage in an abnormal manner including overloading voids all manufacturers' warranties and liability.

WARNING: This Owner's Manual contains safety information and instructions for your trailer. You must read this manual before loading or towing your trailer. You must follow all safety precautions and instructions.

Machine Data Label	2	Posi-lube Lubrication Procedure	27
Table of Contents	3	Troubleshooting	28
 		Maintenance Schedule	30
<i>Safety</i>		Trailer Maintenance	31
Important Safety Information	4	Pump And Engine Oil Change Record	31
Important Trailer Safety Information	7		
Tire Safety	7		
Maintaining Proper Tire Pressure	8		
Never Tow the Trailer Before Checking	8		
Tow Vehicles	8		
Safety Chains	10		
Load-Carrying Capacity	10		
Tongue Weight	11		
Caster Operations	12		
Trailer Brake Operations	13		
What to Check And How To Check	14		
Tire Pressure	14		
Wheels	14		
Wheel Lugs	14		
Ball Coupler Hitches	14		
Tires	14		
<i>Operations</i>			
Trailer Component Identification	15		
Accessory Assembly Instructions	16		
Assembly Instructions	17		
Installation	18		
Operating Instructions	19		
Detergents & General			
Operating Techniques	20		
Shutting Down And			
Clean-Up	21		
Storage	22		
<i>Maintenance</i>			
Preventative Maintenance	23		
Maintenance And Service	23		
Unloader Valves	23		
Winterizing Procedure	23		
High Limit Hot Water Thermostat	23		
Pumps	23		
Cleaning of Coils	23		
Fuel	24		
Burner Nozzle	24		
Oil Burner	24		
Electrode Setting	25		
KNA Burner Air Adjustment	25		
Fuel Pressure Adjustment	25		
Removal of Soot and Heating Coil	25		
Hub Inspection Removal-			
Replacement And Adjustments	26		
Torque Wrench Method	27		

Important Safety Information

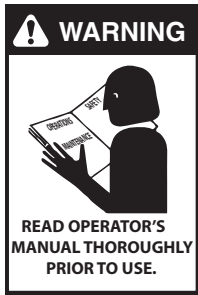

WARNING: To reduce the risk of injury, read operating instructions carefully before using.

1. Read the owner's manual thoroughly. Failure to follow instructions could cause malfunction of the machine and result in death, serious bodily injury and/or property damage.

2. Know how to stop the machine and bleed pressure quickly. Be thoroughly familiar with the controls.

3. Stay alert — watch what you are doing.



DANGER: Keep wand, hose, and water spray away from electric wiring or fatal electric shock may result.

4. To protect the operator from electrical shock, the machine must be electrically grounded.



WARNING: Flammable liquids can create fumes which can ignite, causing property damage or severe injury.

WARNING: Risk of explosion — Operate only where open flame or torch is permitted.

5. In oil burning models, use only kerosene, No. 1 home heating fuel, or diesel. If diesel is used,

add a soot remover to every tankful.



WARNING: Risk of fire — Do not add fuel when the product is operating or still hot.

WARNING: Do not use gasoline crankcase draining or oil containing gasoline, solvents or alcohol. Doing so will result in fire and/or explosion.

6. Operate only in locations where combustible dusts and flammable gases or vapors are not present. Do not store or use gasoline near this machine.

7. Do not allow acids, caustic or abrasive fluids to pass through the pump.

8. Never run pump dry or leave spray gun closed longer than 1-2 minutes.

9. Keep operating area clear of all persons.



WARNING: High pressure spray can cause paint chips or other particles to become airborne and fly at high speeds. To avoid personal injury, eye, hand and foot safety devices must be worn.

10. Always wear properly rated eye protection such as safety goggles or face shield while spraying.

(Safety glasses do not provide full protection.)



WARNING: This machine exceeds 85 dB. Appropriate ear protection must be worn.

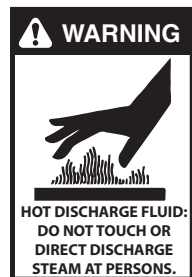

WARNING: Hot discharge fluid. Do not touch or direct discharge stream at persons or animals.

WARNING: This machine produces hot water and must have insulated components attached to protect the operator.



WARNING: Risk of injury. Hot surfaces can cause burns. Use only designated gripping areas of spray gun and wand. Do not place hands or feet on non-insulated areas of the pressure washer.

11. To reduce the risk of injury, close supervision is necessary when a machine is used near children. Do not allow children to operate the pressure washer. **This machine must be attended during operation.**



WARNING: Grip cleaning wand securely with both hands before starting. Failure to do this could result in injury from a whipping wand.

12. Never make adjustments on machine while in operation.

13. Be certain all quick coupler fittings are secured before using pressure washer.



WARNING: High pressure developed by these machines will cause personal injury or equipment damage. Keep clear of nozzle. Use caution when operating. Do not direct discharge stream at people or animals, or severe injury or death will result.



WARNING: Protect machine from freezing.

14. To keep machine in best operating conditions, it is important you protect machine from freezing. Failure to protect machine from freezing could cause malfunction of the machine and result in death, serious bodily injury, and/or property damage.

Follow storage instructions specified in this manual.

15. Inlet water must be clean fresh water and no hotter than 90°F.



DANGER: Risk of asphyxiation. Use this product only in a well ventilated area.

16. Avoid operating machines in small areas or near exhaust fans. Adequate oxygen is needed for combustion or dangerous carbon monoxide will result.

17. Manufacturer will not be liable for any changes made to our

standard machines or any components not purchased from us.

18. The best insurance against an accident is precaution and knowledge of the machine.



WARNING: Be extremely careful when using a ladder, scaffolding or any other relatively unstable location. The cleaning area should have adequate slopes and drainage to reduce the possibility of a fall due to slippery surfaces.

19. Do not overreach or stand on unstable support. Keep good footing and balance at all times.

20. Do not operate this machine when fatigued or under the influence of alcohol, prescription medications, or drugs.



Follow the maintenance instructions specified in the manual.

Reporting Safety Defects

If you believe that your trailer has a defect which could cause a crash or could cause injury or death, you should immediately inform the National Highway Traffic Safety Administration (NHTSA) in addition to notifying Kärcher.

If NHTSA receives similar complaints, it may open an investigation, and if it finds that a safety defect exists in a group of trailers, it may order a recall and remedy campaign. However, NHTSA cannot become involved in individual problems between you, your dealer or Kärcher.

To contact NHTSA, you may either call the Auto Safety Hotline toll-free at 1-888-327-4236 (TTY: 1-800-424-9153) or write to:

NHTSA
1200 New Jersey Avenue, SE
West building
Washington, DC 20590

You can also obtain other information about motor vehicle safety from, <http://www.safercar.gov>.

Checklist

Before Every Trip:

- Tire pressure and tire condition
- Wheel lugs*
- Bearing lube and tightness
- Hitch
- Safety chains
- 12V running lights
- Distribution and security
- Caster up in travel position

* Check lug nuts for tightness before initial trip, at 10 miles, 25 miles and 50 miles. Recheck every 3 months or 3000 miles.

NOTE: Checking all of the above steps before every trip is key for safety.

Referencing the Utility Trailer in this Manual

All references to the trailer or component parts to either left or right are made with the assumption that you are standing behind the trailer facing forward. Your left hand or right hand is the equivalent on the trailer.

Tire Safety

The most common cause of trailer tire failure is under-inflation. Therefore, it is important that you always maintain the specified air pressure as indicated by the tire manufacturer on the tire's side-walls. This information can also be found on the tire label or the air pressure molded on the tire side-wall.

The most important things you can do to maintaining proper tire pressure are observe all tire and trailer maximum carrying capacities, avoid road hazards, and inspect the tires for cuts, slashes and other irregularities. These practices, along with other care and maintenance, can improve handling, help protect you and others from avoidable breakdowns and accidents, improve fuel economy, and increase the life of your tires.

Make tire safety a regular part of your trailer maintenance routine. The time you spend is minimal compared to the amount of time, inconvenience, and potential safety hazards that can occur from a flat tire or failure.

Basic Tire Maintenance

Properly maintained tires improve the load-carrying capability of your trailer. You can help avoid flat tires and tire failures by maintaining proper tire pressure, observing tire and trailer capacity limits, avoiding road hazards, and inspecting your tires regularly.

Identifying Your Recommended Tire Pressure and Maximum Load Carrying Capacity for Your Trailer

Both the tire placard and the VIN label are permanently attached on top of the frame of your trailer and have the required information printed on them. They also list the maximum load that can be placed on the trailer without exceeding the load limits of the tires or the trailers other components. These labels indicate the manufacturer's information including:

Recommended tire size.

- Recommended tire inflation pressure.

- The maximum weight the trailer is designed to carry.
- Gross vehicle weight rating of the trailer.
- Gross axle weight rating of the trailer.

Understanding Tire Pressure and Load Limits

Tire inflation pressure is the level of air in the tire that provides it with the load-carrying capacity and affects the overall performance of the trailer. The tire inflation pressure is a number that indicates the amount of air pressure that is inside the tire. It is measured in pounds per square inch (PSI). The tire must be inflated to the air pressure as designated on the labels. Also listed on the labels is the air pressure in kilo Pascals (kPa), which is a metric measurement. Tire manufacturers determine the air pressure to maximize the amount of weight the tires can safely carry. The proper tire pressure for your trailer tires is referred to as the "recommended cold inflation pressure." It is difficult to obtain the recommended tire pressure if your tires are not cold when the reading is taken because the air will expand when it is warmed by towing down the road, thus increasing the air pressure inside. If air is added to a tire that is low the air pressure should never exceed the recommended pressure.

It is important to check your trailer's tire pressure at least once a month for the following reasons:

Most tires will naturally lose air over time.

Tires can lose air suddenly if driven over an object that punctures or cuts the tire. Sometimes a sharp blow from a pothole or curb can knock the tire loose from the rim causing immediate deflation.

Maintaining Proper Tire Pressure

Locate the recommended tire pressure on the trailer's tire information placard or owner's manual.

Record the tire pressure of all tires. If the tire pressure is too high in any of the tires, slowly release air by gently pressing on the tire valve stem with the edge of your tire gauge until you get the correct pressure.

If the tire pressure is too low, note the difference between the measured tire pressure and the correct tire pressure. These "missing" pounds of pressure are what you will need to add.

Add the missing pounds of air pressure to each tire that is under inflated.

Check all tires to make sure they have the same air pressure.

If you have been towing your trailer and think that a tire is under inflated, fill it to the recommended cold inflation pressure indicated on your trailer's tire label placard or the VIN label. You can also check the sidewall of the tire for a correct tire inflation pressure. Your tire will have a slightly lower air pressure because the tire is warm when you are inflating it, but it will be much better than to continue to tow it with the under inflation it may have had. Once the trailer has been parked long enough to allow the tires to cool down, recheck the tire pressure and add additional air to return the tire pressure to the recommended level.

Tire Size

To maintain the trailer's carrying capacity and safety, purchase only the same size tires as what were originally supplied on the trailer.

Safety Tips

Slow down if you have to go over a pothole or other object in road.

Do not run over curbs and try not to strike the curb when parking.

For a free brochure visit:

www.nhtsa.dot.gov

IMPORTANT: Before towing this trailer be sure to read the instructions and warnings supplied in this manual. Also read the information supplied with your tow vehicle so you know and understand it's limitations.

Never Tow the Trailer Before Checking

- Coupler and latch assembly show no signs of wear or damage.
- Coupler hitch and hitch ball are of the same size.
- Coupler and safety chains are safely secured to the hitch.
- Check all fasteners for proper tightness.
- Load is securely tied down to the trailer.
- Wheel lug nuts are properly tightened to the right torque.
- Wheel bearings are properly adjusted and maintained.
- Load is within the maximum load carrying capacity of trailer.
- Tires are properly inflated and are road worthy.
- All trailer lighting is working properly.

IMPORTANT: The load must be distributed equally on the bed of the trailer if possible. Heavy, concentrated loads may cause damage or possible failure of the trailer.

WARNING: Loads placed on the trailer must be securely tied to the trailer. Always use appropriate tie downs designed to restrict loads from moving when properly attached. Failure to do so will allow shifting of the load causing potential trailer failure and/or loss of the load and personal injury.

This trailer is equipped to meet all applicable federal safety standards in effect the day of manufacture. Check local and state requirements regarding any additional equipment that may be required.

The addition of optional equipment to your trailer may increase the total weight of your trailer package to where it now exceeds the maximum load carrying capacity of the trailer.

Tow Vehicles

WARNING: Serious injury or property damage can result if the total weight of your loaded trailer exceeds the capacity of the hitch and/or your tow vehicle.

It is very important that you know and understand the towing capabilities of your tow vehicle. This is especially true with the braking abilities of the tow vehicle. You should check with your authorized dealer to see what the capabilities are for the total towing load and the maximum allowable tongue weight for the vehicle you plan on using for towing.

It is also important that the lighting system in the tow vehicle has sufficient capacity support the additional load the trailer lighting will add to the system. A heavy duty flasher may be required to make your turn signals function properly.

Trailer Ball & Couplers

WARNING: Failure to properly engage the hitch ball in the coupler ball socket and securely lock the coupler latch mechanism can cause the trailer to become detached from the tow vehicle while traveling, which may cause serious injury or property damage.

Ball diameter for which rating (GVWR) shall not exceed the gross trailer weight marked on the trailer coupler.

The hitch balls have the rated load they are capable of towing stamped into the top of the ball.

Make sure the ball that you use to tow your trailer has the same capacity rating as the coupler.

Do not use a different size ball than the size the coupler is designed to use.

Class	Coupler	Ball Diameter
II	3,500# GVWR	2"
III	5,000# GVWR	2"
IV	8,000# GVWR	2"

Hitch Coupler Troubleshooting

If the coupler becomes damaged it must be repaired or replaced before towing. When the coupler is placed on the ball, the latch should close firmly. Keep the latch mechanism lightly oiled and clean. Items to check for are as follows:

1. Latch does not grasp ball securely:
 - Check the ball size. Make sure the ball and coupler are the same size.
2. Latch does not snap into full latch position:
 - Check adjustment. Latch mechanism may be too tight.
 - Check to see that the coupler housing has not been damaged, keeping the ball hitch from fitting completely into the housing as designed.
3. Keep the tongue blocked up when not in use so the coupler and mechanism are not in the ground being exposed to dirt and moisture.

4. Apply a small amount of an automotive grease to the ball before hitching coupler to prevent wear of the two parts during towing.
5. Make sure the latch safety pin is in position before towing.

Coupler & Ball Engagement

If the coupler and towing ball resist attempts to make engagement, do not force latch assembly. Instead, check the ball diameter to verify that it conforms to Society of Automotive Engineers (SAE) specifications. Standard two-inch diameter ball should be within the limits of 2.000-inches to 1.970-inches. Balls larger than 2.000- inches will not readily fit the coupler. A two-piece coupler ball is not recommended.

If the coupler becomes damaged it must be repaired or replaced before towing. When the coupler is placed on the ball, the latch should close firmly. Keep the latch mechanism lightly oiled and clean.

Improper engagement of the coupler and ball can cause damage if the vehicles separate in transit, thus, caution must be exercised to insure a secure hook-up. Lower the coupler onto the ball with the coupler latch in the vertical position. Continue to lower the trailer tongue until the jack clears the ground, then flip the coupler latch to its locked (horizontal) position. At this point visually observe that the ball is fully engaged in the ball hitch. An even better check to make sure the two are fully engaged is to raise the tongue of the trailer again using the jack. Raise until the ball hitch connection starts to raise the rear of the tow vehicle. If the connection was not properly made, the ball and socket will separate as the tongue of the trailer is raised.

Safety Chains

Listed in the chart below are the different class sizes of safety chains and the rated load each chain must be capable of withstanding.

TRAILER CLASS	TRAILER WEIGHT GVWR IN LBS.	MINIMUM BRAKING STRENGTH IN LBS.
I	to 2,000	2,000
II	2,000 to 3,500	3,500
III	3,500 to 5,000	5,000

WARNING: Failure to properly attach safety chains between the trailer and tow vehicle can result in a runaway trailer.

WARNING: To avoid accidents, before trailering:

- Hitch only to ball size marked on coupling.
- Ball clamp must capture ball and lever or hand wheel is fully clamped.
- Cross safety chains under coupling.
- Allow only enough slack for turns.

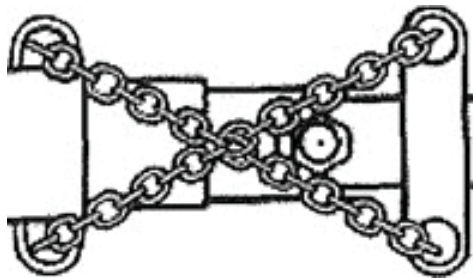

Bottom View

The safety chains on your trailer are an added insurance that it will not become detached from the tow vehicle. All safety chains are provided with an added clasp to keep them from becoming accidentally detached from the tow vehicle. Your trailer hitch on the tow vehicle should have two attaching holes or rings for attaching the safety chains, preferably one on each side of the ball hitch. Crisscross the chains under the tongue, the chain on the left side of the trailer tongue attached to the right side of the ball hitch, the chain on the right side of the trailer tongue attached to the left side of the ball hitch.

This prevents the trailer tongue from dropping to the road should the coupler or ball hitch fail. The chains should be rigged as tight as possible with just enough slack to allow tight turns to be made. This can be

accomplished by twisting the chain hook in a clockwise or counterclockwise direction thus twisting the link spacing and making the chain shorter. Also by keeping your chains as short as possible you prevent them from dragging on the road and wearing the chain links. If for any reason you find it necessary to replace a safety chain, use only original equipment.

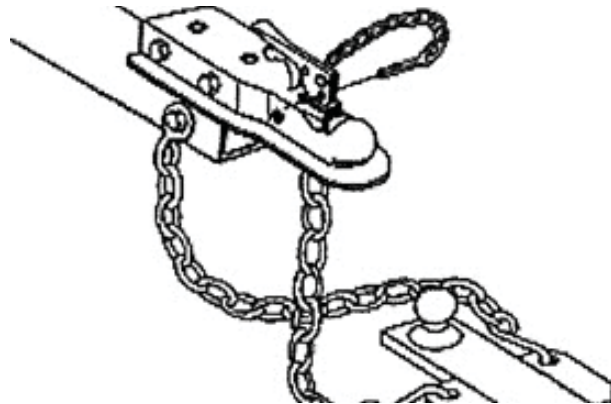

Load-Carrying Capacity

Located on the front left-hand side of the frame, (either the inside or the outside) is the VIN (Vehicle Identification Number) tag. It will show the GVWR (Gross Vehicle Weight Rating) which is the maximum load that can be applied to the tires on the trailer. The GVWR and the carrying capacity of the trailer are based on the tire size installed on the trailer.

The GVWR is the maximum carrying capacity of the trailer with its respective tires. It may not necessarily equal the total GVWR of the trailer less the empty weight of the trailer because there may be another controlling factor such as frame strength that reduces the carrying capacity to what is listed on the VIN tag.

The tire label will list the tire size that was installed on the trailer as original equipment when it was sold to you, the consumer. It also lists the maximum carrying capacity of the trailer.

IMPORTANT: The total weight of the load must never exceed the weight of cargo listed on the tire label and/or the maximum load carrying capacity listed on the VIN tag on your trailer. The GVWR (Gross Vehicle Weight Rating) listed is the maximum total weight of the trailer with accessories and all cargo allowable to be carried on the tires that are installed on the trailer.

WARNING: Fishtailing caused from improper tongue weight on the tow vehicle hitch ball can cause loss of control of the tow vehicle and resulting serious injury or property damage.

CAUTION: The maximum load applied to the trailer must never exceed the carrying capacity of the trailer as stated on the VIN label and/or the tire placard. Doing so may cause failure of one or more component parts of the trailer causing potential damage to the trailer and/ or a potential accident. All concentrated loads must be spread over as large an area as possible to eliminate potential damage to the decking.

Shown below is an example of the tire label that is placed on your trailer showing the items just discussed above. Once you have familiarized yourself with the information supplied on the example tire label and VIN tag, check the tire size and capacity of your trailer as shown on the VIN tag on your trailer.

TIRE AND LOADING INFORMATION RENSEIGNEMENTS SUR LES PNEUS ET LE CHARGEMENT			
The weight of cargo should never exceed XXXX kg or XXXX lbs			
TIRE	SIZE	COLD TIRE PRESS.	
REAR	XXXXXXXX	XXX KPA (XX PSI)	
INTER	XXXXXXXXXX		
FRONT	XXXXXX		
SPARE	XXXXXX		
		SEE OWNERS MANUAL FOR ADDITIONAL INFORMATION VOIR LE MANUEL DE L'USAGER POUR PLUS DE RENSEIGNEMENTS	
MANUFACTURED BY: KARCHER NORTH AMERICA INC.		DATE OF MFG.:XX/XXXX	
GVWR (XXXX KG (XXXX LB))			
GAWR (EACH AXLE)	WITH TIRES	RIMS AT	COLD
XXXX KG (XXXX LB)	XXXX	XXXX	XXX KPA (XX PSI) SINGLE
THIS VEHICLE CONFORMS TO ALL APPLICABLE U.S. FEDERAL MOTOR VEHICLE SAFETY STANDARDS IN EFFECT ON THE DATE OF MANUFACTURE SHOWN ABOVE.			
V.I.N. : XXXXXXXXXXXXXXXXXXXX		TYPE : TRAILER	TRX-XXXX

Proper Weight Distribution & Tongue Weight

Ensuring that your trailer has the proper GVWR is very important. Once that has been established and you have the load on the trailer it is equally important that you have proper weight distribution.

Tongue Weight

The tongue weight on your trailer is 10%-15% of the total weight of the trailer and all the cargo that it is carrying. This is the amount of weight that is then transferred to the tow vehicle through the ball hitch.

Example: The total weight of the trailer with load is 800 pounds. The tongue weight should not be less than 80 pounds (10%).

Too light of tongue weight can cause the trailer to “fish-tail” (sway Weight Rating) as you travel down the highway. This creates excessive strains on the tow vehicle, hitch and on the trailer itself. It can very easily lead to an accident.

To adjust for too light of a tongue weight the load must be shifted forward with respect to the axle. This will increase the weight that is transferred to the tongue. Adjustments should be made until the tongue weight falls within 10% -15% recommended range. Likewise, if you have too much tongue weight adjust the weight backwards with respect to the axle until the tongue weight falls in the recommended range

Tow vehicles vary on how much tongue weight they can support for proper towing.

Caster Operations

This trailer has a caster for manual transporting while using the pressure washer and to keep the trailer tongue off the ground when not trailering.

WARNING: The caster must be in the up position when trailering the unit.

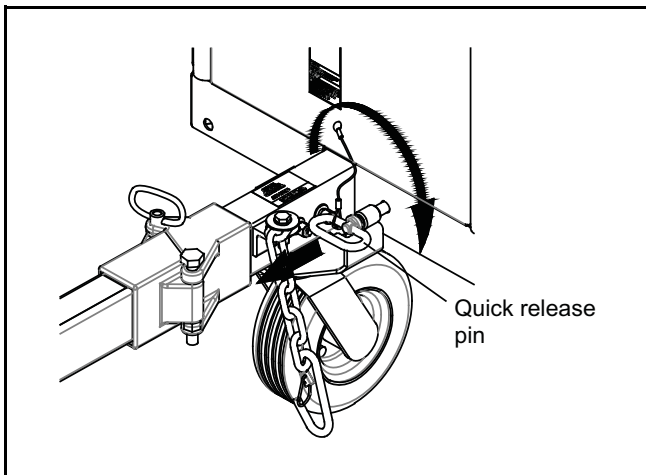

STEP 1: Release the quick release pin by rotating it clockwise. Pull Quick release pin from receptacle. Rotate the caster clockwise.

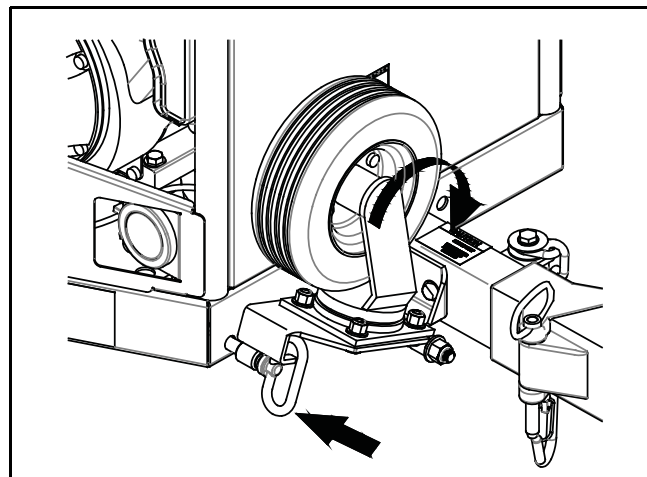

STEP 2: Insert quick release pin in receptacle. Lock quick release pin in place by rotating pin counter clockwise. Reverse step to lower caster.

NOTE: Before towing, diesel shut-off valve must be in the OFF position.

Trailer Brake Operations

WARNING: To avoid injury, the trailer brake must be set when operating the pressure washer or when not in use.

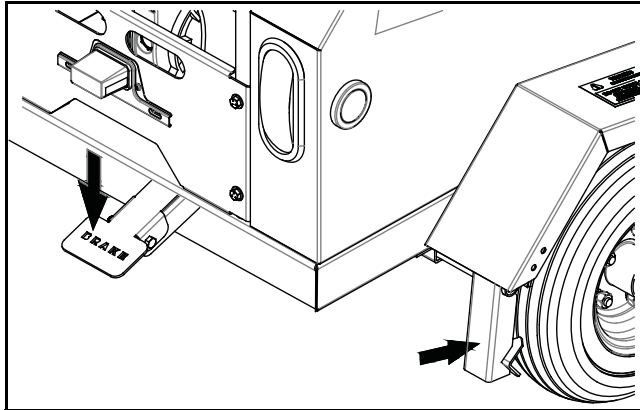

To set the brake, press down on the brake pedal until it engages on the back tires.

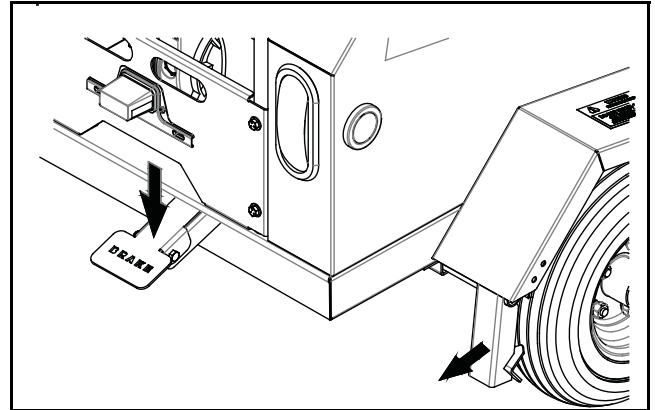

To release the brake, push the center of the brake to release see that it has disengaged from the back tire.

CAUTION: This brake has a spring mechanism that will return brake to its dis-engaged state. Make sure foot or hand is moved out of the pinch point area.

Tire Pressure

Proper air pressure for your tires is printed on the sidewall. Check pressure while tires are cold. Do not raise or lower pressure to meet load. Pressure other than recommended pressure will lead to excessive tire wear or tire failure. Balancing recommended.

Wheels

Check wheels for hole elongation or “out of round”. This condition can be caused by lug nuts not being tight or being too tight. Trailer wheels can be damaged by chuck holes or curb jumping. You may not be aware of the road shock to the wheels without periodic checks. Replace any wheel that is bent. Replace any wheel if you see elongation of the bolt holes.

Wheel Lugs

Wheel lug nuts must be tightened with a torque wrench. Refer to the chart below for proper torque.

1. Start all bolts or nuts by hand to prevent cross threading.
2. Tighten bolts or nuts following sequence at right.
3. The tightening of the fasteners should be done in stages. Following the recommended sequence, tighten fasteners per wheel torque chart below.
4. Wheel nuts/bolts should be torqued before first road use and after each wheel removal. Check and re-torque after the first 10 miles, 25 miles and again at 50 miles. Check periodically thereafter.

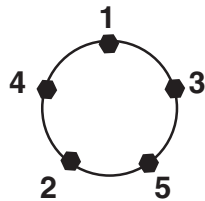

Wheel Torque Requirements

WHEEL SIZE	TORQUE SEQUENCE		
	1st Stage	2nd Stage	3rd Stage
16"	20 - 25	50 - 60	80-90

Ball Coupler Hitches

Coupler assembly includes a latch lever and latch lever safety pin or hitch pin. Be sure the latch lever is locked and the pin properly secured before moving your trailer. The pin can be engaged fully only if ball is properly seated in the coupler.

Tires

Before mounting tires onto wheels make certain that the rim size and contour is approved for the tire as shown in the Tire and Rim Association Yearbook or the tire manufacturer’s catalog. Also make sure the tire will carry the rated load. If the load is not equal on all tires due to trailer weight distribution, use the tire rated for the heaviest wheel position.

NOTE: The capacity rating molded into the sidewall of the tire is not always the proper rating for the tire if used in a trailer application. Use the following guideline:

1. LT and ST tires: use the capacity rating molded into the tire.
2. Passenger Car Tires: Use the capacity rating molded into the tire sidewall divided by 1.10.

Use tire mounting procedures as outlined by the Rubber Manufacturer’s Association or the tire manufacturers.

NOTE: Tire wear should be checked frequently because once a wear pattern becomes firmly established in a tire it is difficult to stop, even if the underlying cause is corrected.

WEAR PATTERN	CAUSE	ACTION
Center Wear	Over Inflation	Adjust pressure to particular load per tire catalog.
Edge Wear	Under Inflation	Adjust pressure to particular load per tire catalog.
Side Wear	Loss of camber or overloading	Make sure load doesn't exceed axle rating. Align at alignment shop.
Toe Wear	Incorrect toe-in	Align at alignment shop.
Cupping	Out of balance	Check bearing adjustment and balance tires.
Flat Spots	Wheel lockup & tire skidding	Avoid sudden stops when possible and adjust brakes.

Trailer Component Identification

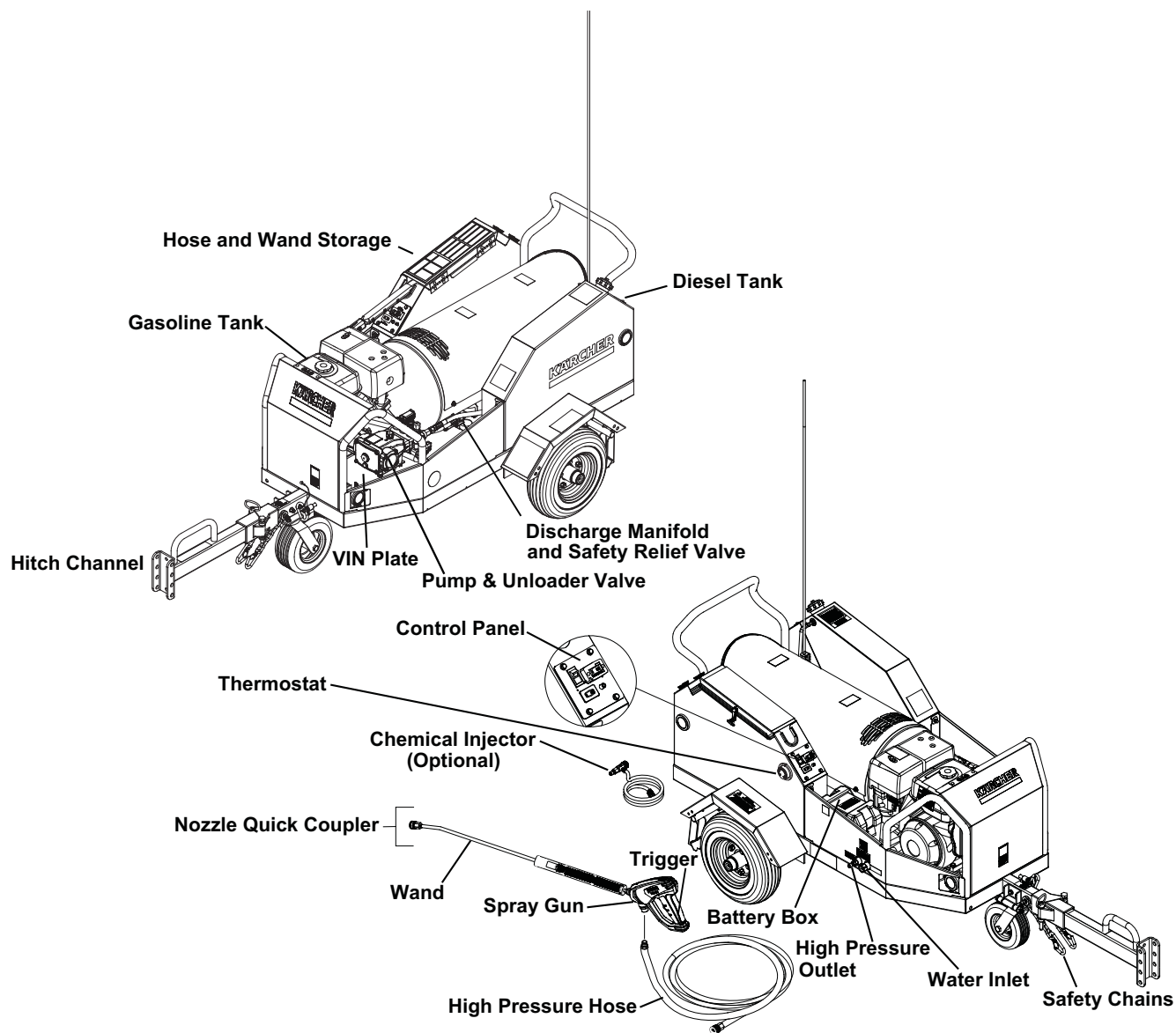

Pump — Delivers a specific GPM to the high pressure nozzle which develops pressure.

Spray Gun — Controls the application of water and detergent onto cleaning surface with trigger device. Includes safety latch.

Detergent Injector — Allows you to siphon and mix detergents.

Wand — Must be connected to the spray gun.

High Pressure Hose — Connect one end to water pump high pressure discharge nipple and the other end to spray gun.

Thermostat — Control the coil water output temperature.

Safety Relief Valve — Secondary pressure release in the unlikely event the unloader valve fails.

Unloader Valve — Safety device which, when the spray gun closes, prevents over pressurization.

NOTE: If trigger on spray gun is released for more than 2 minutes, water will leak from the pump protector. Warm water will discharge from pump protector onto floor. This system prevents internal pump damage.

Accessory Assembly Instructions

Handle Installation

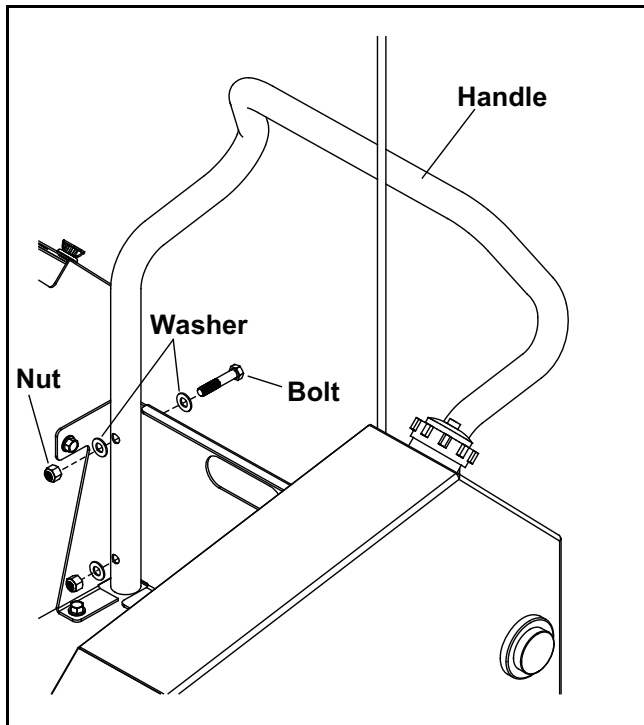

Align the 4 holes in the handle with the holes in the back plate, install the fasteners and washers supplied. (See Hose Box and Fuel Tank pages for fastener part numbers.)

NOTE: Fastener assembly torque to install handle: 10 ft-lbs (due to hollow tube handle.)

Safety Rod installation

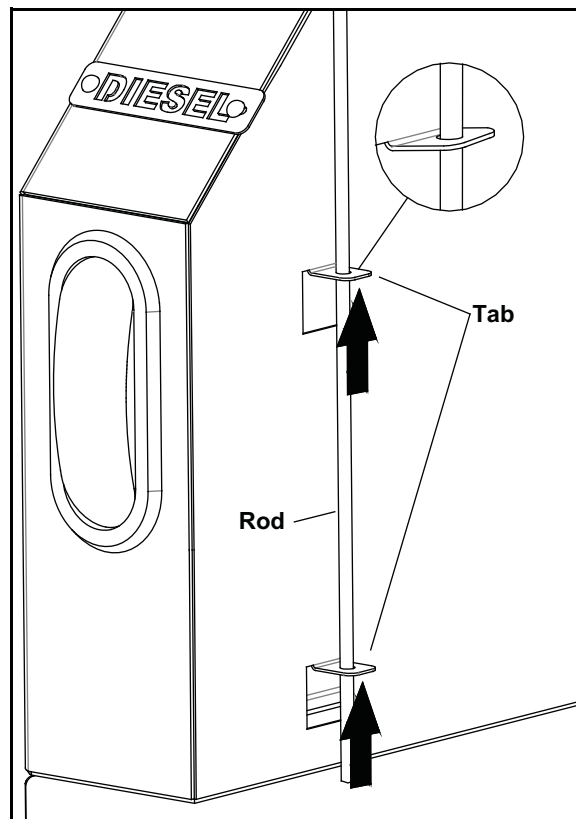

Slide the rod through both holes in the tabs. To secure rod, bend both tabs up slightly, until the rod does not move freely. (See Hose Box and Fuel Tank pages for fastener part numbers.)

Assembly Instructions

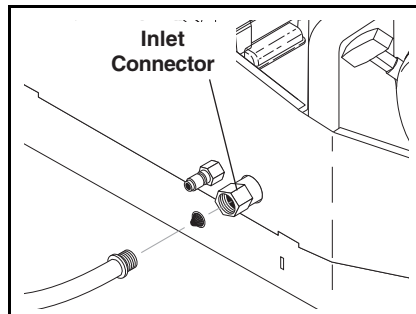

STEP 1: Attach a 5/8" garden hose to inlet connector. Minimum flow should be 5 gpm.

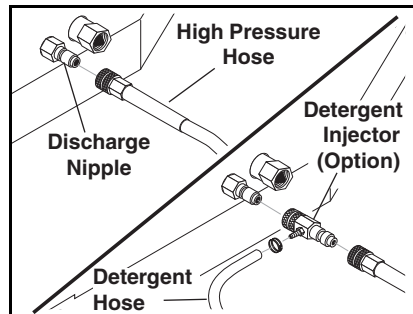

STEP 2: Attach high pressure hose to discharge nipple using quick coupler. Lock coupler securely into place by pulling back coupler collar and inserting it onto discharge nipple, then pushing collar forward to lock in place.

NOTE: If using detergent injector, attach detergent injector to discharge nipple using quick coupler. Attach high pressure hose to other end of detergent injector.

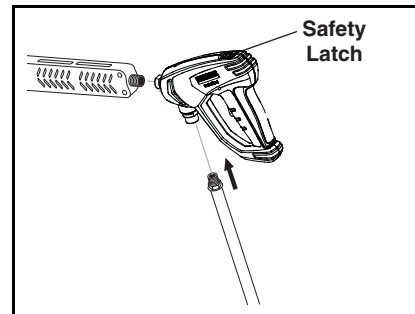

STEP 3: Attach wand to spray gun using teflon tape on threads to prevent leakage. Attach swivel connector on discharge hose to spray gun using teflon tape on threads. Attach swivel connector on high pressure hose to spray gun using teflon tape on threads. Engage safety latch to prevent from triggering gun.

STEP 6: On electric start models,

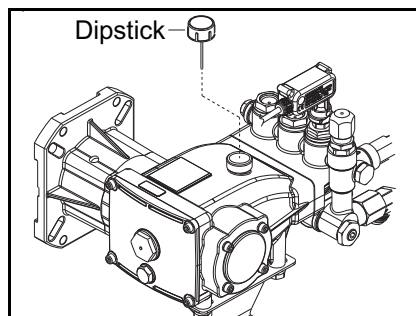

STEP 4: Check oil level on sight glass on backside of pump. Oil should be visible one-half way up sight glass (10-40W non-foaming). The oil level can also be checked by using the dipstick on the top of the pump.

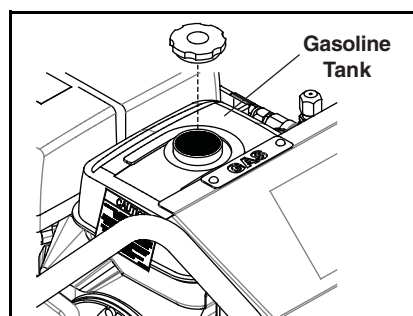

STEP 5: Fill gasoline tank and check engine oil.

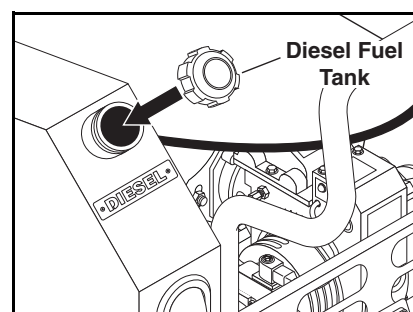

Fill diesel tank with diesel fuel.

CAUTION: Do not confuse diesel fuel and gasoline when filling tanks. Keep proper fuel in proper tanks.

NOTE: Diesel Fuel Shut-off must be in the ON position prior to turning on burner.

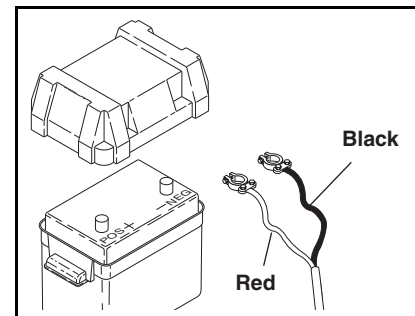

you will need to install a battery making sure that the red cable is attached to the positive terminal. Use a Group U1 garden tractor style type of battery rated for 300 CCA (battery not included).

NOTE: Battery is required for burner to operate.

CAUTION: These machines are intended to be protected from outside environments.

CAUTION: Risk of injury. Disconnect battery ground terminal before servicing.

Installation

Place machine in a convenient location providing ample support, draining and room for maintenance.

This machine is intended for outdoor use. Machine must be stored indoors when not in use.

Location

The location should protect the machine from damaging environmental conditions, such as wind, rain, and freezing.

1. This machine should be run on a level surface where it is not readily influenced by outside sources such as strong winds, freezing temperatures, rain, etc. It should be located to allow accessibility for refilling of fuel, adjustments and maintenance. Normal precautions should be taken by the operator of the machine to prevent moisture from reaching the electrical controls.
2. It is recommended that a partition be made between the wash area and the machine to prevent water spray from coming in contact with the machine. Excess moisture reaching any electric components or electrical controls will reduce machine life and may cause electrical shorts.
3. During installation of the machine, beware of poorly ventilated locations or areas where exhaust fans may cause an insufficient supply of oxygen. Sufficient combustion can only be obtained when there is a sufficient supply of oxygen available for the amount of fuel being burned. If necessary to install a machine in a poorly ventilated area outside, fresh air may have to be piped to the burner and a fan installed to bring air into the machine.

Avoid small locations or areas near exhaust fans.

Placement

Do not locate near any combustible material. Keep all flammable material at least 20 feet away.

Allow enough space for servicing the machine.

Local code will require certain distances from floor and walls. (Two feet away from walls should be adequate.)

Water Source

The water source for the pressure washer should be supplied by a minimum 5/8" I.D. garden hose with a city water pressure of not less than 5 GPM. If the water supply is inadequate, or if the garden hose is kinked, the attached pressure washer will run very rough and the burner will not fire.

Connection

Connect the wand, nozzle, hose and spray gun (where applicable). On pipe thread connections, use Teflon tape to avoid water leaks. (See Component Identification).

Operating Instructions

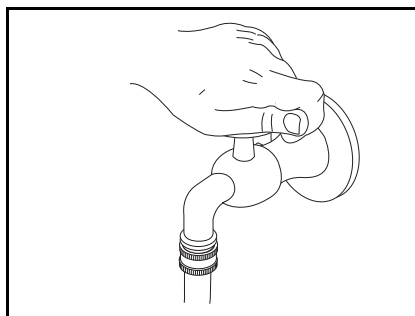

STEP 1: Turn water on.

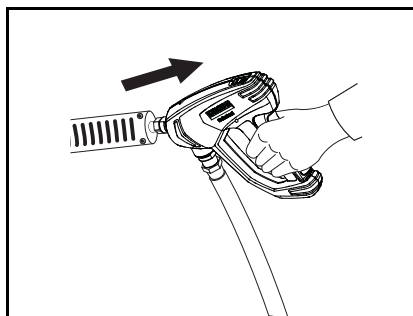

STEP 2: Grip spray gun handle securely and pull trigger.

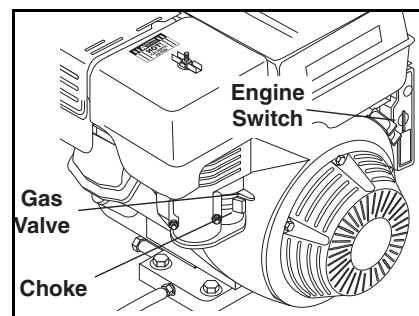

STEP 3: Turn the engine key switch to the on position till the engine starts.

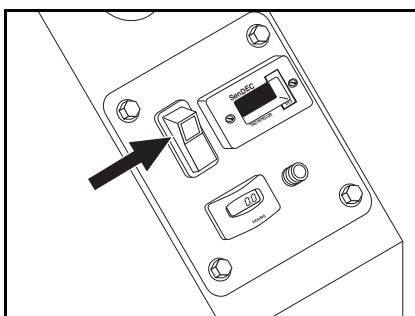

STEP 4: For hot water, turn thermostat to desired temperature and turn burner switch to the on position.

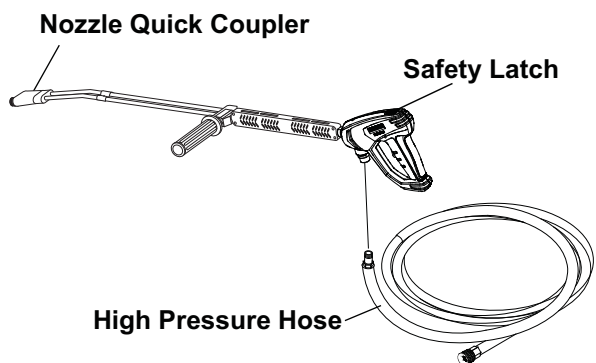

NOTE: High pressure nozzle must be inserted at end of wand to obtain high pressure. To apply detergent, read operator's manual.

Detergents & General Operating Techniques



WARNING: Some detergents may be harmful if inhaled or ingested, causing severe nausea, fainting or poisoning. The harmful elements may cause property damage or severe injury.

STEP 1: Connect high pressure hose to injector with quick coupler (check to make sure locking coupler sleeves are in proper position before

applying water pressure. If using detergent injector, connect it to discharge nipple on machine.

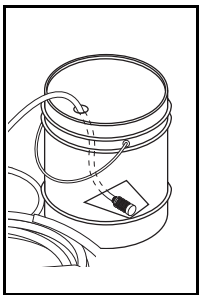
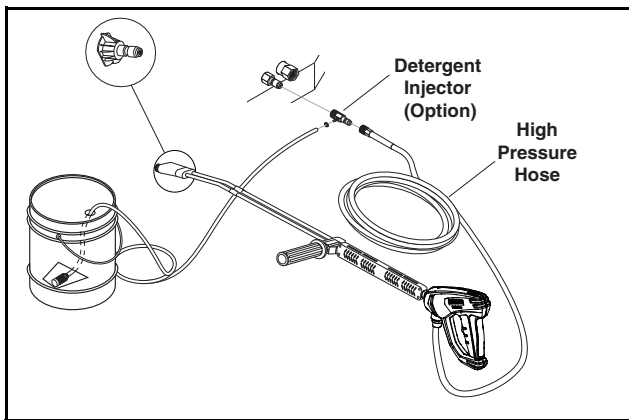

STEP 2: Use detergent designed specifically for pressure washers. Household detergents could damage the pump. Prepare detergent solution as required by the manufacturer. Fill a container with pressure washer detergent. Place the filter end of detergent suction tube into the detergent container.

STEP 3: Apply safety latch to spray gun trigger. Turn variable pressure control handle until discharge water exits both tubes. Secure black detergent nozzle into quick coupler if you have a single wand. **NOTE:** Detergent cannot be applied using Red, Yellow, Green or White nozzles.

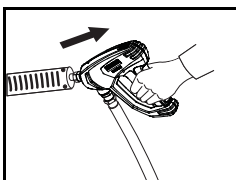

STEP 4: With the engine running, pull trigger to operate machine. Liquid detergent is drawn into the machine and mixed with water. Apply detergent to work area. Do not allow detergent to dry on surface.

Thermal Pump Protection

If you run the engine on your pressure washer for 3-5 minutes without pressing the trigger on the spray gun, circulating water in the pump can reach high temperatures. When the water reaches this temperature, the pump protector engages and cools the pump by discharging the warm water onto the ground. This thermal device prevents internal damage to the pump.

Cleaning Tips

Pre-rinse cleaning surface with fresh water. Place detergent suction tube directly into cleaning solution and apply to surface at low pressure (for best results, limit your work area to sections approximately 6 feet square and always apply detergent from bottom to top). Allow detergent to remain on surface 1-3 minutes. Do not allow detergent to dry on surface. If surface appears to be drying, simply wet down surface with fresh water. If needed, use brush to remove stubborn dirt. Rinse at high pressure from top to bottom in an even sweeping motion keeping the spray nozzle approximately 1 foot from cleaning surface. Use overlapping strokes as you clean and rinse any surface. For best surface cleaning action spray at a slight angle.

Recommendations:

- Before cleaning any surface, an inconspicuous area should be cleaned to test spray pattern and distance for maximum cleaning results.
- If painted surfaces are peeling or chipping, use extreme caution as pressure washer may remove the loose paint from the surface.
- Keep the spray nozzle a safe distance from the surface you plan to clean. High pressure wash a small area, then check the surface for damage. If no damage is found, continue to pressure washing.

CAUTION - Never use

- Bleach, chlorine and other corrosive chemicals
- Liquids containing solvents (i.e., paint thinner, gasoline, oils)
- Tri-sodium phosphate products
- Ammonia products
- Acid-based products

These chemicals will harm the machine and will damage the surface being cleaned.

Rinsing

It will take a few seconds for the detergent to clear. Apply safety latch to spray gun. Remove black soap nozzle from the quick coupler. Select and install the desired high pressure nozzle. **NOTE:** You can also stop detergent from flowing by simply removing detergent siphon tube from bottle.

Shutting Down And Clean-Up

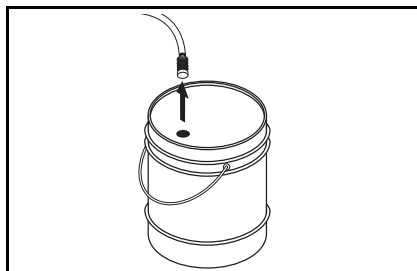

STEP 1: Remove detergent suction tube from container and insert into 1 gallon of fresh water. Turn variable pressure wand handle for low pressure or connect the black detergent nozzle. Pull trigger on spray gun and siphon water for one minute.

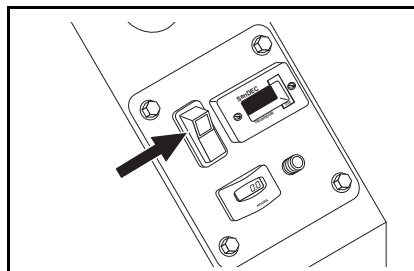

STEP 2: Turn burner switch off and continue spraying water, allowing the water to cool. After water has cooled to less than 100°F, turn off engine. Protect from freezing.

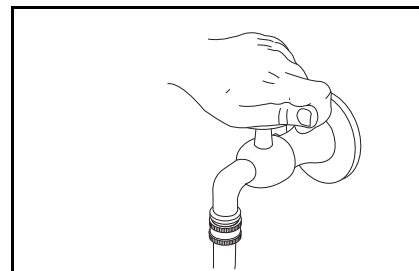

STEP 3: Turn off water supply.

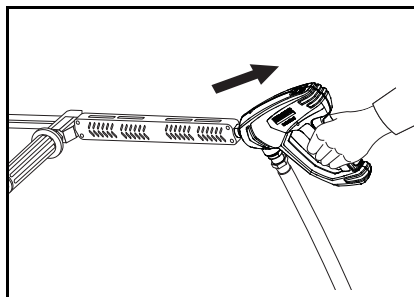

STEP 4: Turn garden hose water off. Open the spray gun to relieve remaining pressure.

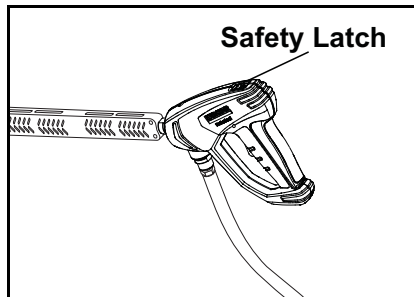

STEP 5: Lock trigger gun safety lever to prevent unintentional pulling of trigger.

Storage

CAUTION: Always store your pressure washer in a location where the temperature will not fall below 32°F (0°C). The pump in this machine is susceptible to permanent damage if frozen. FREEZE DAMAGE IS NOT COVERED BY WARRANTY.

1. Stop the pressure washer, squeeze spray gun trigger to release pressure.
2. Detach water supply hose and high pressure hose.
3. Turn on the machine for a few seconds, until remaining water exits. Turn motor off immediately.
4. Drain the fuel from the fuel tank.

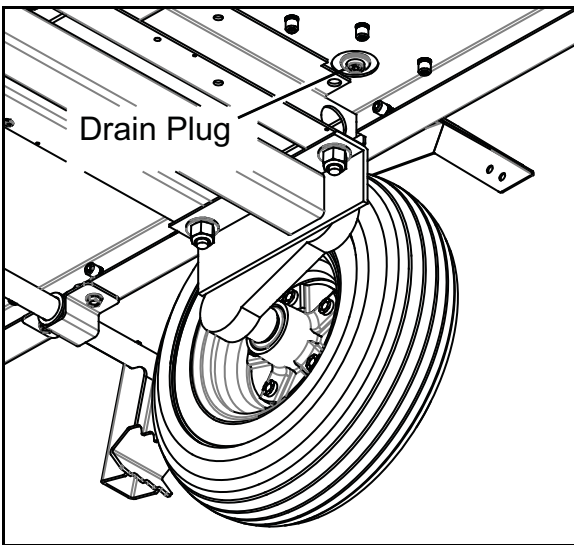

5. Do not allow high pressure hose to become kinked.
6. Store the machine and accessories in a room which does not reach freezing temperatures.

CAUTION: Failure to follow the above directions will result in damage to your pressure washer.

When the pressure washer is not being operated or is being stored for more than one month, follow these instructions:

1. Replenish pump oil to upper level.
2. Drain fuel from fuel tank, fuel line and filter.
3. Cover the pressure washer and store in a clean, dry place that is well ventilated away from open flame or sparks.

After Extended Storage

CAUTION: Prior to restarting, thaw out any possible ice from pressure washer hoses, spray gun or wand.

Preventative Maintenance

1. Use clean fuel — kerosene, No. 1 home heating fuel or diesel fuel. Clean or replace fuel filter every 100 hours of operation. Avoid water contaminated fuel as it will seize up the fuel pump. De-soot coils monthly. Use an additive if diesel is being used.
2. Check to see that the attached pressure washer water pump is properly lubricated.
3. Follow winterizing instructions to prevent freeze damage to pump and coils.
4. Always neutralize and flush detergent from system after use.
5. If water is known to be high in mineral content, use a water softener on your water system, or de-scale as needed.
6. Do not allow acidic, caustic or abrasive fluids to be pumped through the system.
7. Always use high grade quality cleaning products.
8. Never run attached pressure washer pump dry for extended periods of time.
9. If machine is operated with smoky or eye burning exhaust, coils will soot up, preventing water from reaching maximum operating temperature. (See section on Maintenance and Service).
10. Never allow water to be sprayed on or near the motor or burner assembly or any electrical component.
11. Delime coils as per instructions.

It is advisable, periodically, to visually inspect the burner. Check air inlet to make sure it is not clogged or blocked. Wipe off any oil spills and keep equipment clean and dry.

The areas around the pressure washer should be kept clean and free of combustible materials, gasoline and other flammable vapors and liquids.

The flow of ventilating air to the burner must not be blocked or obstructed in any manner.

Maintenance And Service

Unloader Valves

Unloader valves trap pressure in the line when a shut-off spray gun is closed. Machines with unloader valves are preset and tested at the factory before shipping. Tampering with the factory settings may cause personal injury and/or property damage and will void the manufacturer's warranty.

Winterizing Procedure

Damage due to freezing is not covered by warranty. Adhere to the following cold weather procedures whenever the washer must be stored or operated outdoors under freezing conditions.

During winter months, when temperatures drop below 32°F, protecting your machine against freezing is necessary. Store the machine in a heated room. If this is not possible then mix a 50/50 solution of anti-freeze/water or windshield washer fluid with water in a 5 gallon bucket. Place a short section of garden hose into the bucket and connect it to the machine. Elevate the bucket and turn the pump on to siphon the anti-freeze through the machine. If compressed air is available, an air fitting can be screwed into the inlet connector and by injecting compressed air, all water will be blown out of the system.

High Limit Hot Water Thermostat

For safety, each machine is equipped with a high limit control switch. In the event the temperature of the water should exceed its operating temperature, the high limit control will turn the burner off until the water cools.

Pumps

Use only 10-40W weight non-foaming oil. Change oil after first 50 hours of use. Thereafter, change oil every year or at 500 hour intervals. Oil level should be checked by using the dipstick found on the top of the pump or by the red dot visible through the oil gauge window. Oil should be maintained at that level.

Cleaning of Coils

In alkaline water areas, lime deposits can accumulate rapidly inside the coil pipes. This growth is increased by the extreme heat build up in the coil. The best prevention for liming conditions is to use high quality cleaning detergents. In areas where alkaline water is an extreme problem, periodic use of deliming powder will remove lime and other deposits before coil becomes plugged.

Deliming Coils With A Pressure Washer

Periodic flushing of coils is recommended.

1. Fill a 5 gallon bucket with 4 gallons of water, then add 1 lb. of deliming powder. Mix thoroughly.
2. Remove the high pressure nozzle from the pressure wand and put the wand into the bucket. Secure the trigger on the spray gun into the open position.
3. Attach a short section (3-5 ft.) of garden hose to the attached pressure washer to siphon solution from the elevated bucket. Start up pressure washer, allowing solution to be pumped through pressure washer and into HPB coils and back into the bucket. Solution should be allowed to circulate 2-4 hours.
4. After circulating solution flush entire system with fresh water.

Fuel

Use clean fuel oil that is not contaminated with water and debris. Replace fuel filter and drain tank every 100 hours of operation.

Use No. 1 or No. 2 Heating Oil (ASTM D306) only. **NEVER** use gasoline in your burner tank. Gasoline is more combustible than fuel oil and a serious explosion could result. **NEVER** use crankcase or waste oil in your burner. Fuel unit malfunction could result from contamination.

Fuel Control System

These machines utilize a fuel solenoid valve located on the fuel pump to control the flow of fuel to the combustion chamber. This solenoid valve, which is normally closed, is activated by a flow switch when water is flowing through it. When an operator releases the trigger on the spray gun, the flow of water through the flow switch stops, turning off the current to the fuel solenoid. The solenoid then closes, shutting off the supply of fuel to the combustion chamber. Controlling the flow of fuel in this way allows for an instantaneous burn or no burn situation, thereby eliminating high and low water temperatures, and combustion smoke normally associated with machines incorporating a spray gun.

CAUTION: Periodic inspection is recommended to insure that the fuel solenoid valve functions properly. This can be done by operating the machine and checking to see that when the trigger on the spray gun is in the off position, the burner is not firing.

Burner Nozzle

Keep the tip free of surface deposits by wiping it with a clean, solvent-saturated cloth, being careful not to plug or enlarge the nozzle. For maximum efficiency, replace the nozzle each season.

Initial Air Adjustments

Allow sufficient air to obtain a clean burning flame by loosening the lock screws and moving the air shutter and if necessary the bulk air band.

Reduce the air supply until the flame tips appear slightly smoky then increase the air just enough to cause the flame tips to appear absolutely clean.

Oil Burner

Burner Air Adjustment: The oil burner on this machine is preset for operation at altitudes below 500 feet. If operated at higher altitudes, it may be necessary to adjust the air band for a #1 or #2 smoke spot on the Bacharach scale.

To adjust, start machine and turn burner ON. Loosen two locking screws found on the air band and close air band until black smoke appears from burner exhaust vent. Note air band position. Next, slowly open the air band until white smoke just starts to appear. Turn air band halfway back to the previously noted position. Tighten locking screws.

For higher altitudes, the air band opening may need to be increased; for lower altitude, the air band may need to be decreased.

For higher humidity, the air band opening may need to be increased; for lower relative humidity, the air band may need to be decreased.

For higher ambient temperatures the air band opening may need to be increased; for lower ambient temperatures, the air band opening may need to be decreased.

Adjust to your operating location's environment as needed for best smoke spot and performance compliant with local, state, and federal regulations.

Electrode Setting

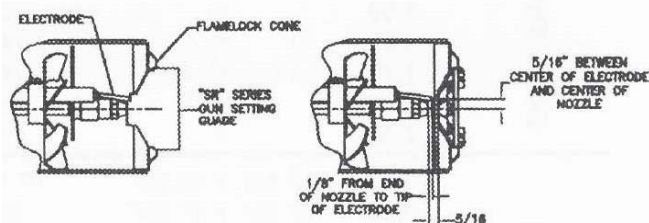

(For EHASR Only)

SR Series Gage

KNA Part Number #8.717-379.0

CAUTION: If white smoke appears from burner exhaust vent during start-up or operation, discontinue use and readjust air bands.

NOTE: If a flue is installed, have a professional serviceman adjust your burner for a #1 or #2 smoke spot on the Bacharach scale.

Fuel Pressure Adjustment

To adjust fuel pressure, First install a pressure gage into the port just after the pump fuel exit. Turn the adjusting screw (located at the regulator port) clockwise to increase, and counterclockwise to decrease. Do not exceed 200 psi or lower the pressure below 130 PSI, when checked at the post-pump pressure port.

The fuel pressure may need to be adjusted due to altitude. For every 500 ft altitude above sea level, the boiling point of water goes down 1 °F. At high altitude environments, this boiling point change may require the heat input to be lowered so the water input does not turn to steam earlier than at the factory settings and activate the pressure sensors and pressure relief equipment when the unit is operated and much higher altitudes from factory settings or local dealer site settings. Check with your dealer before making local site fuel pressure adjustments.

Also, as ambient temperature changes seasonally, the fuel temperature in the feed tank and air temperature inlet can impact fuel flow. In more extreme temperatures, this local-site adjustment may also require different fuel nozzles for fuel inlet temperatures that are at seasonal extremes (higher or lower) in locations where the temperature changes are beyond moderate temperatures of between 40°F and 90°F. Colder temperatures will make for a thicker flow and less fine a fuel spray while hotter temperatures will make for a thinner flow a more fine spray with the same nozzle. Consider alternate nozzle configurations from the

baseline factory-supplied nozzle for operating in such temperature extremes if performance is not meeting needs with air band and fuel pressure settings alone.

NOTE: When changing fuel pump, a by-pass plug must be installed in return line port or fuel pump will not prime.

Removal of Soot and Heating Coil

In the heating process, fuel residue in the form of soot deposits may develop on the heating coil and block air flow which will affect burner combustion. When soot has been detected on visual observation, the soot on the coil must be washed off after following the coil removal steps.

1. Remove the top wrap by unscrewing the four screws from the sides and lift the top wrap off.
2. Remove Insulation.
3. Remove the two pipe nipples and associated fittings.
4. Lift the coil out of the outer wrap.

CAUTION: The coil weighs about 80 lbs. Use proper lifting techniques.

5. Clean, repair and replace the coil by reversing the above steps.

Coil Reinstallation

Reinstall by reversing the above steps 5 through 1.

NOTE: The 12 VDC burner systems can draw as much as 18 amps. For such motors to run properly, the battery and engine charging system must be kept in good condition, and the engine must run fast enough to adequately charge the battery. Do not throttle down the engine for any length of time.

Hub Inspection Removal- Replacement And Adjustments

A. Removal of Hub

1. Remove wheel
2. Remove grease cap
3. Remove cotter pin or bend tang washer on Posi-Lube
4. Unscrew the spindle nut counter clockwise
5. Remove spindle washer
6. Remove hub from spindle

B. Seal Inspection and Replacement

1. Seals should be replaced each time the hub is removed.
2. Pry the seal out of the hub with a screwdriver.
3. Tap new seal into place.

C. Bearing Maintenance, Adjustments, and Replacement

1. Inspect for corrosion and wear.
2. If any rust or wear exists on the bearing then remove and replace.
3. If bearings are found to be in good condition, then cleaning and repacking the grease is all that is needed.

NOTE: Do not spin bearings with compressed air.

4. Hand pack each bearing individually using a premium lithium base wheel bearing grease.
5. Reinstall the hub, reversing the procedure above using the bearing adjustment procedures below.
6. If you have the Posi-Lube system refer to the "Posi-Lube Lubrication Procedure".

D. Bearing Adjustment

Feel and Drag Method

Tighten slotted nut until hub drags slightly when rotated. (Rotating the hub while tightening the nut seats the bearing.) Loosen the slotted nut 1/6 turn (1 hex) to align nut slot with the cotter pin hole. Wheel should turn freely. Insert new cotter pin through nut and spindle. If necessary loosen, never tighten, nut to align slot with the hole in the spindle. Bend one leg of cotter pin over the end of the spindle and the other leg over the nut. Tap legs slightly to set. Cotter pin must be tight. If equipped with Posi-Lube, bend tang back into position.

Torque Wrench Method

Make sure nut is loose. Tighten nut with torque wrench to an initial torque of 50 ft. lbs. Loosen nut from initial torque and fingertighten. Insert new cotter pin through nut and spindle. If equipped with Posi-Lube, reset tang. If necessary loosen, never tighten, nut to align slot with the hole in the spindle. Bend one leg of cotter pin over the end of the spindle and the other leg over the nut. Tap legs slightly to set. Cotter pin must be tight.

Posi-lube Lubrication Procedure

1. Remove the rubber cap at end of the grease cap.
2. Using a standard grease gun place the tip onto the grease fitting at the end of the spindle.
3. Pump the grease into the fitting as you continue pressure you will notice the old grease coming out at the cap. When you begin to see the new grease, remove the gun and clean off any excess and replace the rubber cap.

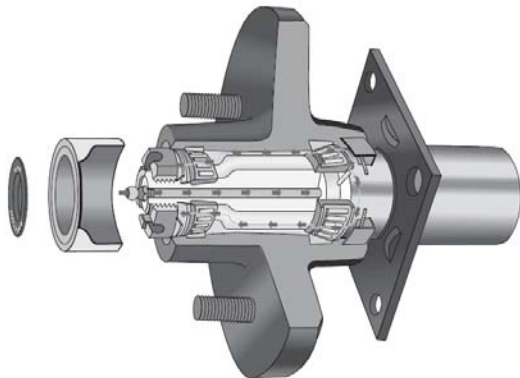

Troubleshooting

PROBLEM	POSSIBLE CAUSE	SOLUTION
LOW OPERATING PRESSURE	Faulty pressure gauge	Install new gauge.
	Insufficient water supply	Use larger garden hose; clean filter washer at water inlet.
	Old, worn or incorrect spray nozzle	Match nozzle number to machine and/or replace with new nozzle.
	Plumbing or hose leak	Check plumbing system for leaks. Re-tape leaks with teflon tape.
	Faulty or mis-adjusted unloader valve (where applicable)	Adjust unloader for proper pressure. Install repair kit when needed.
	Worn packing in pump	Install new packing kit.
	Fouled or dirty inlet or discharge valves in pump	Clean inlet or discharge valves.
	Worn inlet or discharge valves	Replace with valve kit.
DETERGENT NOT DRAWING	Air leak	Tighten all clamps. Check detergent lines for holes.
	Valve in the injector head may be blocked, dirty or damaged	Clean or replace valve in injector.
	Filler screen on detergent suction hose plugged	Clean or replace.
	Dried up detergent plugging metering valve	Disassemble and clean thoroughly.
	High viscosity of detergent	Dilute detergent to specifications.
	Hole in detergent line(s)	Repair hole.
	Low detergent level	Add detergent if needed.
	Discharge water temperature above 180°F	Lower discharge water temperature.
PUMP RUNNING NORMALLY BUT PRESSURE LOW ON INSTALLATION	Pump sucking air	Check water supply and possibility of air seepage.
	Valves sticking	Check and clean or replace if necessary.
	Unloader valve seat faulty	Check and replace if necessary.
	Nozzle incorrectly sized	Check and replace if necessary (See serial plate for proper size).
	Worn piston packing	Check and replace in necessary.
FLUCTUATING PRESSURE	Valves worn	Check and replace if necessary.
	Blockage in valve	Check and replace if necessary.
	Pump sucking air	Check water supply and air seepage at joints in suction line.
	Worn piston packing	Check and replace if necessary.
PUMP NOISY	Air in suction line	Check water supply and connections on suction line.
	Broken or weak inlet or discharge valve springs	Check and replace if necessary.
	Excessive matter in valves	Check and clean if necessary.
	Worn bearings	Check and replace if necessary.

PROBLEM	POSSIBLE CAUSE	SOLUTION
LOW WATER TEMPERATURE	Improper fuel or water in fuel	Drain fuel tank and replace with proper fuel.
	Low fuel pressure	Increase fuel pressure.
	Weak fuel pump	Check fuel pump temperature. Replace pump if needed.
	Fuel filter partially clogged	Replace as needed.
	Soot build up on coils	Clean coils with soot remover.
	Lime build up on coils	Clean inside of coils using coil cleaner.
	Improper burner nozzle	See Burner Specifications.
WATER TEMPERATURE TOO HOT	Incoming water to machine warm or hot	Lower incoming water temperature.
	Fuel pump pressure too high	Lower fuel pressure.
	Fuel pump defective	Replace fuel pump.
	Detergent line sucking air	Tighten all clamps. Check detergent line for holes.
	Defective high limit switch (thermostat)	Replace.
	Incorrect fuel nozzle size	See Burner Specifications.
	Insufficient water supplied	Check GPM to machine.
MACHINE SMOKES WHILE BURNER UNIT IS RUNNING OR UNIT SMOKES AT COLD-START ONLY WHEN BURNER IS OFF	Restricted water flow	Check nozzle for obstruction, proper size.
	Improper air adjustment	Readjust air bands on burner assembly
	Fuel pressure is low <140 psi for burner	Adjust fuel pump pressure to specifications
	Burner nozzle is plugged or dirty	Replace nozzle. Check parts breakdown for nozzle size
	Burner nozzle spray pattern is faulty	Replace nozzle. Check parts breakdown for nozzle size
	Heavy accumulation of soot on coils and burner assembly	Remove coils and burner assembly, clean thoroughly Call local dealer
	Misaligned electrode setting	Realign electrodes to specifications
	Obstruction in smoke stack	Check for insulation blockage or other foreign objects
	Low engine RPM	Increase RPM to correct specs. See serial plate
Fuel Pressure is too high for clean burn (fuel PSI above 140 and below 200) and smokes when burner is off	Reduce fuel pressure PSI/Increase air band set for cleaner without max water heat loss	

NOTE: For additional service information for the engine, refer to the engine Operation and Maintenance Manual included with pressure washers.

Pressure Washer Preventive Maintenance

This pressure washer was produced with the best available materials and quality craftsmanship. However, you as the owner have certain responsibilities for the correct care of the equipment. Attention to regular preventative maintenance procedures will assist in preserving the performance of your equipment. Contact your Pressure Washers dealer for maintenance. Regular preventative maintenance will add many hours to the life of your pressure washer. Perform maintenance more often under severe conditions.

Maintenance Schedule		
Engine Oil SAE 10W-30	Inspect	Daily
	Change	After first 25 hours
	Filter	Every 50 hours
Air Cleaner	Inspect	Every 50 hours or monthly
	Clean	Every 3 months
Battery level		Check monthly
Engine Fuel Filter		500 hours or 6 months
Spark Plug Maintenance		500 hours or 6 months
Clean Fuel Tank(s)		Annually
Replace Fuel Lines		Annually
Pump Oil (non-foaming 10-40W)	Inspect	Oil level daily
	Change	After first 50 hours, then every 500 hours or annually
Clean Burner Filter		Monthly (More often if fuel quality is poor)
Remove Burner Soot		Annually
Burner Adjustment/Cleaning		Annually
Replace Burner Nozzle		Annually
Descale Coil		Annually (More often if required)
Replace High Pressure Nozzle		Every 6 months
Replace Quick Connects		Annually
Clean Water Screen/Filter		Weekly
Replace HP Hose		Annually

Refer to Honda engine manual for maintenance and service questions

KÄRCHER

A thick, solid black horizontal bar that serves as an underline for the Kärcher brand name.

#9.807-942.0 - Printed in U.S.A. or Mexico