



# HC

# OPERATOR'S MANUAL

---

■ HC-232439

■ HC-232336

---

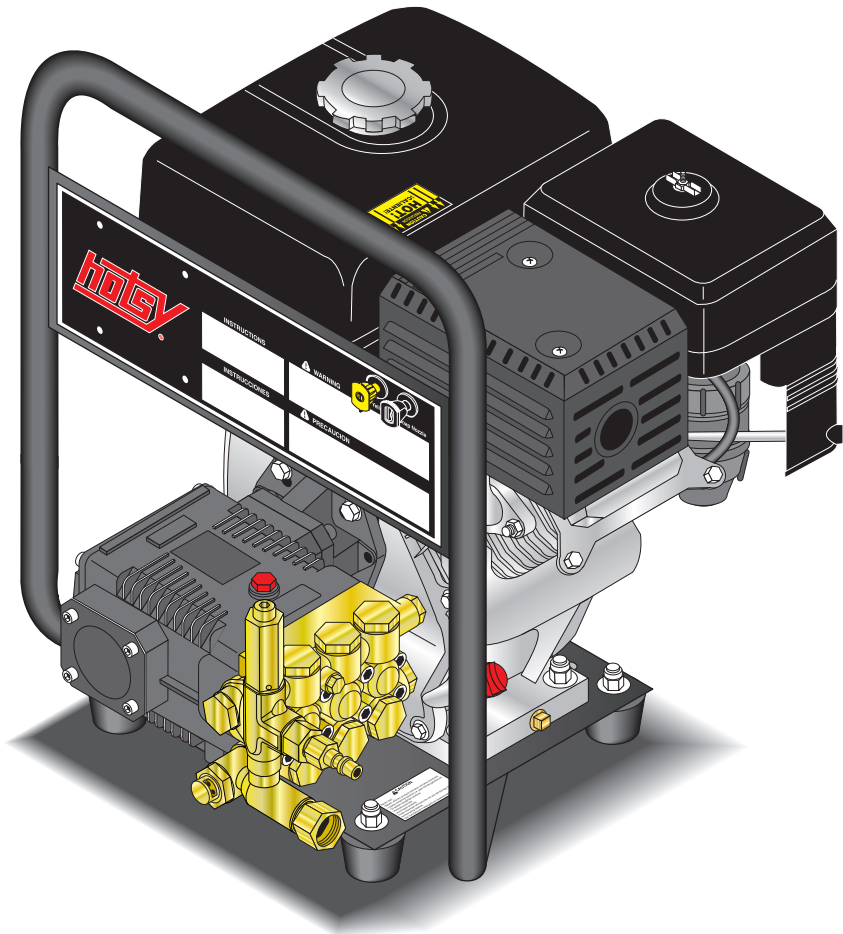

---

**SHOP PRESSURE WASHER PARTS**

shoppressurewasherparts.com | 888.269.0172

8.941-459.0



---

Important Safety Information .....	2-3
Component Identification .....	4
Assembly Instructions.....	5
Operating Instructions.....	6-7
Applying Detergent and General Operating Techniques.....	8
Shut Down and Clean-Up .....	9
Storage .....	9
Troubleshooting .....	10-11
Preventative Maintenance .....	12
Oil Change Record .....	12
Hose and Spray Gun Assembly.....	13

Model Number \_\_\_\_\_

Serial Number \_\_\_\_\_

Date of Purchase \_\_\_\_\_

The model and serial numbers will be found on a decal attached to the pressure washer. You should record both serial number and date of purchase and keep in a safe place for future reference.

# INTRODUCTION & IMPORTANT SAFETY INFORMATION

Thank you for purchasing this Pressure Washer. We reserve the right to make changes at any time without incurring any obligation.

## Owner/User Responsibility:

The owner and/or user must have an understanding of the manufacturer's operating instructions and warnings before using this pressure washer. Warning information should be emphasized and understood. If the operator is not fluent in English, the manufacturer's instructions and warnings shall be read to and discussed with the operator in the operator's native language by the purchaser/owner, making sure that the operator comprehends its contents.

Owner and/or user must study and maintain for future reference the manufacturers' instructions.

The operator must know how to stop the machine quickly and understand the operation of all controls. Never permit anyone to operate the engine without proper instructions.

## SAVE THESE INSTRUCTIONS

This manual should be considered a permanent part of the machine and should remain with it if machine is resold.

When ordering parts, please specify model and serial number. Use only identical replacement parts.

This machine is to be used only by trained operators.

## IMPORTANT SAFETY INFORMATION

**WARNING**



**READ OPERATOR'S MANUAL THOROUGHLY PRIOR TO USE.**

**WARNING: To reduce the risk of injury, read operating instructions carefully before using.**

1. Read the owner's manual thoroughly. Failure to follow instructions could cause malfunction of the machine and result in death, serious bodily injury and/or property damage.
2. Know how to stop the machine and bleed pressure quickly. Be thoroughly familiar with the controls.
3. Stay alert — watch what you are doing.

4. All installations must comply with local codes. Contact your electrician, plumber, utility company or the selling distributor for specific details.

**WARNING**



**RISK OF ASPHYXIATION: USE THIS PRODUCT ONLY IN A WELL VENTILATED AREA.**

**WARNING: Risk of asphyxiation. Use this product only in a well ventilated area.**

5. Avoid installing machines in small areas or near exhaust fans. Exhaust contains poisonous carbon monoxide gas; exposure may cause loss of consciousness and may lead to death. It also contains

chemicals known, in certain quantities, to cause cancer, birth defects or other reproductive harm.

**WARNING**



**RISK OF FIRE. DO NOT ADD FUEL WHEN OPERATING MACHINE.**

**WARNING: Risk of fire. Do not add fuel when the product is operating.**

**WARNING: Risk of explosion — do not spray flammable liquids.**

6. Do not place machine near flammable objects as the engine is hot.

**WARNING: This product contains chemicals known to the state of California to cause cancer and birth defects or other reproductive harm. Operation of this equipment may create sparks that can start fires around dry vegetation. A spark arrestor may be required. The operator should contact: Local fire agencies for laws or regulations relating to fire prevention requirements.**

7. Allow engine to cool for 1-2 minutes before refueling. If any fuel is spilled, make sure the area is dry before testing the spark plug or starting the engine. (Fire and/or explosion may occur if this is not done.)

Gasoline engines on mobile or portable equipment shall be refueled:

- a. outdoors;
- b. with the engine on the equipment stopped;
- c. with no source of ignition within 10 feet of the dispensing point; and
- d. with an allowance made for expansion of the fuel should the equipment be exposed to a higher ambient temperature.

In an overfilling situation, additional precautions are necessary to ensure that the situation is handled in a safe manner.

**WARNING: Risk of injury. Disconnect battery ground terminal before servicing.**

8. Transport/repair with fuel tank EMPTY or with fuel shut-off valve OFF.

## IMPORTANT SAFETY INFORMATION

**WARNING**



KEEP WATER SPRAY AWAY FROM ELECTRICAL WIRING.

**WARNING:** Keep wand, hose, and water spray away from electric wiring or fatal electric shock may result.

9. Do not spray water on or near electrical components.

**WARNING**



RISK OF INJECTION OR SEVERE INJURY TO PERSONS. KEEP CLEAR OF NOZZLE.

**WARNING:** High pressure developed by these machines will cause personal injury or equipment damage. Keep clear of nozzle. Use caution when operating. Do not direct discharge stream at people, or severe injury or death will result.

**WARNING**



RISK OF EXPLOSION: DO NOT SPRAY FLAMMABLE LIQUIDS.

**WARNING:** Flammable liquids can create fumes which can ignite, causing property damage or severe injury.

**WARNING:** Risk of explosion — Do not spray flammable liquids.

10. Keep operating area clear of all persons.

- 13. Never make adjustments on machine while in operation.
- 14. Be certain all quick coupler fittings are secured before using pressure washer.

**WARNING**



EAR PROTECTION MUST BE WORN

**WARNING:** This machine exceeds 85 db appropriate ear protection must be worn.

**WARNING**



PROTECT FROM FREEZING

**WARNING:** Protect machine from freezing.

15. To keep machine in best operating conditions, it is important you protect machine from freezing. Failure to protect machine from freezing could cause malfunction of the machine and result in death,

serious bodily injury, and/or property damage. Follow storage instructions specified in this manual.

16. The best insurance against an accident is precaution and knowledge of the machine.

**WARNING**



USE PROTECTIVE EYE WEAR AND CLOTHING WHEN OPERATING THIS EQUIPMENT.

**WARNING:** High pressure spray can cause paint chips or other particles to become airborne and fly at high speeds. To avoid personal injury, eye, hand and foot safety devices must be worn.

11. Eye, hand, and foot protection must be worn when using this equipment.

**WARNING**



RISK OF INJURY FROM FALLS WHEN USING LADDER.

**WARNING:** Be extremely careful when using a ladder, scaffolding or any other relatively unstable location. The cleaning area should have adequate slopes and drainage to reduce the possibility of a fall due to slippery surfaces.

**WARNING**



TRIGGER GUN KICKS BACK - HOLD WITH BOTH HANDS

**WARNING:** Grip cleaning wand securely with both hands before starting. Failure to do this could result in injury from a whipping wand.

12. To reduce the risk of injury, close supervision is necessary when a machine is used near children. Do not allow children

- 17. Do not overreach or stand on unstable support. Keep good footing and balance at all times.
- 18. Do not operate this machine when fatigued or under the influence of alcohol, prescription medications, or drugs.
- 19. Inlet water must be clean fresh water and no hotter than 90°F.
- 20. Manufacturer will not be liable for any changes made to our standard machines or any components not purchased from us.
- 21. Do not allow acids, caustic or abrasive fluids to pass through the pump.
- 22. Never run pump dry or leave spray gun closed longer than 1-2 minutes.

to operate the pressure washer. **This machine must be attended during operation.**



**Follow the maintenance instructions specified in the manual.**

## COMPONENT IDENTIFICATION

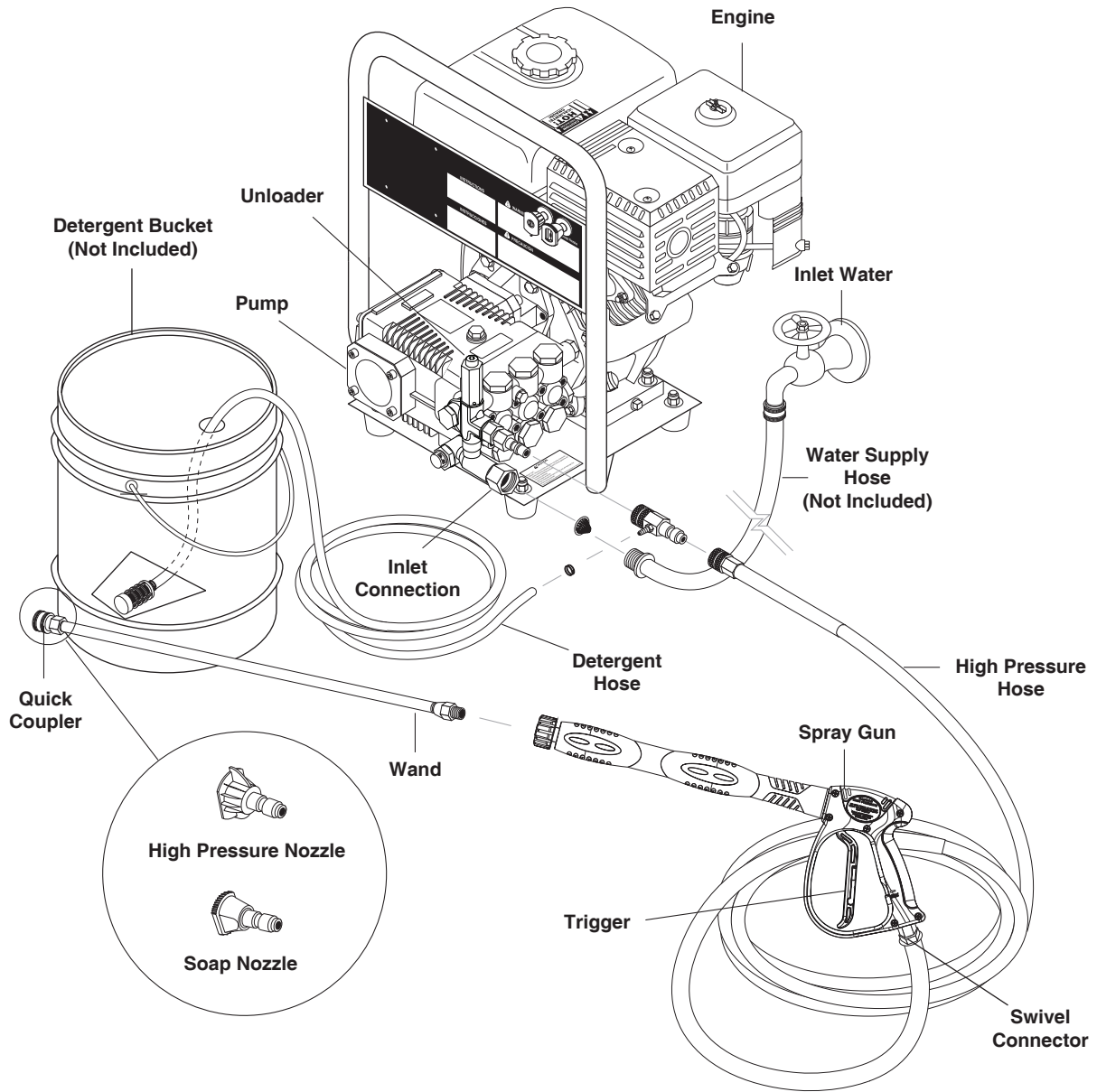

**Detergent Injector** - Allows you to siphon and mix detergents.

**High Pressure Hose** — Connect one end to water pump discharge nipple and the other end to spray gun.

**Nozzle Quick Coupler** -

**Pump** — Develops high pressure.

**Starter Grip** — Used for starting the engine manually.

**Spray Gun** — Controls the application of water and detergent onto cleaning surface with trigger device. Includes safety latch.

**Straight Through Wand** — Must be connected to the spray gun.

**Swivel Connector** - Allows free range of movement to avoid coiling hoses.

**Note:** If trigger on spray gun is released for more than 2 minutes, water will leak from valve. Warm water will discharge from pump protector onto floor. This system prevents internal pump damage.

# ASSEMBLY INSTRUCTIONS

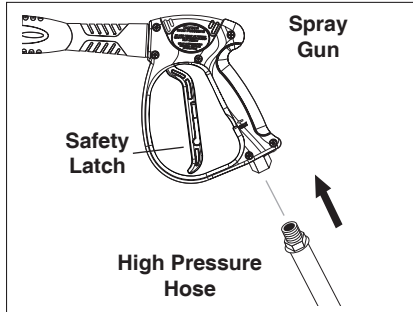

**STEP 1:** Attach the high pressure hose to the spray gun using teflon tape on hose threads.

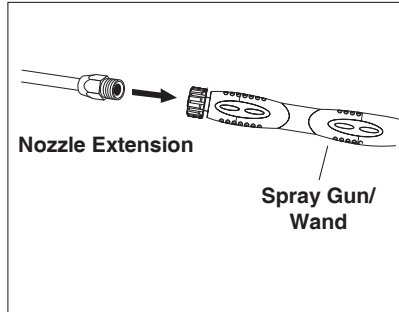

**STEP 2:** Attach nozzle extension to spray gun/wand. Tighten both by hand.

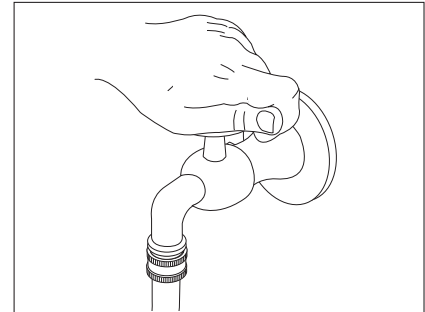

**STEP 3:** Before installing nozzle, turn on water supply and run machine allowing water to flush through the system until clear.

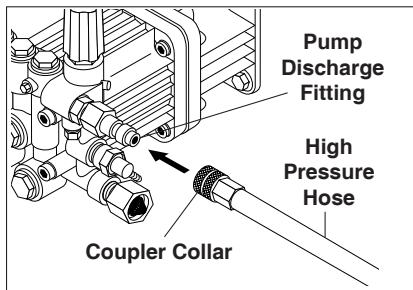

**STEP 4:** Connect the high pressure hose to the pump discharge fitting. Push coupler collar forward until secure.

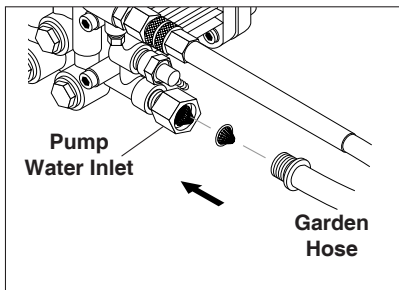

**STEP 5:** Connect the garden hose to pump water inlet. Inspect inlets. **CAUTION: Do not run the pump without water or pump damage will result.**

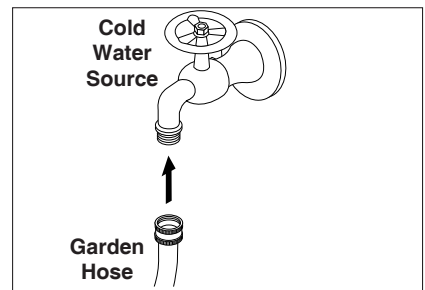

**STEP 6:** Connect garden hose to the cold water source.

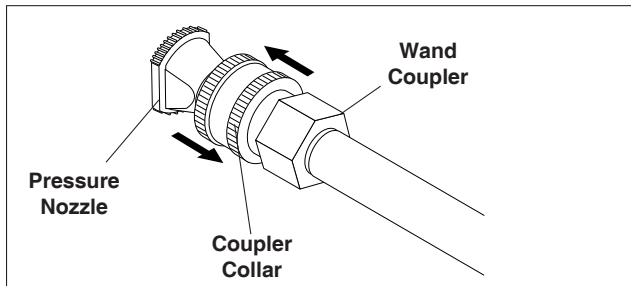

**STEP 7:** Pull the spring-loaded collar of the wand coupler back to insert your choice of pressure nozzle. Release the coupler collar and push the nozzle until the collar clicks. Pull the nozzle to make sure it is seated properly.

## OPERATING INSTRUCTIONS

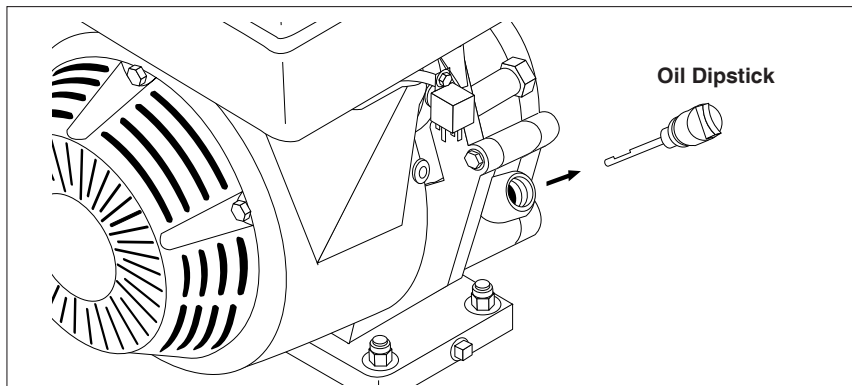

**STEP 1:** Check engine oil level. Oil level should be level with the bottom of the oil filler neck. Be sure the machine is level when checking the oil level. (Refer to the engine's operating manual included with machine.) We recommend that the oil be changed after the first 5 hours of use, then once every 50 hours. **Note:** Improper oil levels will cause low oil sensor to shut off engine. **IMPORTANT! Do not run engine with high or low oil levels as this will cause engine damage.**

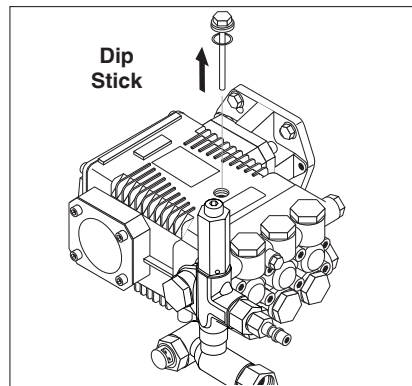

**STEP 2:** Remove shipping cap and install oil dipstick. Check pump oil level by using dipstick or observe oil level in oil window (if equipped). Use 30 wt. non detergent oil.

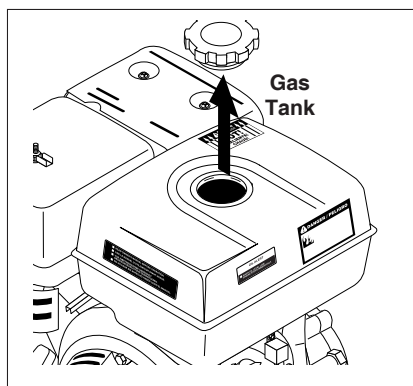

**STEP 3:** Fill gas tank with unleaded gasoline. Do not use leaded gasoline.

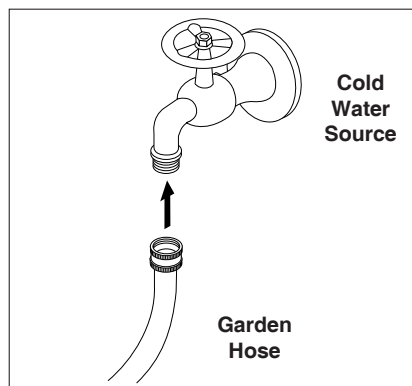

**STEP 4:** Connect garden hose to the cold water source and turn water on completely. Never use hot water.

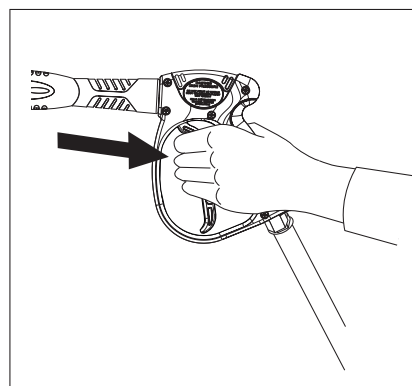

**STEP 5:** Trigger the spray gun to eliminate trapped air then wait for a steady flow of water to emerge from the spray wand. Then install nozzle.

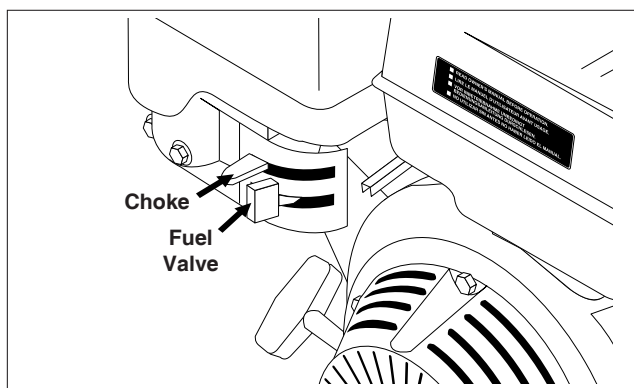

**STEP 6:** Rotate the fuel shut-off valve to the "On" position (fully counterclockwise on Briggs engines). Slide the fuel valve lever to the "ON" position (Honda engines). When the engine is not in use, leave the fuel valve in the "OFF" position.

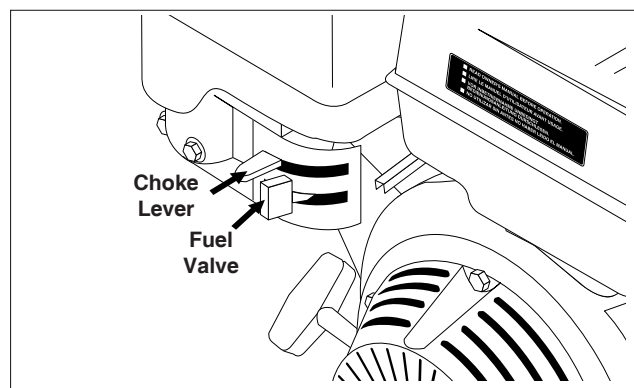

**STEP 7:** Move the choke lever to the "Choke" position (on a warm engine, leave the choke lever in the run position). On Honda engines, move the choke lever to the "Closed" position. To restart a warm engine, leave the choke lever in the "Open" position.



# OPERATING INSTRUCTIONS

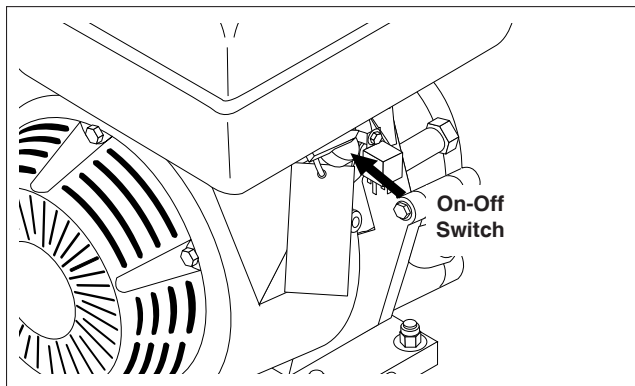

**STEP 8:** On Honda engines, turn the engine switch to "On" position.

On Briggs engines, move the throttle lever to "Fast" position, shown on engine as a rabbit.

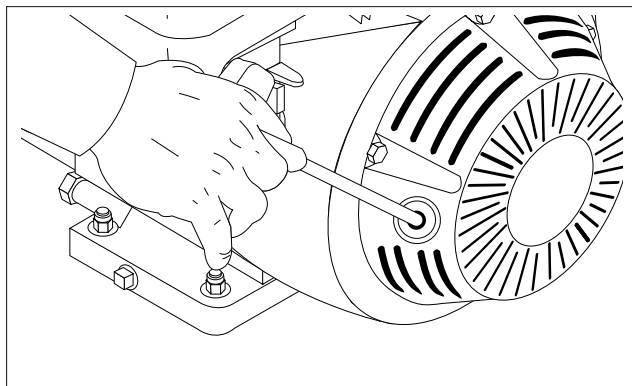

**STEP 9:** Pull the starter grip. If the engine fails to start after 2 pulls, squeeze the trigger gun to release pressure and repeat step. Return starter gently. After the engine warms up enough to run smoothly, move choke to run position and throttle to fast position.

**CAUTION:** Small engines may kick back. Do not hold pull starter grip tightly in hand.

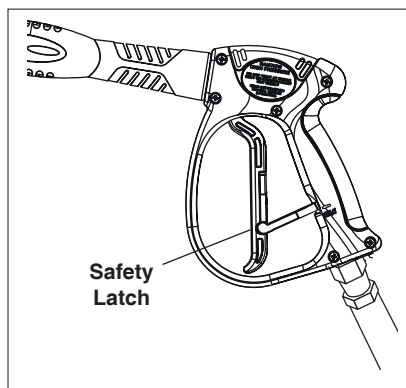

**WARNING!** Never replace nozzles without engaging the safety latch on the spray gun trigger.

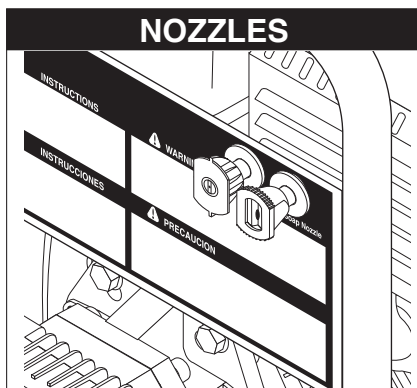

The two color-coded quick connect nozzles are easily accessible when placed in the convenient rubber nozzle holder, which is provided on the front of the machine.

**NOTE:** To rinse, select the yellow. To apply detergent select the black nozzle.

## DETERGENTS AND GENERAL OPERATING TECHNIQUES

### WARNING



**WARNING:** Some detergents may be harmful if inhaled or ingested, causing severe nausea, fainting or poisoning. The harmful elements may cause property damage or severe injury.

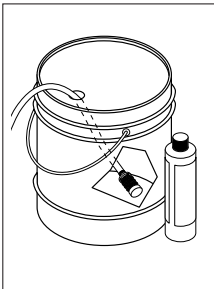

**STEP 1:** Use detergent designed specifically for pressure washers. Household detergents could damage the pump. Prepare detergent solution as required by the manufacturer. Fill a container with pressure washer detergent. Place the filter end of detergent suction tube into the detergent container.

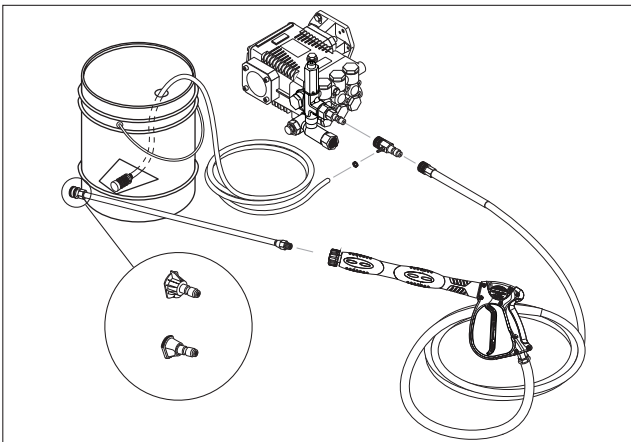

**STEP 2:** With safety latch on spray gun engaged, secure black detergent nozzle into quick coupler. **NOTE:** Detergent cannot be applied using the yellow nozzle.

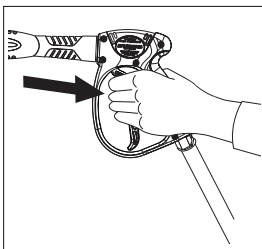

**STEP 3:** With the engine running, pull trigger to operate machine. Liquid detergent is drawn into the machine and mixed with water. Apply detergent to work area. Do not allow detergent to dry on surface.

**IMPORTANT:** You must flush the detergent injection system after each use by placing the suction tube into a bucket of clean water, then run the pressure washer in low pressure for 1-2 minutes.

### THERMAL PUMP PROTECTION

If you run the engine on your pressure washer for 3-5 minutes without pressing the trigger on the spray gun, circulating water in the pump can reach high temperatures. When the water reaches this temperature, the

pump protector engages and cools the pump by discharging the warm water onto the ground. This thermal device prevents internal damage to the pump.

### CLEANING TIPS

Pre-rinse cleaning surface with fresh water. Place detergent suction tube directly into cleaning solution and apply to surface at low pressure (for best results, limit your work area to sections approximately 6 feet square and always apply detergent from bottom to top). Allow detergent to remain on surface 1-3 minutes. Do not allow detergent to dry on surface. If surface appears to be drying, simply wet down surface with fresh water. If needed, use brush to remove stubborn dirt. Rinse at high pressure from top to bottom in an even sweeping motion keeping the spray nozzle approximately 1 foot from cleaning surface. Use overlapping strokes as you clean and rinse any surface. For best surface cleaning action spray at a slight angle.

### Recommendations:

- Before cleaning any surface, an inconspicuous area should be cleaned to test spray pattern and distance for maximum cleaning results.
- If painted surfaces are peeling or chipping, use extreme caution as pressure washer may remove the loose paint from the surface.
- Keep the spray nozzle a safe distance from the surface you plan to clean. High pressure wash a small area, then check the surface for damage. If no damage is found, continue to pressure washing.



### CAUTION - Never use:

- Bleach, chlorine products and other corrosive chemicals
- Liquids containing solvents (i.e., paint thinner, gasoline, oils)
- Tri-sodium phosphate products
- Ammonia products
- Acid-based products

These chemicals will harm the machine and will damage the surface being cleaned.

### RINSING

It will take a few seconds for the detergent to clear. Apply safety latch to spray gun. Remove black soap nozzle from the quick coupler. Select and install the desired high pressure nozzle. **NOTE:** You can also stop detergent from flowing by simply removing detergent siphon tube from bottle.

## SHUTTING DOWN AND CLEAN-UP

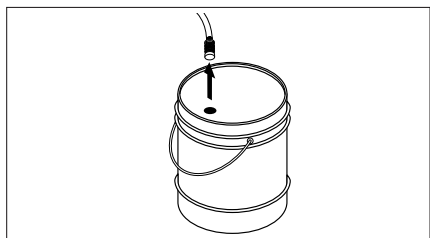

**STEP 1:** Remove detergent suction tube from container and insert into one gallon of fresh water. Slide nozzle forward for low pressure or to connect black detergent nozzle. Pull trigger on spray gun and siphon water for one minute.

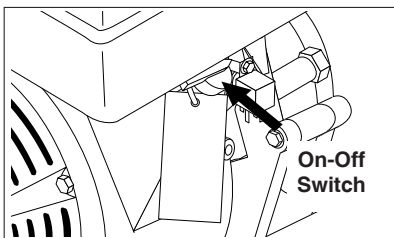

**STEP 2:** Move the throttle to stop the engine (Briggs Engine). Turn off the engine (Honda engines).

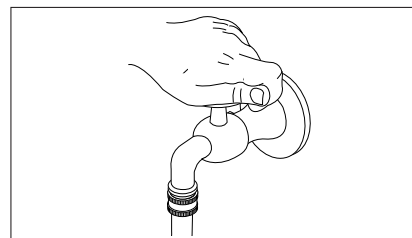

**STEP 3:** Turn off water supply.

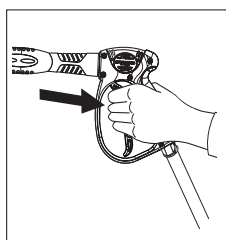

**STEP 4:** Press trigger to release water pressure.

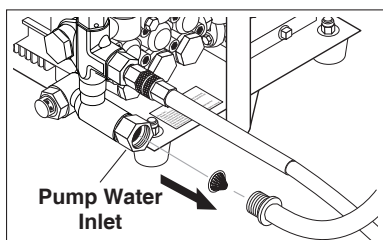

**STEP 5:** Disconnect the garden hose from the water inlet on the machine.

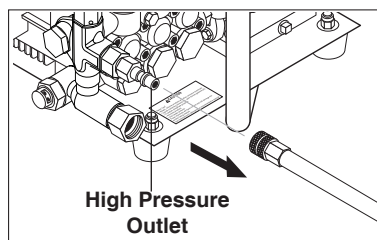

**STEP 6:** Disconnect the high pressure hose from high pressure outlet.

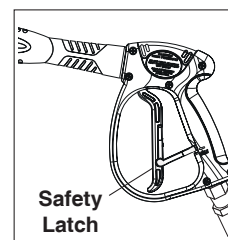

**STEP 7:** Engage spray gun safety lock.

## STORAGE

**CAUTION:** Always store your pressure washer in a location where the temperature will not fall below 32°F (0°C). The pump in this machine is susceptible to permanent damage if frozen. **FREEZE DAMAGE IS NOT COVERED BY WARRANTY.**

1. Stop the pressure washer, squeeze spray gun trigger to release pressure.
2. Detach water supply hose and high pressure hose.
3. Turn on the machine for a few seconds, until remaining water exits. Turn engine off immediately.
4. Drain the gas and oil from the engine.
5. Do not allow high pressure hose to become kinked.
6. Store the machine and accessories in a room which does not reach freezing temperatures.

**CAUTION:** Failure to follow the above directions will result in damage to your pressure washer.

When the pressure washer is not being operated or is being stored for more than one month, follow these instructions:

1. Replenish engine oil to upper level.
2. Drain gasoline from fuel tank, fuel line, fuel valve and carburetor.
3. Pour about one teaspoon of engine oil through the spark plug hole, pull the starter grip several times and replace the plug. Then pull the starter grip

slowly until you feel increased pressure which indicates the piston is on its compression stroke and leave it in that position. This closes both the intake and exhaust valves to prevent rusting of cylinder.

4. Cover the pressure washer and store in a clean, dry place that is well ventilated away from open flame or sparks. **NOTE:** The use of a fuel additive, such as STA-BIL®, or an equivalent, will minimize the formulation of fuel deposits during shortage. Such additives may be added to the gasoline in the fuel tank of the engine, or to the gasoline in a storage container.

### After Extended Storage



**CAUTION:** Prior to restarting, thaw out any possible ice from pressure washer hoses, spray gun or wand.

### Engine Maintenance

During the winter months, rare atmospheric conditions may develop which will cause an icing condition in the carburetor. If this develops, the engine may run rough, lose power and may stall. This temporary condition can be overcome by deflecting some of the hot air from the engine over the carburetor area. **NOTE:** Refer to the engine manufacturer's manual for service and maintenance of the engine.

## TROUBLESHOOTING

PROBLEM	POSSIBLE CAUSE	SOLUTION
<b>LOW OPERATING PRESSURE</b>	Faulty pressure gauge	Install new gauge.
	Insufficient water supply	Use larger garden hose; clean filter washer at water inlet.
	Old, worn or incorrect spray nozzle	Match nozzle number to machine and/or replace with new nozzle.
	Plumbing or hose leak	Check plumbing system for leaks. Retape leaks with teflon tape.
	Faulty or misadjusted unloader valve (where applicable)	Adjust unloader for proper pressure. Install repair kit when needed. <b>Note:</b> Tampering with the factory setting may cause personal injury and/or property damage, and will void the manufacturer's warranty.
	Worn packing in pump	Install new packing kit.
	Fouled or dirty inlet or discharge valves in pump	Clean inlet and discharge valves.
	Worn inlet or discharge valves	Replace with valve kit.
	Slow engine RPM	Set engine speed per specifications (approximately 2800 RPM - 3400 RPM)
<b>FLUCTUATING PRESSURE</b>	Valves worn	Check and replace if necessary.
	Blockage in valve	Check and clean out if necessary.
	Pump sucking air	Check water supply and suction line for air seepage at joints.
	Worn piston packing	Check and replace if necessary.
<b>PRESSURE LOW AFTER PERIOD OF NORMAL USE</b>	Nozzle worn	Check and replace if necessary.
	Inlet or discharge valves blocked or worn	Check and clean or replace if necessary.
	Unloader valve seat worn	Check and replace if necessary.
<b>PUMP NOISE</b>	Air suction line	Check water supply and connections on suction line.
	Broken or weak inlet or discharge valve springs	Check and replace if necessary.
	Foreign matter in valves	Check and clean if necessary.
	Worn bearings	Check and replace if necessary.
	Excessive temperature of liquid	Reduce to below 180°F (75°C)

## TROUBLESHOOTING

PROBLEM	POSSIBLE CAUSE	SOLUTION
<b>PRESENCE OF WATER IN PUMP OIL (2400 PSI MODELS ONLY)</b>	Water sprayed at machine	Change oil. Direct spray away from machine.
	High humidity in air	Check and change oil twice as often.
	Piston packing worn. Oil seal worn	Check and replace if necessary.
<b>ENGINE STRAINS UNDER LOAD</b>	Engine governor misadjusted	Readjust governor on engine. Take to local engine representative for adjustment.
	Incorrect spray nozzle	Install proper nozzle size (See serial plate for proper size).
	Obstruction in spray nozzle	Remove obstruction.
	Misadjusted unloader valve	Contact local dealer or technical support.
	Engine low or out of oil	Check oil level.
	Pump low or out of oil	Check oil level.
	Obstruction in hose, fitting	Clean or replace hose, fitting.
	Gasoline engine altitude	The gasoline engine is preset for operation at altitudes below 1000 feet above sea level. If operated at higher altitudes, it may be necessary to install a high altitude main jet carburetor. Contact your local authorized engine sales and service center for details.
<b>OIL SQUIRTS OUT OF OIL CAP ON PUMP</b>	Pump overfilled with oil	Maintain oil level at red dot on sight glass at rear of pump or at top of notch on dipstick (where applicable).
<b>ENGINE OPERATES FOR 15 MINUTES THEN STOPS</b>	Not enough gas or engine oil	Fill tank with gas. Check oil level.
	Vapor lock developed by heat of day	Keep gas tank full to avoid vapor lock.
	Obstruction in fuel filter	Clean or replace fuel filter.
<b>WATER DRIPPING FROM UNDER PUMP</b>	Piston packing worn	Check and replace if necessary.
	O-ring plunger retainer worn	Check and replace if necessary.
	Cracked piston	Check and replace if necessary.
<b>OIL DRIPPING</b>	Oil seal worn	Check and replace if necessary.
<b>EXCESSIVE VIBRATION IN DELIVERY LINE</b>	Irregular functioning of the valves	Check and replace if necessary.
<b>WATER LEAKING FROM PUMP PROTECTOR</b>	Spray gun closed with machine running 5 minutes or longer.	Open spray gun or turn off machine.
	Excessive water supply pressure	Place a pressure regulator at end of 50' garden hose.

## PREVENTATIVE MAINTENANCE

This pressure washer was produced with the best available materials and quality craftsmanship. However, you as the owner have certain responsibilities for the correct care of the equipment. Attention to regular preventative maintenance procedures will assist in preserving the performance of your equipment. Contact your dealer for maintenance. Regular preventative maintenance will add many hours to the life of your pressure washer. Perform maintenance more often under severe conditions.

MAINTENANCE SCHEDULE		
Engine Oil	Inspect	Every 8 hours or daily
	Change	Every 50 hours or monthly
Air Cleaner/Filter	Inspect	Every 8 hours or daily
	Change	Every 50 hours or monthly
Fuel Tank Filter		Every 100 hours or yearly
Spark Plug Maintenance		Every 100 hours or yearly
Check Valve Clearance		Yearly
Water Filter	Check	Every 8 hours or daily
	Clean	Yearly
Pump Oil	Inspect	Every 25 hours or weekly
	Change	Yearly

## OIL CHANGE RECORD

Check pump oil (2400 PSI Models Only) and engine oil level before first use of your new pressure washer.

Date Oil Changed Month/day/year	Estimated Operating Hours Since Last Oil Change	Date Oil Changed Month/day/year	Estimated Operating Hours Since Last Oil Change

# HOSE & SPRAY GUN ASSEMBLY

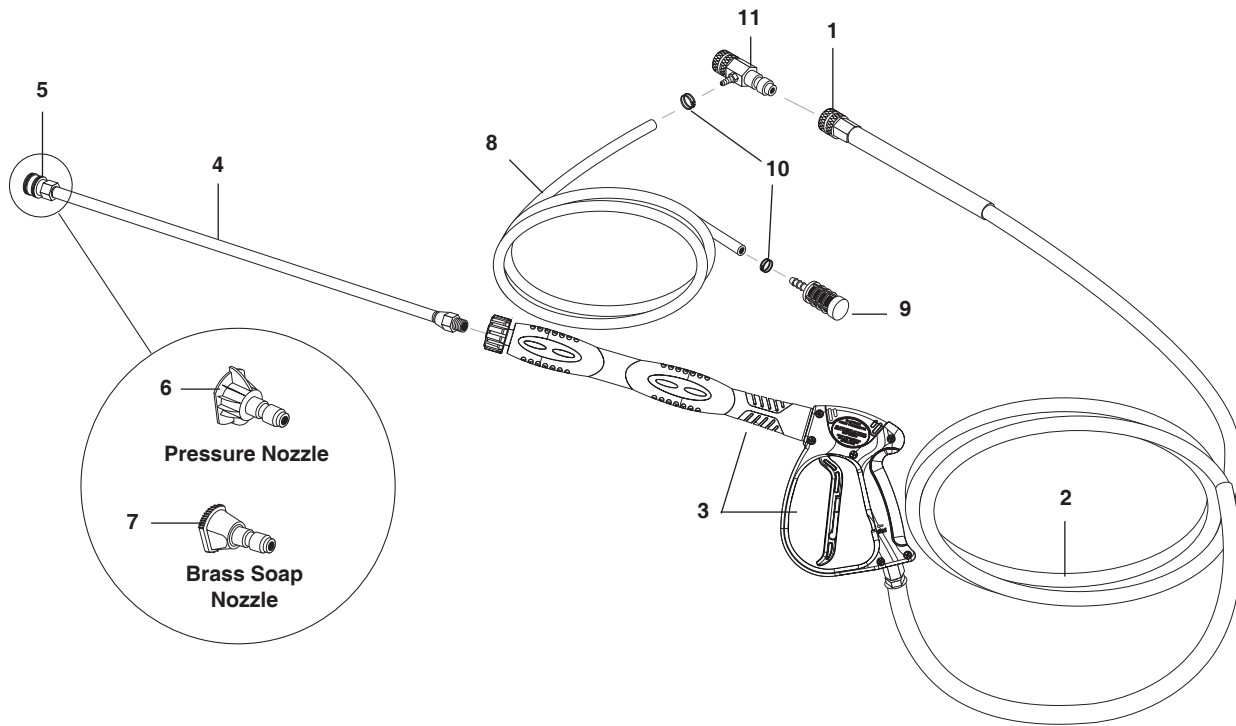

## HOSE & SPRAY GUN ASSEMBLY PARTS LIST

ITEM	PART NO.	DESCRIPTION	QTY	ITEM	PART NO.	DESCRIPTION	QTY
1	9.802-166.0	Coupler, 3/8" Female (2400 PSI)	1	7	8.712-398.0	Nozzle, Brass Soap	1
	9.802-100.0	▲ Quick Coupler O-Ring (2400 PSI)	1	8	9.802-251.0	Hose, 1/4" x 1/2" Clear Vinyl (2400 PSI)	6 ft.
	8.707-182.0	▲ Coupler, Twist Connect, M22-F x 3/8" FNPT (2300 PSI)	1		6.388-216.0	Hose DN5 (2300 PSI)	6 ft.
2	8.739-010.0	Hose, 3/8X25', 1w, Ts, Hotsy, So x Sw	1	9	8.707-057.0	Strainer, 1/4" Plastic (2400 PSI)	1
	8.739-020.0	Hose, 3/8X25', 1w, Ts, Karcher, So X Sw	1		5.731-652.0	Filter with weight (2300 PSI)	1
	8.739-025.0	Hose, 3/8X25', 1w, Ts, Landa, So X Sw	1	10	6.390-126.0	Clamp, Hose (2400 PSI)	2
3	8.754-769.0	Spray Gun, Shut-Off	1	11	9.802-216.0	Injector, Chem., Non-Adj, 3-5 GPM, .083 (2400 PSI)	1
4	9.112-533.0	Lance-AL Quick Connect-Male 3000 PSI	1			▲ Not Shown	
5	9.802-164.0	Coupler, 1/4" Female	1				
	9.802-096.0	Quick Coupler O-Ring	1				
6	8.712-333.0	Nozzle, 3.0 15° Yellow (2400 PSI)	1				
	8.753-991.0	Nozzle, 3.25 15° Yellow	1				



**HOTSY LIMITED NEW PRODUCT WARRANTY  
PRESSURE WASHERS  
WHAT THIS WARRANTY COVERS**

All Hotsy pressure washers are warranted by Hotsy to the original purchaser to be free from defects in materials and workmanship under normal use, for the periods specified below. This Limited Warranty is subject to the exclusions shown below, is calculated from the date of the original purchase, and applies to the original components only. Any parts replaced under this warranty will assume the remainder of the part's warranty period.

**SEVEN YEAR PARTS AND ONE YEAR LABOR WARRANTY:**

Components manufactured by Hotsy, such as frames, handles, top and bottom wraps, float tanks, fuel tanks, belt guards, and internal components on the oil-end of HOTSYS manufactured pumps. General, AR, Liberty, Comet and swash and wobble plate pumps have a one year warranty. Heating coils have a five year warranty from date of original machine purchase.

**ONE YEAR PARTS AND ONE YEAR LABOR WARRANTY:**

All other components, excluding normal wear items as described below, will be warranted for one year on parts and labor. Parts and labor warranty on these parts will be for one year regardless of the duration of the original component manufacturer's part warranty.

**WARRANTY PROVIDED BY OTHER MANUFACTURERS:**

Motors, generators, and engines, which are warranted by their respective manufacturers, are serviced through these manufacturers' local authorized service centers. Hotsy is not authorized and has no responsibility to provide warranty service for such components.

**WHAT THIS WARRANTY DOES NOT COVER**

This warranty does not cover the following items:

1. Normal wear items, such as nozzles, spray guns, discharge hoses, wands, quick couplers, seals, filters, gaskets, O-rings, packings, pistons, pump valve assemblies, strainers, belts, brushes, relief valves, fuses, pump protectors.
2. Damage or malfunctions resulting from accidents, abuse, modifications, alterations, incorrect installation, improper servicing, failure to follow manufacturer's maintenance instructions, or use of the equipment beyond its stated usage specifications as contained in the operator's manual.
3. Damage due to freezing, chemical deterioration, scale build up, rust, corrosion, or thermal expansion.
4. Damage to components from fluctuations in electrical or water supply.
5. Normal maintenance service, including adjustments, fuel system cleaning, and clearing of obstructions.
6. Transportation to service center, field labor charges, or freight damage.

**WHAT YOU MUST DO TO OBTAIN WARRANTY SERVICE**

In order to obtain warranty service on items warranted by Hotsy, you must return the product to your Authorized Hotsy Distributor, freight prepaid, with proof of purchase, within the applicable warranty period. If the product is permanently installed, you must notify your Authorized Hotsy Distributor of the defect. Your Authorized Hotsy Distributor will file a claim with Hotsy, who must subsequently verify the defect. In most cases, the part must be returned to Hotsy freight prepaid with the claim. For warranty service on components warranted by other manufacturer's, your Authorized Hotsy Distributor can help you obtain warranty service through these manufacturers' local authorized service centers.

**LIMITATION OF LIABILITY**

Hotsy's liability for special, incidental, or consequential damages is expressly disclaimed. In no event shall Hotsy's liability exceed the purchase price of the product in question. Hotsy makes every effort to ensure that all illustrations and specifications are correct, however, these do not imply a warranty that the product is merchantable or fit for a particular purpose, or that the product will actually conform to the illustrations and specifications. Our obligation under this warranty is expressly limited at our option to the replacement or repair at a service facility or factory designated by us, of such part or parts as inspection shall disclose to have been defective. **THE WARRANTY CONTAINED HEREIN IS IN LIEU OF ALL OTHER WARRANTIES, EXPRESS OR IMPLIED, INCLUDING ANY IMPLIED WARRANTY OF MERCHANTABILITY OR FITNESS FOR A PARTICULAR PURPOSE ARE EXPRESSLY LIMITED TO THE DURATION OF THIS WRITTEN WARRANTY.** Hotsy does not authorize any other party, including authorized Hotsy Distributors, to make any representation or promise on behalf of Hotsy, or to modify the terms, conditions, or limitations in any way. It is the buyer's responsibility to ensure that the installation and use of Hotsy products conforms to local codes. While Hotsy attempts to assure that its products meet national codes, it cannot be responsible for how the customer chooses to use or install the product. Some states do not allow limitations on how long an implied warranty lasts or the exclusion or limitation of incidental or consequential damages, so the above limitation or exclusion may not apply to you. This warranty gives you specific legal rights and you may also have other rights which vary from state to state.

**HOTSY**  
www.hotsy.com



If you need service on your pressure washer, contact your local Hotsy dealer or visit [www.Hotsy.com](http://www.Hotsy.com). Smart phone users scan the code below to link directly to the Service Request page.

