

**Hotsy CWC  
Stationary Cold Water Series  
OPERATOR'S MANUAL**

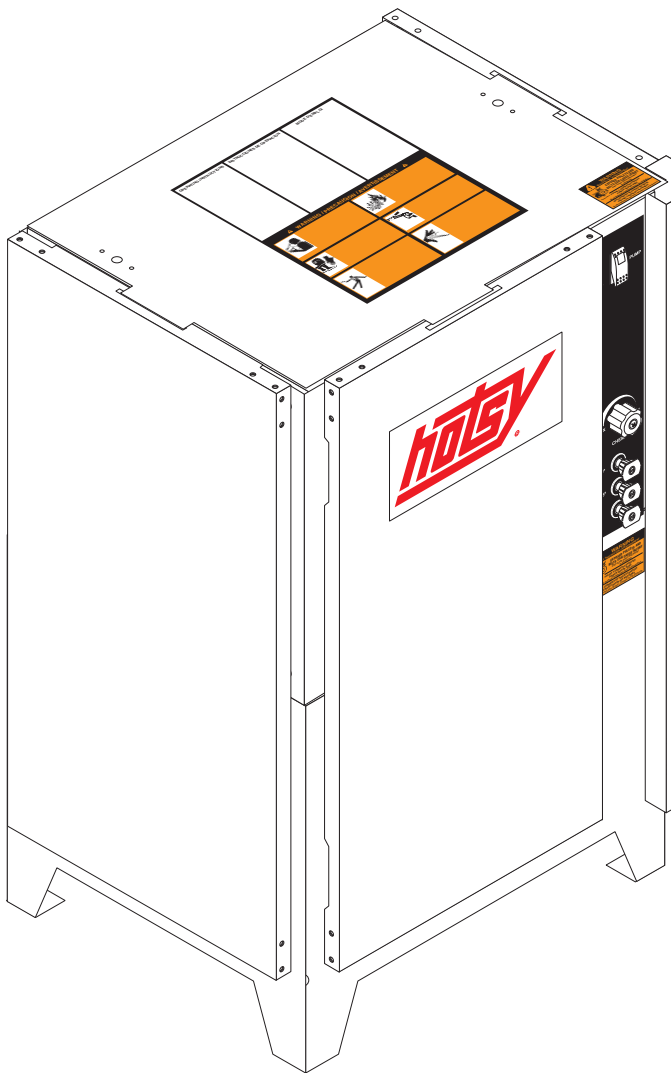

**Pressure Washer**

**MODELS:**



**CWC-53  
1.106-572.0**

**CWC-54  
1.106-573.0**

**CWC-55  
1.106-574.0**

**CWC-56  
1.106-575.0**

**CWC-63  
1.106-576.0**

**CWC-64  
1.106-577.0**

**CWC-65  
1.106-578.0**

**CWC-66  
1.106-579.0**

**SHOP PRESSURE WASHER PARTS**

shoppresurewasherparts.com | 888.269.0172



Intertek

9.801-695.0-B



01/19/17

*Machine Data Label*

---

Model: \_\_\_\_\_

Date of Purchase: \_\_\_\_\_

Serial Number: \_\_\_\_\_

Dealer: \_\_\_\_\_

Address: \_\_\_\_\_

Phone Number: \_\_\_\_\_

Sales Representative: \_\_\_\_\_

**Machine Data Label . . . . .2**  
**Table of Contents . . . . .3**  
**How To Use This Manual . . . . .4**

*Safety*

Introduction & Safety Information . . . . .5  
Important Safety Information. . . . .6  
Technical Specifications . . . . .8

*Operations*

Component Identification . . . . .9  
Assembly Instructions . . . . .10  
Operations Instructions . . . . .11

*Maintenance*

Pump . . . . .13  
Smart Relay Instructions . . . . .14  
Optional — Water Inlet Solenoid. . . . .17  
Troubleshooting . . . . .18

## How To Use This Manual

---

This manual contains the following sections:

- How to Use This Manual
- Safety
- Operations
- Maintenance

The HOW TO USE THIS MANUAL section will tell you how to find important information for ordering correct repair parts.

Parts may be ordered from authorized dealers. When placing an order for parts, the machine model and machine serial number are important. Refer to the MACHINE DATA box which is filled out during the installation of your machine. The MACHINE DATA box is located on the inside of the front cover of this manual.

Model: _____
Date of Purchase: _____
Serial Number: _____
Dealer: _____
Address: _____
Phone Number: _____
Sales Representative: _____

The model and serial number of your machine is located on the back of the machine.

The SAFETY section contains important information regarding hazardous or unsafe practices of the machine. Levels of hazards are identified that could result in product damage, personal injury, or severe injury resulting in death.

The OPERATIONS section is to familiarize the operator with the operation and function of the machine.

The MAINTENANCE section contains preventive maintenance to keep the machine and its components in good working condition. They are listed in this general order:

- Pump
- Smart Relay
- Optional Water Inlet
- Troubleshooting

*NOTE: If a service or option kit is installed on your machine, be sure to keep the KIT INSTRUCTIONS which came with the kit. It contains replacement parts numbers needed for ordering future parts.*

*NOTE: The manual part number is located on the lower right corner of the front cover.*

## Introduction & Safety Information

Thank you for purchasing this Pressure Washer.

We reserve the right to make changes at any time without incurring any obligation.

### Owner/User Responsibility:

The owner and/or user must have an understanding of the manufacturer's operating instructions and warnings before using this pressure washer. Warning information should be emphasized and understood. If the operator is not fluent in English, the manufacturer's instructions and warnings shall be read to and discussed with the operator in the operator's native language by the purchaser/owner, making sure that the operator comprehends its contents.

Owner and/or user must study and maintain for future reference the manufacturers' instructions.

The operator must know how to stop the machine quickly and understand the operation of all controls. Never permit anyone to operate the machine without proper instructions.

## SAVE THESE INSTRUCTIONS

**This manual should be considered a permanent part of the machine and should remain with it if machine is resold.**

**When ordering parts, please specify model and serial number. Use only identical replacement parts. This machine is to be used only by trained operators.**

## Identification Of Operational Label Symbols



**Pump Switch**



**Hour Meter**



**Detergent**

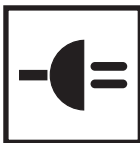

**Voltage**

When the light is on, it means power supply is on



**Motor Overload**

When the light is on, it means the overload is tripped.  
Reset overload.

*Not all machines have all symbols*

### Important Safety Information

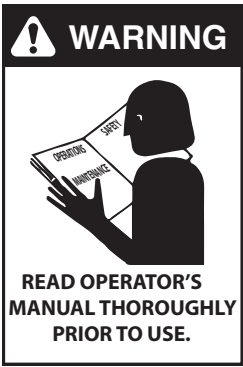

**WARNING:** To reduce the risk of injury, read operating instructions carefully before using.

1. Read the owner's manual thoroughly. Failure to follow instructions could cause malfunction of the machine and result in death, serious bodily injury and/or property damage.
2. Know how to stop the machine and bleed pressure quickly. Be thoroughly familiar with the controls.
3. Stay alert — watch what you are doing.
4. All installations must comply with local codes. Contact your electrician, plumber, utility company or the selling dealer for specific details.

**DANGER:** Improper connection of the equipment-grounding conductor can result in a risk of electrocution. Check with a qualified electrician or service personnel if you are in doubt as to whether the outlet is properly grounded. Do not modify the plug provided with the product - if it will not fit the outlet, have a proper outlet installed by a qualified electrician. Do not use any type of adaptor with this product



**WARNING:** Keep wand, hose, and water spray away from electric wiring or fatal electric shock may result.

5. To protect the operator from electrical shock, the machine must be electrically grounded. It is the responsibility of the owner to connect this machine to a UL grounded receptacle of proper voltage and amperage ratings. Do not

spray water on or near electrical components. Do not touch machine with wet hands or while standing in water. Always disconnect power before servicing.



**WARNING:** Flammable liquids can create fumes which can ignite, causing property damage or severe injury.

**WARNING:** Risk of explosion — Do not spray flammable liquids.

6. Do not allow acids, caustic or abrasive fluids to pass through the pump.
7. Never run pump dry or leave spray gun closed longer than 1-2 minutes.
8. Keep operating area clear of all persons.



**WARNING:** High pressure spray can cause paint chips or other particles to become airborne and fly at high speeds. To avoid personal injury, eye, hand and foot safety devices must be worn.

9. Always wear properly rated eye protection such as safety goggles or face shield while spraying. (Safety glasses do not provide full protection.)



**WARNING:** Grip cleaning wand securely with both hands before starting. Failure to do this could result in injury from a whipping wand.



**WARNING:** High pressure developed by these machines will cause personal injury or equipment damage. Keep clear of nozzle. Use caution when operating. Do not direct discharge stream at people, or severe injury or death will result.

- 10. To reduce the risk of injury, close supervision is necessary when a machine is used near children. Do not allow children to operate the pressure washer. **This machine must be attended during operation.**
- 11. Never make adjustments on machine while in operation.
- 12. Be certain all quick coupler fittings are secured before using pressure washer.



**WARNING: Protect machine from freezing.**

- 13. To keep machine in best operating conditions, it is important you protect machine from freezing. Failure to protect machine from freezing could cause malfunction of the machine and result in death, serious bodily injury, and/or property damage. Follow storage instructions specified in this manual.

- 14. Inlet water must be clean fresh water and no hotter than 90°F.
- 15. Manufacturer will not be liable for any changes made to our standard machines or any components not purchased from us.
- 16. The best insurance against an accident is precaution and knowledge of the machine.



**WARNING: Be extremely careful when using a ladder, scaffolding or any other relatively unstable location. The cleaning area should have adequate slopes and drainage to reduce the possibility of a fall due to slippery surfaces.**

- 17. Do not overreach or stand on unstable support. Keep good footing and balance at all times.
- 18. Do not operate this machine when fatigued or under the influence of alcohol, prescription medications, or drugs.



- 19. Follow the maintenance instructions specified in the manual.



**WARNING: Must be plugged into properly wired three hole grounded outlet that accommodates plug on power cored. Failure to comply could result in electrical shock.**

Technical Specifications

<b>Model #</b>	<b>Pump Volume @ Pump Head</b>	<b>Pump Pressure at Pump Head</b>	<b>Motor HP</b>	<b>Machine Voltage</b>	<b>Total Machine Amperage</b>	<b>Machine Weight</b>	<b>Shipping Weight</b>	<b>Machine Dimensions</b>
<b>CWC-53</b>	3.9 GPM / 234 GPH	3000 PSI	7.5	230VAC / 60Hz 1Ph	36 Amps	289 Lbs	340 Lbs	L 24.25" X W 21" X H 36"
<b>CWC-54</b>	3.9 GPM / 234 GPH	3000 PSI	7.5	230VAC / 60Hz 3Ph	23 Amps	289 Lbs	340 Lbs	L 24.25" X W 21" X H 36"
<b>CWC-55</b>	3.9 GPM / 234 GPH	3000 PSI	7.5	460VAC / 60Hz 3Ph	11 Amps	289 Lbs	340 Lbs	L 24.25" X W 21" X H 36"
<b>CWC-56</b>	3.9 GPM / 234 GPH	3000 PSI	7.5	575VAC / 60Hz 3Ph	9 Amps	289 Lbs	340 Lbs	L 24.25" X W 21" X H 36"
<b>CWC-63</b>	4.95 GPM / 297 GPH	2000 PSI	7.5	230VAC / 60Hz 1Ph	28 Amps	289 Lbs	340 Lbs	L 24.25" X W 21" X H 36"
<b>CWC-64</b>	4.95 GPM / 297 GPH	2000 PSI	7.5	230VAC / 60Hz 3Ph	18 Amps	289 Lbs	340 Lbs	L 24.25" X W 21" X H 36"
<b>CWC-65</b>	4.95 GPM / 297 GPH	2000 PSI	7.5	460VAC / 60Hz 3Ph	9 Amps	289 Lbs	340 Lbs	L 24.25" X W 21" X H 36"
<b>CWC-66</b>	4.95 GPM / 297 GPH	2000 PSI	7.5	575VAC / 60Hz 3Ph	8 Amps	289 Lbs	340 Lbs	L 24.25" X W 21" X H 36"



## Component Identification

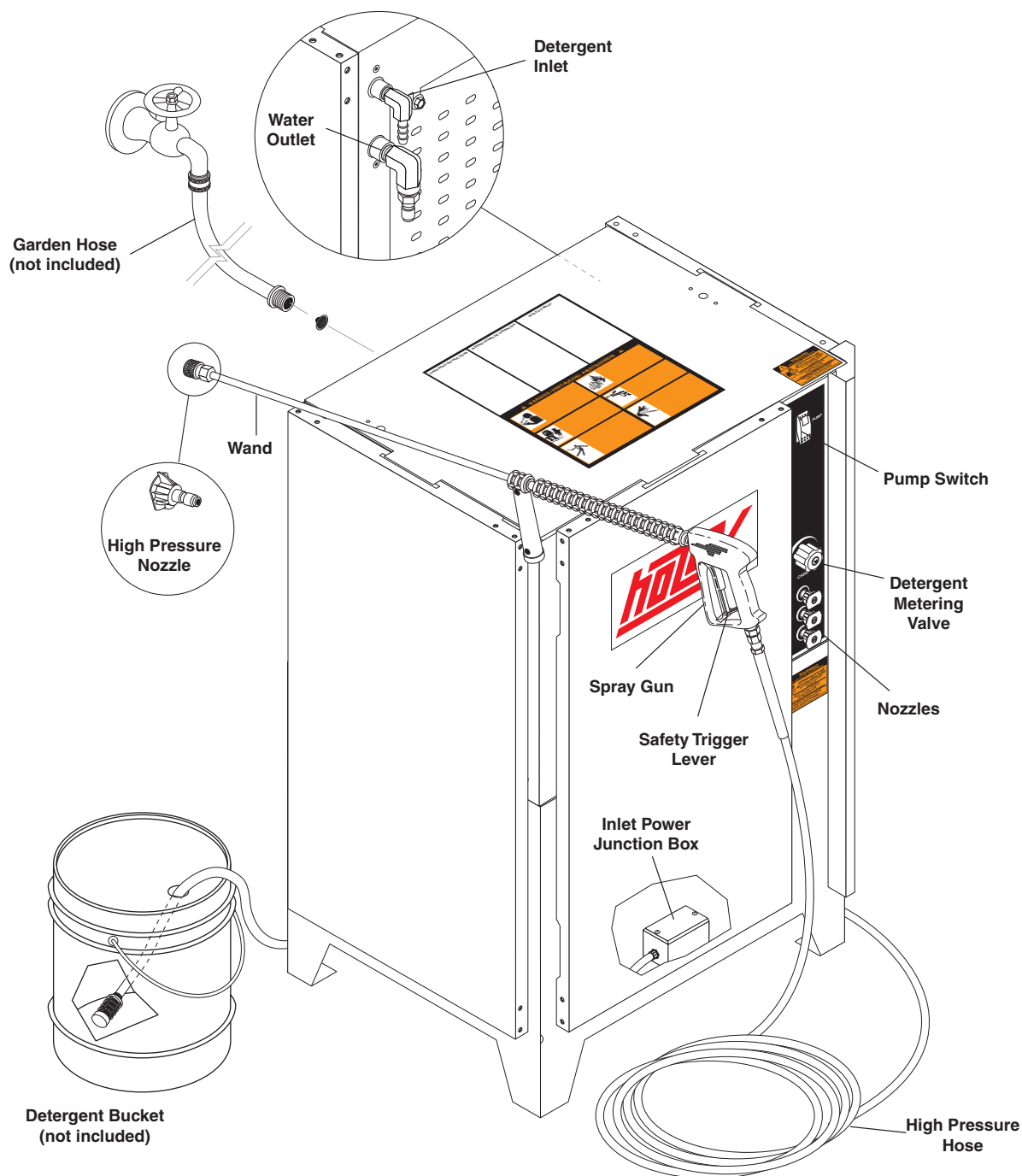

**Pump** — Develops high pressure by pumping water volume through nozzle.

**Spray Gun** — Controls the application of water and detergent onto cleaning surface with trigger device. Includes safety latch.

**Detergent Metering Valve** — Controls detergent mixture.

**Wand** — Must be connected to the spray gun.

**High Pressure Hose** — Connect one end to water pump discharge nipple and the other end to spray gun.

**Pressure Nozzle** — Inserted into wand quick coupler to develop pressure

**Safety Trigger Lever** — Prevents accidental triggering of spray gun while inserting a high pressure nozzle.

## Assembly Instructions

### Unpacking

Unpack carefully. Wear safety glasses or goggles while unpacking, assembling or operating pressure washer. If there are missing components or hidden damage immediately contact dealer or carrier concerning discrepancies.

1. Cut strapping band from pressure washer and pallet.
2. Remove pressure washer from pallet.

### Parts Included

- Pressure Washer
- Pressure Hose
- Wand
- Parts Box Containing:
  - Pressure Nozzles (3 on machine).
  - Trigger Gun
- Operating Instructions and Parts Manual

### Tools Required

- 10" Adjustable Crescent Wrenches (2 ea.) ?
- Blade Screwdriver

### Pressure Hose, Wand and Wand Holder

1. Use teflon tape on plumbing connections to prevent leakage.
2. Install pressure hose on machine as shown.
3. Assemble wand components as shown. Connect pressure hose to trigger gun.

**NOTE: The nozzle is not to be installed at this time.**

4. Make sure that all plumbing connections are tight.

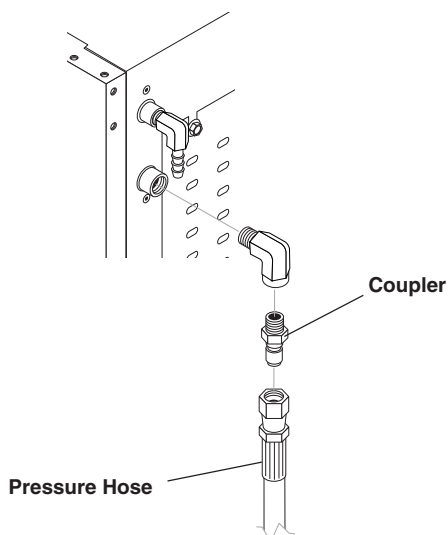
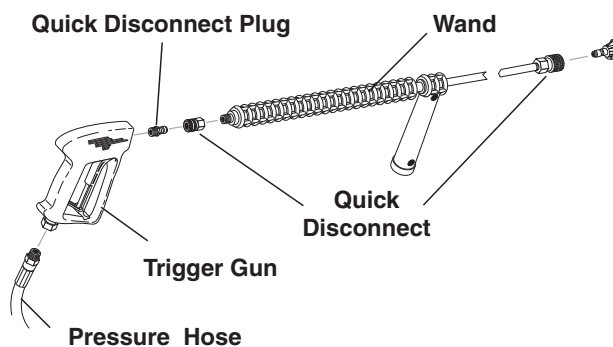

## Operations Instructions

### To Clean

**WARNING: Risk of injection or severe injury - Keep clear of nozzle - DO NOT direct discharge stream at persons - This machine is to be used only by qualified operators.**

**AVERTISSEMENT: RISQUE D'INJECTION ET DE BLESSURES GRAVES. SE TENIR À L'ÉCART DU JET. NE PAS DIRIGER LE JET DE SORTIE VERS D'AUTRES PERSONNES. CONFIER L'UTILISATION DE CE MATÉRIEL À UN OPÉRATEUR QUALIFIÉ.**

1. Insert detergent inlet line into container of mixed detergent. Open detergent ON/OFF valve. The detergent will be pulled automatically into the system. Allow detergent to reach end of wand before proceeding to step 3.
2. Select pressure nozzle with spray pattern that matches your cleaning needs. Engage manual trigger lock and install selected nozzle.
3. Wash from the bottom to the top, using side to side motions. This washes away heavy dirt and allows the detergent to soak as you work toward the top.
4. Do not wash at a 90° angle to the work (straight at it). This will allow water to splash back at you and reduces your cleaning power. Wash at a 30° to 60° angle to the work. This will allow the water to splash away from you and the water will wash the dirt away faster and easier.
5. Use the width of the spray pattern to wash in a wide path. Overlap spray paths for complete coverage. Wash from side to side, using slow, steady motions.
6. The nozzle should be 12" to 24" from work, closer for tough areas. Be careful on painted or delicate surfaces, the pressure may damage surface if nozzle is too close.
7. Small parts should be washed in a basket and larger, lightweight parts should be clamped down so the pressure does not push them away.
8. Close the detergent ON/OFF valve to permit rinse. Always rinse with cold water after using detergents. Rinse from the top to the bottom to prevent detergent from dripping onto a rinsed area. For the best results, contact your Hotsy dealer to help you select the best detergent for your application.

## Pre-Operation Check

- Read machine safety warnings
- Pump oil (SAE 10-40W (non-detergent oil))
- Cold water supply (1gpm over machines rating •5/8" • 20 psi)
- Proper power supply and circuit protection
- Hose, wand, nozzles (nozzle sizes per serial plate)
- Water filter (intact, non restrictive)
- Read operation instructions
- This machine must be protected from the elements/freezing.

## Set-Up Procedures

**This machine is intended for indoor use. Machine must be stored indoors when not in use.**

1. Attach a minimum 5/8" garden hose to inlet connector. Minimum flow should be 1 gpm over the flow rate of the pressure washer.
2. Attach high pressure hose to discharge nipple using quick coupler. Lock coupler securely into place by pulling back coupler collar and inserting it onto discharge nipple, then pushing collar forward to lock in place.
3. Attach wand to spray gun using teflon tape on threads to prevent leakage.
4. Attach connector on discharge hose to spray gun using teflon tape on threads.
5. Remove oil plug on top of pressure washer pump and replace with dipstick supplied. (This may be installed from the factory.)
6. Check oil level on oil dipstick on top of pump. Oil should be visible one half way up sight glass (10W-40 non-detergent).

## Operating Instructions

1. Read safety and preventative maintenance instructions before starting machine.
2. Turn on water at faucet and pull trigger on spray gun allowing water to flow until all air has discharged from system. Check for water leaks; tighten as needed.
3. Push the pump switch on.
4. Turn the variable pressure control handle clockwise to increase pressure.
5. To apply detergent read "How to Use The Detergent Injector."

## Shut Down-Up Procedures

1. Rinse with clean water to remove any soap residue, by placing detergent hose into fresh water bucket and operating injector as described below.
2. Release the trigger on the spray gun. Turn the switch off if the machine is going to be left unattended. (Time delay only).
3. Turn off water supply.
4. Open spray gun to relieve remaining pressure.
5. Remove water supply hose.

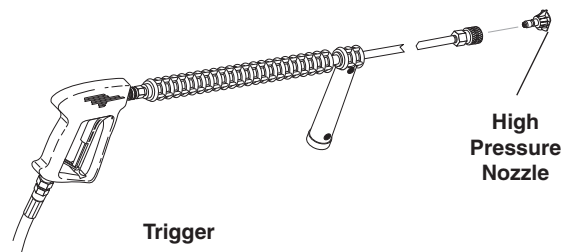

**IMPORTANT: The trigger gun provided with this pressure washer is equipped with a manual trigger lock to prevent accidental operation of the trigger gun, refer to figure above. The safety trigger lock should be used whenever the trigger gun is not in use.**

**WARNING: Unauthorized machine modification or use of non-approved replacement parts may cause personal injury and/or property damage and will void the manufacturer warranty.**

## Pump

Use Hotsy Pump Oil (8.914-527.0) for pump crankcase. Crankcase must be filled to the full mark on the dipstick or to center of sight glass window found on the rear of the pump. During the break-in-period, make sure the oil is changed after the first 25 hours of operation. After that, replace oil every 3 months or 300 hours of operation, whichever comes first.

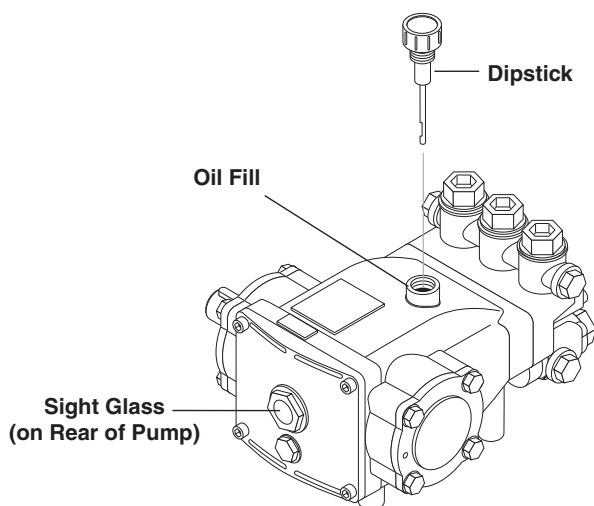

## Proper Pump Care:

- Do not pump acids.
- Do not allow pump to run dry.
- Winterize if storing in freezing temperatures; refer to **Storage** for details.
- Use a water softener on the water system if known to be high in mineral content.
- Use only high quality detergents and follow manufacturer's mix recommendations.
- Flush the system with clear water immediately after using detergent solutions.
- Clean filter screen on detergent inlet line periodically.
- Flush the pressure washer system with anti-freeze if storing for an extended period of time; refer to **Storage** for details.

## Pump Motor

On a yearly basis, oil pump motor per instructions on motor nameplate.

**NOTE: Some motors may be equipped with permanently lubricated bearings and will not require additional lubrication.**

## Unloader Valve

**WARNING: The unloader valve on this pressure washer has been factory set and sealed and is a field nonadjustable part. Tampering with the factory setting may cause personal injury and/or property damage, and will void the manufacturer warranty.**

## Smart Relay Instructions

### Digital Timer (Optional)

The following are instructions on how to set the parameters on the digital timer in Programming Mode. To define these settings please follow the steps below.

#### Setting the Clock:

1. Press the **ESC** key located next to the display window and under the arrow key pad (see figure below). Pressing the **ESC** key will access the Parameter Assignment Menu.

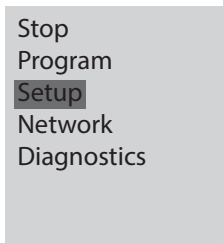
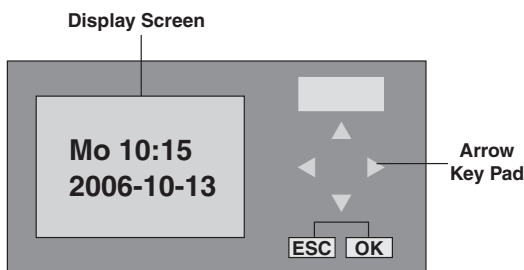

2. Using the up/down arrow keys ▲ or ▼, move the cursor to highlight 'Setup' and press OK to accept.

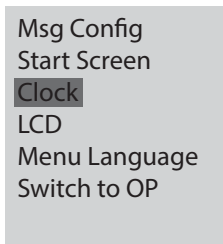

3. Move the cursor to highlight 'Clock' and press OK to accept.

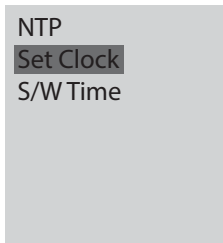

4. Move the cursor to highlight 'Set Clock' and press OK to accept.

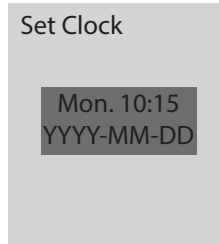

*NOTE: When setting time on clock, use only military time.*

5. Move the cursor to the value wanting to be changed using the left/right arrow keys ◀ or ▶, and change the value by using the up/down arrow keys ▲ or ▼. When you are done setting the time and date

press OK to accept your changes.

6. Press ESC three times to exit to the main menu.

### Programming Instructions

The CWC can be configured to run in Time Delay or Auto Start/Stop with lockout. Machines are factory set with Auto Start/Stop with 4 hour Lockout. A Smart Relay controls how the machine will operate by using three internal timers; these timers are adjustable. The following is a brief description of these timers:

#### Timer 1: 'Lockout Timer' (Time Delay)

- Timer 1 de-energizes (lockout) the machine if not being used for a preset time. If machine has 'Locked out' it can only be re-energize by pressing the 'Pump On' switch. Timer 1 is factory set to 4 hours.

#### Timer 2: 'Auto Start/Stop Timer'

- Timer 2 allows the pump to run in bypass for a preset time. If the pump runs in bypass longer than the allotted time the timer will drop power to the motor contactor and machine will be in standby mode. Squeezing the gun trigger will restart the pump (if Timer 1 has not locked out). Timer 2 is factory set to 30 seconds.

### Timer 3: 'Reset Delay Timer'

- Timer 3 controls how long the pump must run before resetting the 'Lockout Timer' (Timer 1). This allows the pump to run long enough to re-pressurize the system if there is pressure loss when not in use. Timer 3 is factory set to 15 seconds.

To change to the parameters of the internal timers in the Smart Relay complete the following steps:

1. Turn on the power to the machine but do not press the start switch. Remove the front panel and then the control panel cover. **NOTE: Use extreme CAUTION when reaching into the control box, the machine has live power.** Once powered the Smart Relay window will display the following screen, see figure 1 (if screen does not appear press the left/right arrow keys ◀ or ▶ until correct screen appears).

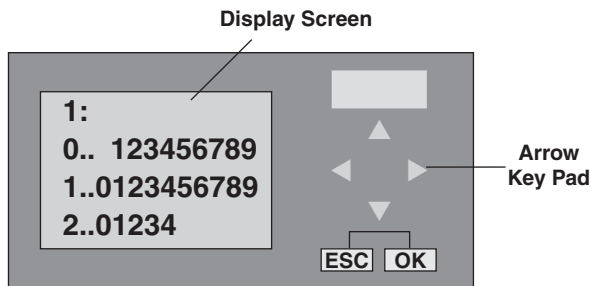
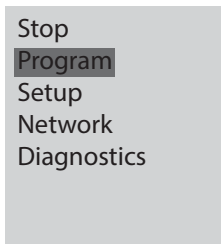
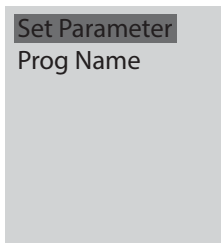

Fig. 1

2. Press the ESC key located next to the display window and under the arrow key pad to access the Menu.



3. Using the up/down arrow key s or t, move the cursor to highlight 'Program' and press OK to confirm.



4. Using the up/down arrow key s or t, move the cursor to highlight 'Set Parameter' and press OK to confirm.

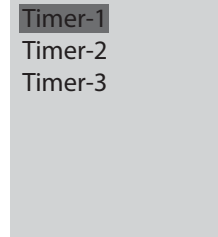

5. The display window will display the Timers. Highlight the Timer desired to change and press OK.

*NOTE: Ta is the accumulator timer and T is the adjustable timer (the variable that changes).*

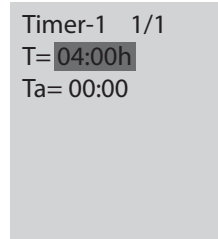

6. Highlight the T field and press OK to edit the value. Use the left/right arrow keys t or u, move the cursor to the used the up/down arrow keys s or t to change this value. Each timer has optional units of time in seconds (s), minutes (m), and hours (h). To change

the unit of time using the arrows up/down keys s or t. Once all values have been set press, OK to accept and ESC to back up to the Timer selection menu.

Repeat steps 5 and 6 for the other times if needed.

When finished press ESC three times to go to the main menu.

**Factory Set Parameters (Auto Start/Stop with Lockout)**

<b>TIMER</b>	<b>VALUE</b>	<b>DESCRIPTION</b>
Timer 1	04:00 Hours	Turns machine off after 4 hours of non-use. To restart push the 'Pump On' switch.
Timer 2	30:00 Seconds	Pump will run in bypass for 30 seconds before shutting off, machine is still in standby mode. Pulling the gun trigger will restart the pump.
Timer 3	15:00 Seconds	In case of pressure loss when machine is in standby, the pump can run up to 15 seconds before resetting 'Timer 1' (lockout)

**Time Delay Parameters**

<b>TIMER</b>	<b>VALUE</b>	<b>DESCRIPTION</b>
Timer 1	03:00 Minutes	When machine is not in use, pump will run in bypass for 3 minutes and shut off. To restart push the 'Pump On' switch.
Timer 2	01:00 Hours	To operate in time delay mode timer 2 must be deactivated. This is done by setting timer 2 to value greater than timer 1.
Timer 3	15:00 Seconds	Pump must run more than 15 seconds to reset timer 1.



### Optional — Water Inlet Solenoid

A water inlet solenoid can be added to the machine that will open only when the machine is running or in standby. The solenoid closes when the machine is off to prevent possible water overflow when unattended.

### Installation

- Connect a 24V/AC normally closed solenoid on the water inlet, contact local Hotsy dealer for solenoid options.
- Connect solenoid to the remote terminal using 16 ga minimum wire
- Wire solenoid to remote terminal according to figure below

Before powering up machine, fill float tank to prime the system.

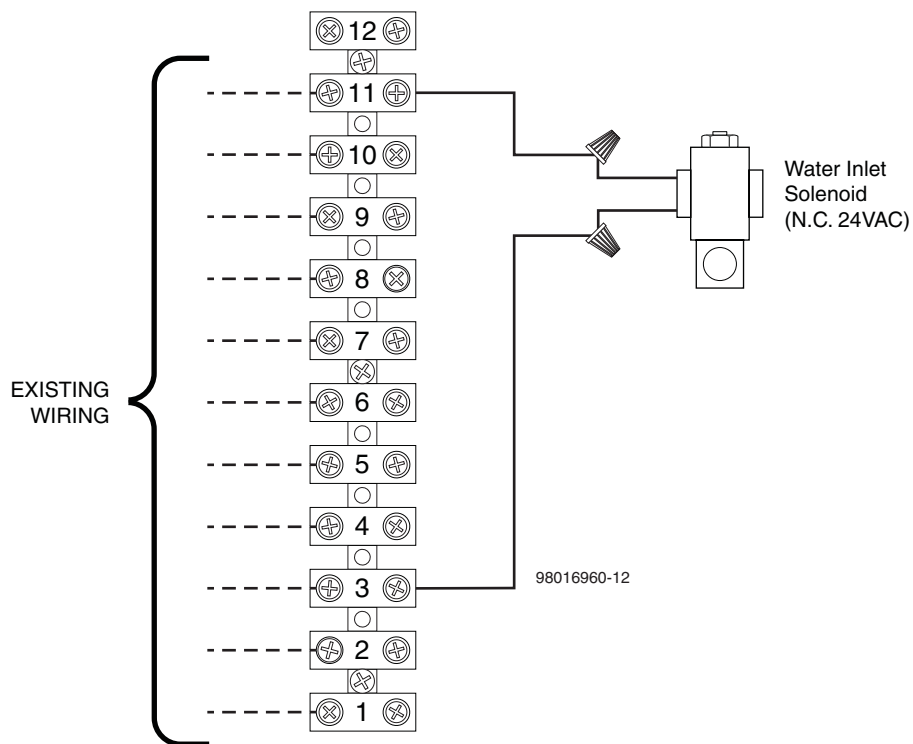

Water Inlet Solenoid Wiring Schematic  
(Remote Terminal Located Inside Machine)

### Water Inlet Solenoid Wiring Schematic

## Troubleshooting

PROBLEM	POSSIBLE CAUSE	SOLUTION
<b>LOW OPERATING PRESSURE</b>	Insufficient water supply	Fully open faucet. Use larger supply hose; clean filter at water inlet. Check for kinks.
	Old, worn or incorrect spray nozzle	Match nozzle number to machine and/or replace with new nozzle.
	Belt slippage	Tighten or replace; use correct belt.
	Plumbing or hose leak	Check plumbing system for leaks. Re-tape leaks with teflon tape.
	Faulty or mis-adjusted unloader valve (Where applicable)	Call local dealer. Tampering with the factory setting may cause personal injury and/ or property damage, and will void the manufacturer's warranty.
	Worn packing in pump	Install new packing kit.
	Fouled or dirty inlet or discharge valves in pump	Clean inlet and discharge valves.
	Worn inlet or discharge valves	Replace with valve kit.
	Obstruction in spray nozzle	Remove obstruction.
	Leaking pressure control valve (where applicable)	Rebuild or replace as needed.
	Insufficient power supply	Check voltage.
<b>FLUCTUATING PRESSURE</b>	Valves worn	Check and replace if necessary.
	Blockage in valve	Check and clean out if necessary.
	Pump sucking air	Check water supply and suction line for air seepage at joints.
	Worn piston packing	Check and replace if necessary.
<b>PRESSURE LOW AFTER PERIOD OF NORMAL USE</b>	Nozzle worn	Check and replace if necessary.
	Inlet or discharge valves worn	Check and replace if necessary.
	Inlet or discharge valves blocked	Check and clean if necessary.
	Unloader valve seat worn	Check and replace if necessary.
	Air being drawn through detergent inlet line	Refill the detergent container. Ensure that pick-up screen is fully immersed.
<b>PUMP NOISY</b>	Air in suction line	Check water supply and connections on suction line.
	Broken or weak inlet or discharge valve springs	Check and replace if necessary.
	Worn bearings	Check and clean if necessary.
	Worn bearings	Check and replace if necessary.
	Excessive temperature of liquid	Reduce to below 75° C (160°F).
<b>PRESENCE OF WATER IN PUMP OIL</b>	Oil seal worn	Check and replace if necessary.
	High humidity in air	Check and change oil twice as often.
	Piston packing worn	Check and replace if necessary.
<b>MOTOR STRAINS UNDER LOAD</b> (see next page)	Faulty motor	Send to nearest Baldor repair center.
	Incorrect spray nozzle	Install proper nozzle size (see serial plate for proper size).

<b>PROBLEM</b>	<b>POSSIBLE CAUSE</b>	<b>SOLUTION</b>
<b>MOTOR STRAINS UNDER LOAD (CONTINUED FROM PREVIOUS PAGE)</b>	Obstruction In Spray Nozzle	Remove Obstruction.
	Mis-adjusted Unloader Valve	Call Local Dealer.
	Pump Low Or Out Of Oil	Check Oil Level.
<b>OIL SQUIRTS OUT OF OIL CAP ON PUMP</b>	Pump Over Filled With Oil	Maintain Oil Level Halfway Up On The Sight Glass At Rear Of Pump Or At Top Of Notch On Dipstick (Where Applicable).
<b>PUMP RUNNING NORMALLY BUT PRESSURE OUTPUT LOW</b>	Pump Sucking Air	Check Water Supply And Possibility Of Air Seepage.
	Valves Sticking	Check And Clean Or Replace If Necessary.
	Unloader Valve Seat Faulty	Check And Replace If Necessary.
	Nozzle Incorrectly Sized	Check And Replace If Necessary (See Serial Plate For Proper Size).
	Worn Piston Packing	Check And Replace If Necessary.
<b>WATER DRIPPING FROM UNDER PUMP</b>	Piston Packing Worn	Check And Replace If Necessary.
	O-ring Plunger Retainer Worn	Check And Replace If Necessary.
	Cracked Piston	Check And Replace If Necessary.
<b>OIL DRIPPING</b>	Oil Seal Worn	Check And Replace If Necessary.
<b>EXCESSIVE VIBRATION IN DELIVERY LINE</b>	Irregular Functioning Of The Valves	Check And Replace If Necessary.
<b>SYSTEM WILL NOT START</b>	Motor Overload Tripped	Check And Reset.
	Pressure Switch Faulty (Time Delay Only)	Check, Clean Or Replace.
<b>MOTOR "HUMS" BUT DOES NOT TURN</b>	Electric Motor Single Phasing	Check For Blown Fuse Or Loose Power Line.
	Capacitor Bad 1ph	Have Motor Serviced.
<b>PRESSURE WASHER WILL NOT RUN</b>	Pump Switch In Off Position	Place Switch In On Position.
	Power Supply Disconnected	Connect Power Supply.
	Fuse Blown Or Circuit Breaker Tripped In Electrical Supply Line.	Replace Fuse Or Reset Circuit Breaker. Use Only Circuits Of Adequate Capacity.
	Motor Circuit Overload Tripped	Allow Sufficient Time For Motor To Cool Down. Place Pump Switch In On Position.
<b>PRESSURE WASHER RUNS BUT WONT SPRAY</b>	Trigger On Trigger Gun Released	Squeeze Trigger.
	Water Supply Not Turned On	Open Water Supply Valve.
	Clogged Pressure Nozzle	Clean Pressure Nozzle Opening.
	Inlet Water Screen Clogged	Check Screen And Clean If Necessary.
	Pump Sucking Air	Fill The Detergent Container And Check For Loose Hose Clamps Or Fittings.
<b>UNEVEN SPRAY PATTERN</b>	Partially clogged or damaged pressure nozzle	Clean or replace.

<b>PROBLEM</b>	<b>POSSIBLE CAUSE</b>	<b>SOLUTION</b>
<b>POOR OR NO DETERGENT FLOW</b>	Inadequate detergent supply	Refill the detergent container. Ensure that pick-up screen is fully immersed.
	Detergent screen or hose clogged	Clean. Always start with a clean detergent container.
	Clogged detergent injector check valve	Clean check valve at detergent injector.
<b>POOR CLEANING</b>	Improper detergent concentration or mixing	Mix detergent per manufacturer's instructions. Ensure that powdered detergents are fully dissolved.
	Wrong detergent for application	Select appropriate detergent.
	Detergent valve not opening	Check that handle or knob is not slipping on shaft.
<b>UNLOADER CYCLES WHEN TRIGGER GUN IS OPENED OR CLOSED</b>	Air in system	Open and close trigger gun several times.
	Unloader defective	Replace if defective.
	Water leak between unloader valve and trigger gun	Check fittings, hose and trigger gun for leaks. Repair or replace.

**IMPORTANT**

If the pressure washer demonstrates other symptoms or the corrective actions listed do not correct the problem, contact the local authorized Hotsy Service Center. The Hotsy Service Center can be identified by visiting [www.hotsy.com](http://www.hotsy.com).

**When ordering from your dealer, please provide the following:**

**Model Number:** \_\_\_\_\_ **Release:** \_\_\_\_\_

**Machine Serial Number:** \_\_\_\_\_

**Component Part Number:** \_\_\_\_\_

**Description:** \_\_\_\_\_

If you need **SERVICE** on your pressure washer, contact your local Hotsy dealer or visit [www.Hotsy.com](http://www.Hotsy.com). Smart phone users scan the code below to link directly to the Service Request page.



To **REGISTER** your pressure washer, please visit our Warranty Registration page at [www.hotsy.com/WarrantyRegistration.aspx](http://www.hotsy.com/WarrantyRegistration.aspx) or scan the code below with your smart phone.

